

iQpump Drive User Manual



◆ Quick Reference for iQpump (P7U) <0033>

Parameter Number	Factory Setting	User Setting	Parameter Number	Factory Setting	User Setting	Parameter Number	Factory Setting	User Setting	Parameter Number	Factory Setting	User Setting	Parameter Number	Factory Setting	User Setting
A1-00	0		C6-05	0		H4-04	8		n3-03	1.0		P2-12	15 RPM	
A1-01	2		d1-01	00145		H4-05	50.0%		n3-04	40 s		P2-13	5.0 s	
A1-03	0		d1-02	00145		H4-06	0.0%		o1-01	6		P2-14	5.0 s	
A1-04	0		d1-03	00145		H4-07	0		o1-02	1**		P2-15	0.0 (system units P1-02)	
A1-05	0		d1-04	00145		H4-08	0		o1-05	3		P2-16	1.5 (system units P1-02)	
b1-01	0		d1-17	0.00 to 6.00 Hz		H5-01	1F		o1-06	1**		P2-17	2.0 s	
b1-02	1		d2-01	100.0%		H5-02	3		o1-07	2**		P2-18	2.0 s	
b1-03	0		d2-02	0.0%		H5-03	0		o1-08	91**		P2-19	0	
b1-08	0		d2-03	0.0%		H5-04	3		o2-01	1**		P2-20	0.0 Hz	
b1-11	0 s		d3-01	0.0 Hz		H5-05	1		o2-02	1		P3-01	0	
b2-01	0.5 Hz		d3-02	0.0 Hz		H5-06	5 ms		o2-03	0		P3-02	59.0 Hz	
b2-02	50%		d3-03	0.0 Hz		H5-07	1		o2-05	kVA Dep.		P3-03	0.0 (system units P1-02)	
b2-03	0.00 s		d3-04	1.0 Hz		H5-09	2.0 s		o2-06	0		P3-04	59.0 Hz	
b2-04	0.50 s		E1-01	240.0 V 486.0 V		L1-01	1		o2-07	1		P3-05	0.0 (system units P1-02)	
b2-09	0%		E1-03	F		L1-02	8.0 min		o2-08	0 H		P3-06	5 s	
b3-01	2		E1-04	60.0 Hz		L1-03	3		o2-10	1		P3-07	0.0 (system units P1-02)	
b3-02	120%		E1-05	240.0 V 486.0 V		L1-04	1		o2-12	0		P3-08	0.0 (system units P1-02)	
b3-03	2.0 s		E1-06	60.0 Hz		L1-05	0.20 s		o2-14	0		P3-09	35.0 Hz	
b3-05	0.2 s		E1-07	3.0 Hz		L2-01	2		o3-01	0		P3-10	35.0 Hz	
b3-14	1		E1-08	17.2 Vac 33.6 Vac		L2-02	kVA Dep		o3-02	0		P3-11	2 s	
b4-01	0.0 s		E1-09	1.5 Hz		L2-03	kVA Dep		P1-01	0		P3-12	0.0 (system units P1-02)	
b4-02	0.0 s		E1-10	10.3 Vac		L2-04	kVA Dep		P1-02	1		P3-13	0.0 Hz	
b5-01	1		E1-11	0.0 Hz		L2-05	Voltage Class Dep.		P1-03	00145		P3-14	0.0 (system units P1-02)	
b5-02	2.00		E1-12	0.0 Vac		L3-01	1		P1-04	0.0 (system units P1-02)		P4-01	0.0 (system units P1-02)	
b5-03	5.0 s		E1-13	0.0 Vac		L3-02	120%		P1-05	0 s		P4-02	0.0 Hz	
b5-04	100.0%		E2-01	kVA Dep		L3-04	1		P1-06	35.0 Hz		P4-03	0.0 min	
b5-06	100.0%		E2-03	kVA Dep		L3-05	1		P1-07	0.0 (system units P1-02)		P4-04	2.0 s	
b5-07	0.0%		E2-04	2		L4-01	0.0 Hz		P1-08	5 s		P4-05	0.0 Hz	
b5-08	0.00 s		E2-05	kVA Dep		L4-02	2.0 Hz		P1-09	155.0 (system units P1-02)		P4-06	1.0 s	
b5-09	0		F6-01	1		L4-05	0		P1-10	2 s		P4-07	0	
b5-10	1.0		F6-02	0		L4-06	80%		P1-11	0.0 (system units P1-02)		P4-08	0	
b5-12	0		F6-03	1		L5-01	0		P1-12	60 s		P4-09	0.2 min	
b5-13	0%		F6-05	0		L5-02	0		P1-13	0.0 (system units P1-02)		P4-10	0	
b5-14	1.0 s		H1-01	24		L5-03	180.0 s		P1-14	0.0 A		P5-01	1	
b8-01	0		H1-02	14		L6-01	0		P1-15	0		P5-02	0.0 Hz	
b8-04	kVA Dep.		H1-03	3: 2 - Wire 0: 3 - Wire		L6-02	15%		P2-01	0		P5-03	1	
b8-05	2.0 ms		H1-04	80		L6-03	10.0 s		P2-02	0.0		P5-04	1	
b8-06	0%		H1-05	84		L8-01	0		P2-03	10 s		T1-02	kVA Dep.	
C1-01	25.0 s		H2-01	40		L8-02	95° C		P2-04	0.0 (system units P1-02)		T1-04	kVA Dep.	
C1-02	25.0 s		H2-02	41		L8-03	4		P2-05	10 s				
C1-03	10.0 s		H3-02	100.0%		L8-05	1		P2-06	0				
C1-04	10.0 s		H3-03	0.0%		L8-06	5.0%		P2-07	300 s				
C1-05	50.0 s		H3-08	2		L8-07	1		P2-08	0				
C1-06	50.0 s		H3-09	B*		L8-09	1		P2-09	0.0 (system units P1-02)				
C1-09	10.0 s		H3-10	100.0%		L8-10	0		P2-10	0.0 (system units P1-02)				
C1-11	0.0 Hz		H3-11	0.0%		L8-11	300 s		P2-11	0 RPM				
C2-01	0.20 s		H3-12	0.30 s		L8-12	45° C							
C2-02	0.20 s		H3-13	0		L8-15	1							
C4-01	1.00		H4-01	2		L8-18	1							
C4-02	200 ms		H4-02	100.0%		L8-19	20.0%							
C6-01	2		H4-03	0.0%		n1-01	1							
C6-02	kVA Dep					n1-02	1.00							
C6-03	kVA Dep					n3-01	5%							
C6-04	kVA Dep					n3-02	150%							

* Factory setting changes to "B" when b5-01=1.

** Factory setting changes to "B" when b5-01=1 as follows: o1-06=1, o1-07=38, o1-08=24

Table of Contents

Warnings and Cautions	7
Introduction	9
Physical Installation.....	11
iQpump Model Number and Enclosure Style	12
Confirmations Upon Delivery	13
Component Names	15
Exterior and Mounting Dimensions	17
Heat Loss Data	21
Checking and Controlling the Installation Site.....	22
Installation Orientation and Clearances	23
Removing and Attaching the Terminal Cover.....	24
Removing/Attaching the Digital Operator and Front Cover.....	25
Electrical Installation	29
Terminal Block Configuration	30
Wiring Main Circuit Terminals.....	31
Control Wiring	40
Digital Operator	51
Digital Operator Display	52
Digital Operator Keys	53
Drive Mode Indicators	54
Drive Main Menu	55
Pump Quick Setup Menu (-QUICK-) <0032>.....	60
Programming Menu (-ADV-).....	61
Example of Changing a Parameter	63

Start Up	65
Start Up	66
iQpump Drive Start Up Procedures	69
Pump System Start/Stop	73
Pump Basics	75
Use Feedback Level to Start iQpump Controller	77
Low Feedback Level Alarm and Fault Setup	79
High Feedback Level Alarm and Fault Setup	81
Feedback Loss Detection	83
Basic Pump Protection	84
Basic Programming	87
iQpump Basic Programming Parameters	88
Pump Basic	127
Pump Protection	130
T1 Auto-Tuning	134
Diagnostics & Troubleshooting	135
Fault Detection	136
iQpump Keypad Messages	141
Alarm Detection	143
Operator Programming Errors (OPE)	146
Auto-Tuning Faults	147
Digital Operator COPY Function Faults	148
Troubleshooting	149
Main Circuit Test Procedure	153
Drive Date Stamp Information	157
Maintenance	159
Periodic Inspection	160
Preventive Maintenance	161
Heatsink Cooling Fan Replacement	162
Removing and Mounting the Terminal Card	164
Parameters	165
Parameter List	166
Monitor List	190
Fault Trace List	193
Fault History List	194

Capacity Related Parameters	197
Drive Capacity	198
Parameters Affected by o2-04	199
Capacity Related Parameter Values	200
Specifications	203
Standard iQpump Drive Specifications	204
Communication	207
Using Modbus Communication	208
Modbus Function Code Details	212
Modbus Data Tables	214
Modbus Self-Diagnosis	219
Peripheral Devices	221
Branch Circuit Short Circuit Protection	222
Branch Circuit Overload Protection	224
Peripheral Devices	224
Third Party Serial Communication Converters	
RS232-RS485 / USB - RS485 Converters	225
PumpScada Software	227
Energy Savings Estimation Software	227
EMC Compatibility	229
EMC Compatibility	230
Electromagnetic Compatibility (EMC)	231



Warnings and Cautions

This Section provides warnings and cautions pertinent to this product, that if not heeded, may result in personal injury, fatality, or equipment damage. Yaskawa is not responsible for consequences of ignoring these instructions.

WARNING

YASKAWA manufactures component parts that can be used in a wide variety of industrial applications. The selection and application of YASKAWA products remain the responsibility of the equipment designer or end user. YASKAWA accepts no responsibility for the way its products are incorporated into the final system design. Under no circumstances should any YASKAWA product be incorporated into any product or design as the exclusive or sole safety control. Without exception, all controls should be designed to detect faults dynamically and fail safely under all circumstances. All products designed to incorporate a component part manufactured by YASKAWA must be supplied to the end user with appropriate warnings and instructions as to that part's safe use and operation. Any warnings provided by YASKAWA must be promptly provided to the end user. YASKAWA offers an express warranty only as to the quality of its products in conforming to standards and specifications published in the YASKAWA manual. **NO OTHER WARRANTY, EXPRESS OR IMPLIED, IS OFFERED.** YASKAWA assumes no liability for any personal injury, property damage, losses, or claims arising from misapplication of its products.

WARNING

- Read and understand this manual before installing, operating, or servicing this Drive. All warnings, cautions, and instructions must be followed. All activity must be performed by qualified personnel. The iQpump drive must be installed according to this manual and local codes.
- Do not connect or disconnect wiring while the power is on. Do not remove covers or touch circuit boards while the power is on. Do not remove or insert the digital operator while power is on.
- Before servicing, disconnect all power to the equipment. The internal capacitor remains charged even after the power supply is turned off. Status indicator LEDs and Digital Operator display will be extinguished when the DC bus voltage is below 50 Vdc. To prevent electric shock, wait at least five minutes after all indicators are OFF and measure DC bus voltage level to confirm safe level.
- Do not perform a withstand voltage test on any part of the unit. This equipment uses sensitive devices and may be damaged by high voltage.
- The iQpump drive is not suitable for circuits capable of delivering more than 100,000 RMS symmetrical amperes. Install adequate branch short circuit protection per applicable codes. Refer to the specification. Failure to do so may result in equipment damage and/or personal injury.
- Do not connect unapproved LC or RC interference suppression filters, capacitors, or overvoltage protection devices to the output of the Drive. These devices may generate peak currents that exceed iQpump drive specifications.
- To avoid unnecessary fault displays caused by contactors or output switches placed between iQpump drive and motor, auxiliary contacts must be properly integrated into the control logic circuit.
- YASKAWA is not responsible for any modification of the product made by the user; doing so will void the warranty. This product must not be modified.
- Verify that the rated voltage of the iQpump drive matches the voltage of the incoming power supply before applying power.
- To meet CE directives, proper line filters and proper installation are required.
- Some drawings in this manual may be shown with protective covers or shields removed, to describe details. These must be replaced before operation.
- Observe electrostatic discharge procedures when handling circuit cards to prevent ESD damage.
- The equipment may start unexpectedly upon application of power. Clear all personnel from the drive, motor, and machine area before applying power. Secure covers, couplings, shaft keys, and machine loads before energizing the Drive.
- Please do not connect or operate any equipment with visible damage or missing parts. The operating company is responsible for any injuries or equipment damage resulting from failure to heed the warnings in this manual.

◆ **Intended Use**

Drives are intended for installation in electrical systems or machinery.

For use in the European Union, the installation in machinery and systems must conform to the following product standards of the Low Voltage Directive:

- EN 50178, 1997-10, Equipping of Power Systems with Electronic Devices
- EN 60201-1, 1997-12 Machine Safety and Equipping with Electrical Devices
- Part 1: General Requirements (IEC 60204-1:1997)
- EN 61010, 1997-11 Safety Requirements for Information Technology Equipment
- (IEC 950:1991 + A1:1992 + A2:1993 + A3:1995 + A4:1996, modified)

◆ **Other**

The iQpump (P7U) Drive is suitable for use on a circuit capable of delivering not more than 100,000 RMS symmetrical amperes, 240 Vac maximum (240 V Class) and 480 Vac maximum (480 V Class).



Introduction

This Section describes the applicability of the Manual.

The iQpump (P7U) is a Pulse Width Modulated Drive for 3-Phase AC induction motors. This type of Drive is also known as an Adjustable Frequency Drive, Variable Frequency Drive, AC Drive, AFD, ASD, VFD, and Inverter.

The iQpump (P7U) is a variable torque AC drive, designed specifically for Simplex and Multiplex pumping applications. The pump applications include Booster Systems, Submersible Deep Well, Fluid Storage Tanks, Metering Pumps, Commercial and Residential Irrigation Systems.

The iQpump (P7U) sets a new benchmark for size, cost, performance, ease-of-use benefits, comprehensive pump and motor protection features, and quality. The iQpump (P7U) includes numerous built-in features such as H/O/A Operation, Selectable Pump Control Engineering Units, PI Control, Pump Basic Control, Pump Protection, Multi-Pump Control (Lead/Lag), and Pump Messaging Terminology.

The LCD keypad/operator is equipped with Hand/Off/Auto functions, copy feature, and 5 lines of display with 16 characters per line.

Built-in PI and pump specific functions and parameters allow the operator to setup specific control values for a wide range of applications. The iQpump (P7U) will optimize the pump performance by automatically adjusting the pump controller based on operating conditions of the pump; such as, process variable changes and pump protection requirements. The P Group programming parameters are dedicated for pumping applications and provide for ease of setup.

The iQpump (P7U) drive offers energy savings by controlling the flow rate and the number of operating pumps on the system. The iQpump (P7U) can be configured using the most popular system control configurations including Simplex, Duplex, and Triplex pumps systems. The iQpump (P7U) is the master controller with the ability to add additional pumps on-line by controlling the digital I/O to each individual motor starter.

The iQpump (P7U) has an optional feature to replace the motors starters with additional drives for a more precise pump control system.

This manual is applicable to the iQpump (P7U) Drives defined by models CIMR-P7U□-107. This manual is subject to change as product improvements occur. The latest version of the manual can be obtained from the Yaskawa. The date shown on the rear cover is changed when revisions are made.

This manual may describe trademarked equipment, which is the property of other companies. These trademarks are the property of the registered owner companies and may include the following:

- Modbus[®], trademark of Schneider Automation, Inc.

Other Documents and Manuals are available to support special use or installation of this product. These documents may be provided with the product or upon request. Contact Yaskawa Electric America, Inc. as required. Documents may include the following:

- TM.iQp.02 Programming Manual
- TM.iQp.11 Modbus Manual
- PumpScada Software and Manual included on CD ROM with product
- Option Instructions included on CD ROM with product

Conventions Used in this Manual

Software Versions

Yaskawa recognizes the need to continuously improve product quality. This drive may receive feature enhancements in the form of software or hardware changes. New functions may be added to the drive. When a new feature or function is added, the **software version <####>** will be placed next to the feature or function.

EXAMPLE: This example shows that settings 2,3,4,5,6 are added to parameter A1-00 for drive software version <3020>

A1-00 Language Selection

Select Language

Q	Q	Q	Q
---	---	---	---

Select the language displayed on the digital operator according to the following table:

Setting	Description
0	English (<i>factory default</i>)
1	Japanese
2	Deutsche <3020>
3	Francais <3020>
4	Italiano <3020>
5	Espanol <3020>
6	Portugues <3020>

In the example above, the version note <3020> indicates that five additional languages have been added with drive software version 3020. Check the drive nameplate to determine the drive software version.

EXAMPLE: Nameplate with PRG software number:

The “PRG:” number on the drive nameplate reflects the software version. The software version normally increases to a higher number with newer versions. Please consult the factory for details.

MODEL: CIMR-F7U2018	SPEC: 20181E
INPUT: AC3PH 200-240V 50/60Hz HD:84A ND:89A	
OUTPUT: AC3PH 0-240V 0-400Hz HD:71A 27kVA ND:74.8A 29kVA	
O/N:	MASS: 11kg
S/N: 1W9911234560123	PRG: 3020
	
FILE NO: E131457	TYPE 1 ENCLOSURE IP20

← Drive Software version

Nameplate



Physical Installation

This chapter describes the requirements for receiving and installing the iQpump drive.

1.1 iQpump Model Number and Enclosure Style	12
1.2 Confirmations Upon Delivery	13
1.3 Component Names	15
1.4 Exterior and Mounting Dimensions	17
1.5 Heat Loss Data	21
1.6 Checking and Controlling the Installation Site	22
1.7 Installation Orientation and Clearances	23
1.8 Removing and Attaching the Terminal Cover	24
1.9 Removing/Attaching the Digital Operator and Front Cover	25

1.1 iQpump Model Number and Enclosure Style

Table 1.1 iQpump Model Numbers and Enclosure Style

Input Voltage 3-Phase	iQpump Model-Number CIMR-P7U□-107	Enclosure Style	Rated Output Current	Nominal Hp
208-240 VAC	20P4	NEMA Type 1 (IP20)	3.6	0.5/0.75
	20P7	NEMA Type 1 (IP20)	4.6	1
	21P5	NEMA Type 1 (IP20)	7.8	1.5/2
	22P2	NEMA Type 1 (IP20)	10.8	3
	23P7	NEMA Type 1 (IP20)	16.8	5
	25P5	NEMA Type 1 (IP20)	23.0	7.5
	27P5	NEMA Type 1 (IP20)	31.0	7.5/10
	2011	NEMA Type 1 (IP20)	46.2	15
	2015	NEMA Type 1 (IP20)	59.4	20
	2018	NEMA Type 1 (IP20)	74.8	25
208-230 VAC	2022	NEMA Type 1 (IP20)	88.0	30
	2030	NEMA Type 1 (IP20)	115.0	40
	2037	Open Chassis (IP00)	162.0	50/60
	2045	Open Chassis (IP00)	192.0	60/75
	2055	Open Chassis (IP00)	215.0	75
	2075	Open Chassis (IP00)	312.0	100/125
480 VAC	2090	Open Chassis (IP00)	360.0	125/150
	2110	Open Chassis (IP00)	415.0	150
	40P4	NEMA Type 1 (IP20)	1.8	0.5/0.75
	40P7	NEMA Type 1 (IP20)	2.1	1
	41P5	NEMA Type 1 (IP20)	3.7	1.5/2
	42P2	NEMA Type 1 (IP20)	5.3	3
	43P7	NEMA Type 1 (IP20)	7.6	5
	45P5	NEMA Type 1 (IP20)	12.5	7.5
	47P5	NEMA Type 1 (IP20)	17.0	10
	49P0	NEMA Type 1 (IP20)	21.0	15
	4011	NEMA Type 1 (IP20)	27.0	20
	4015	NEMA Type 1 (IP20)	34.0	25
	4018	NEMA Type 1 (IP20)	40.0	30
	4024	NEMA Type 1 (IP20)	52.0	40
	4030	NEMA Type 1 (IP20)	67.2	50
	4037	NEMA Type 1 (IP20)	77.0	60
	4045	NEMA Type 1 (IP20)	96.0	75
	4055	NEMA Type 1 (IP20)	125.0	100
	4075	Open Chassis (IP00)	156.0	125
	4090	Open Chassis (IP00)	180.0	150
4110	Open Chassis (IP00)	240.0	200	
4160	Open Chassis (IP00)	304.0	250	
4185	Open Chassis (IP00)	414.0	300/350	
4220	Open Chassis (IP00)	515.0	400/450	
4300	Open Chassis (IP00)	675.0	500+	

1.2 Confirmations Upon Delivery

◆ Receiving Checks

Check the following items as soon as the iQpump drive is received.

Table 1.2 Receiving Checks

Item	Method
Has the correct model of iQpump drive been delivered?	Check the model number on the nameplate on the right side of the iQpump drive. Reconcile with packing slip and/or order information.
Is the iQpump drive damaged in any way?	Inspect the entire exterior of the iQpump drive to see if there are any dents, scratches or other damage resulting from shipping.
Are any screws or other components loose?	Use a screwdriver or other tool to check for tightness.

If there are any irregularities in the above items, contact the shipping company, the distributor or representative who sold the iQpump drive, or a Yaskawa office immediately.

The iQpump drive is thoroughly tested at the factory. Any damages or shortages evident when the equipment is received must be reported immediately to the commercial carrier that transported the material. Shipping damage is not covered by the Yaskawa warranty. After unpacking and inspecting for damage, verify that internal wire connections have not come loose during shipment by spot checking wire terminations with a screwdriver or the appropriate tool.

iQpump drive storage must be in a clean and dry location. Maintain the factory packaging and provide covering as needed to protect the iQpump from construction site dirt, water, debris and traffic prior to and during construction.

◆ Nameplate Information

A nameplate is attached to the right side of each iQpump drive. The following nameplate is an example for a standard iQpump drive.

■ Normal P7

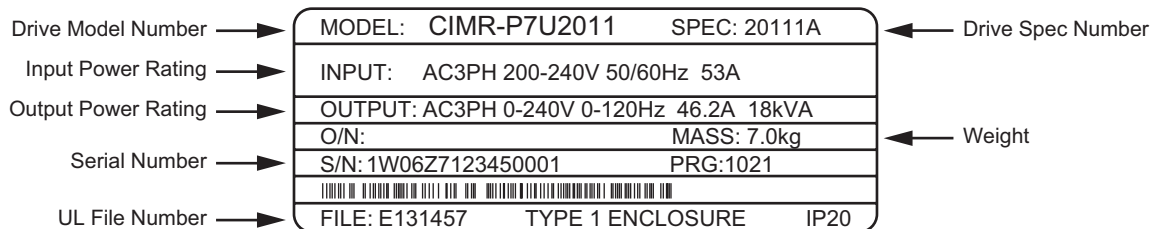

■ P7 iQpump

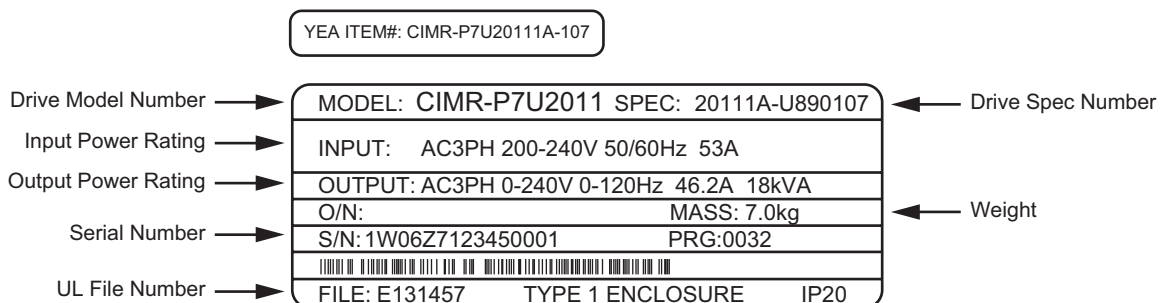

Note: The iQpump Drive Model Number and iQpump Drive Spec Number are required to completely identify an iQpump Drive.

Figure 1.1 iQpump (P7U) Drive Nameplate

◆ Drive Model Numbers

The model number on the nameplate indicates the design specification, voltage, and rating of the iQpump drive in alphanumeric codes.

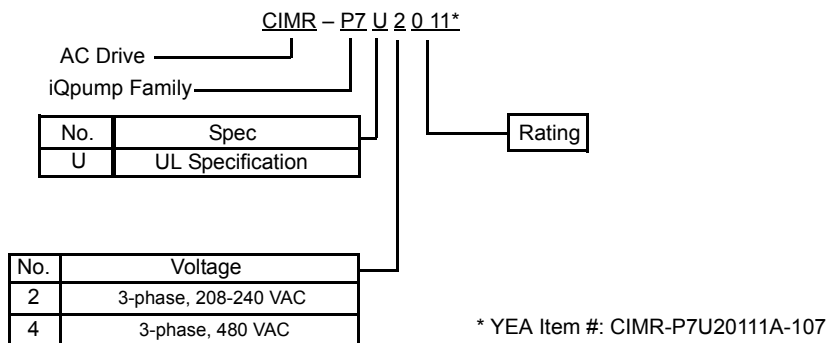

Figure 1.2 iQpump Drive Model Number Structure

◆ Drive Enclosure and Revision Code

The iQpump drive SPEC number on the nameplate indicates the voltage, iQpump drive rating, enclosure type, and the revision code of the iQpump drive in alphanumeric codes.

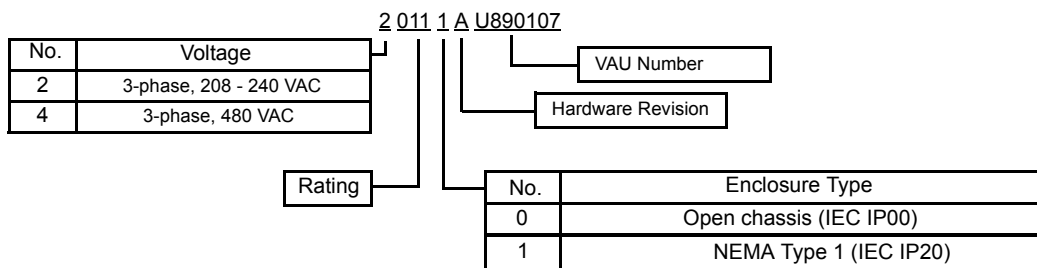

Figure 1.3 SPEC Number Structure



Open Chassis Type (IEC IP00)

Protected so that parts of the human body cannot reach electrically charged parts from the front when the iQpump drive is mounted in a control panel, also called (protected chassis).



NEMA Type 1 (IEC IP20)

The iQpump drive is shielded from the exterior, and can thus be mounted to the interior wall of a building (not necessarily enclosed in a control panel). The protective structure conforms to the standards of NEMA Type 1 in the USA. All protective covers (Fig 1.4) must be installed to conform with IEC IP20 and NEMA Type 1 requirements

1.3 Component Names

◆ Models CIMR-P7U20P4 through 2018 (25HP @ 208V/240V) and 40P4 through 4018 (30HP @ 480V)

The external appearance, component names, and terminal arrangement of the iQpump drive are shown in [Figure 1.4](#) and [Figure 1.5](#).

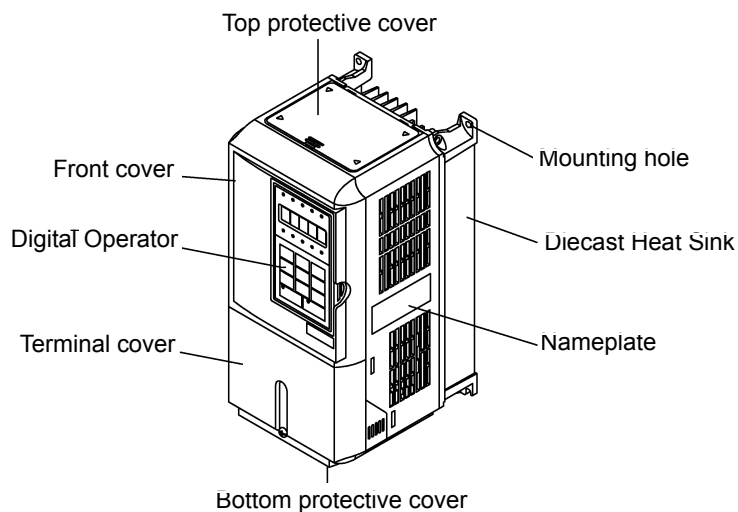

Figure 1.4 iQpump Drive Appearance

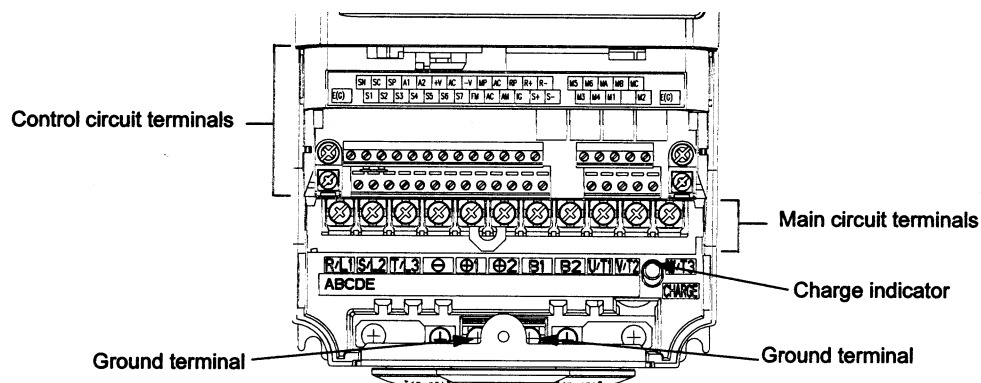

Figure 1.5 Terminal Arrangement (Terminal Cover Removed)

1.3 Component Names

◆ Models CIMR-P7U2022 through 2110 (30HP and above @ 208V/240V) and 4030 through 4300 (40HP and above @ 480V)

The external appearance, component names, and terminal arrangement of the iQpump drive are shown in *Figure 1.6* and *Figure 1.7*.

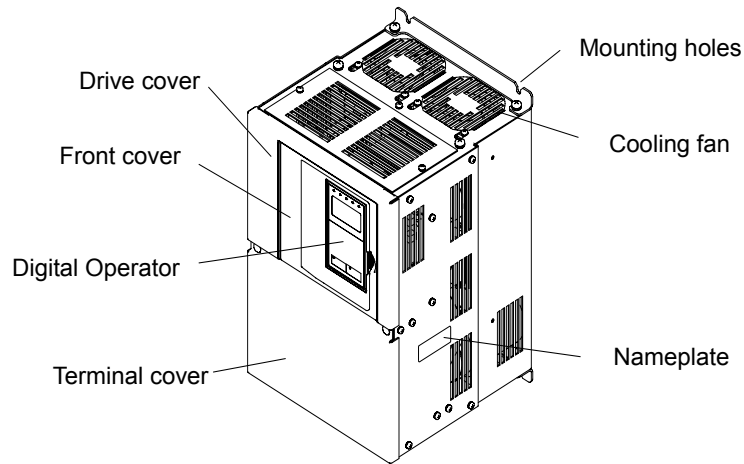

Figure 1.6 iQpump Drive Appearance

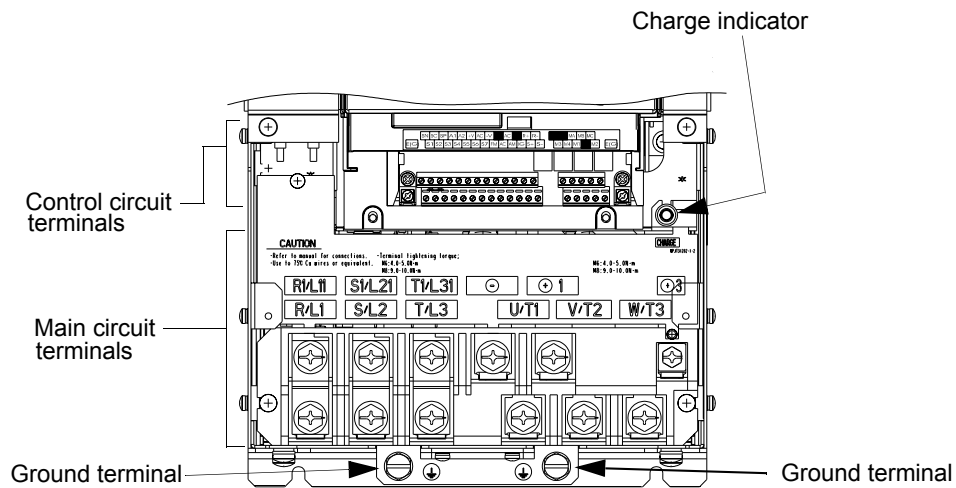

Figure 1.7 Terminal Arrangement (Terminal Cover Removed)

1.4 Exterior and Mounting Dimensions

Dimensions: iQpump (P7U) (NEMA 1) 208 V/240 V (3.6–74.8 AMPS) 480 V (1.8–40.0 AMPS)

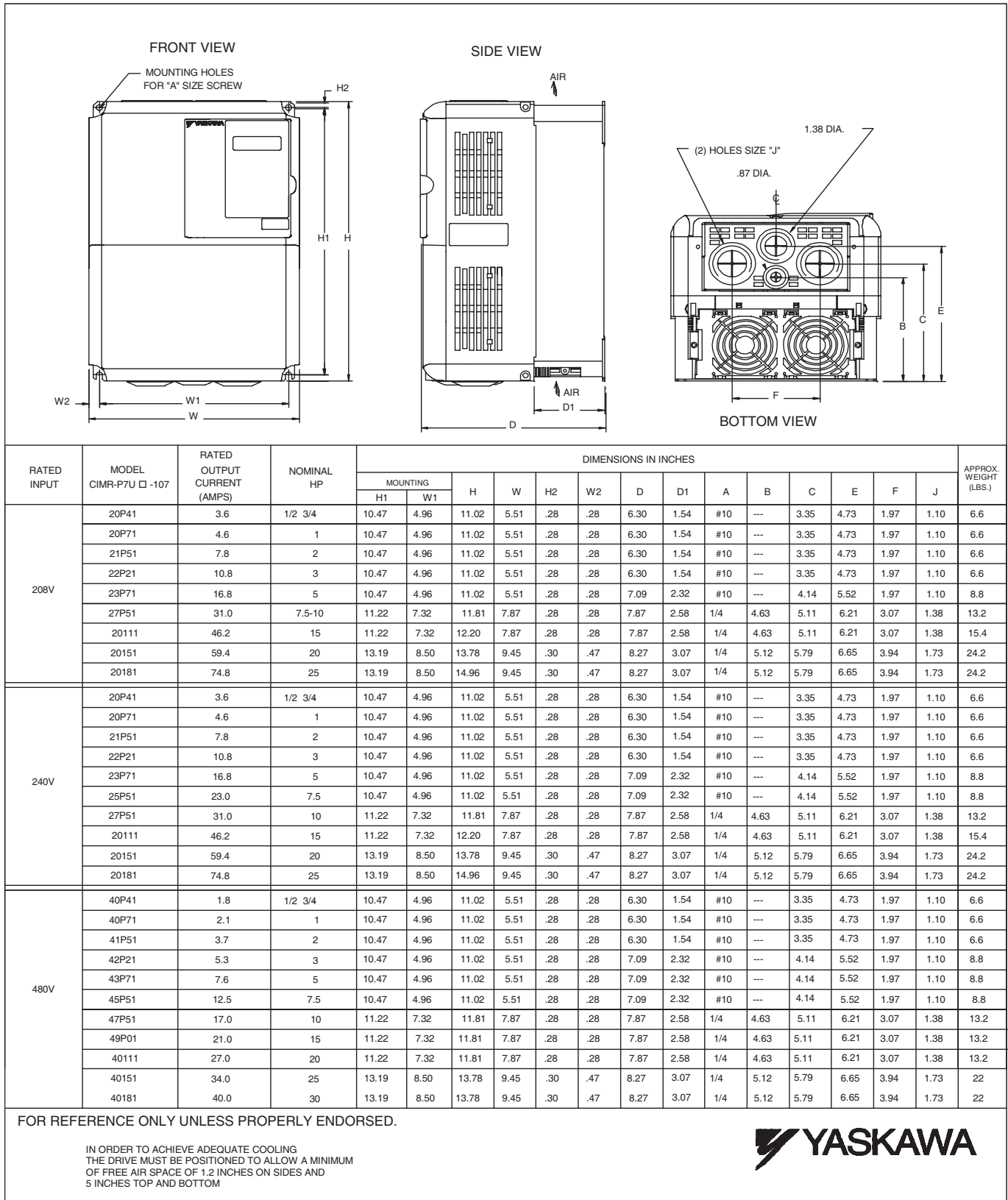
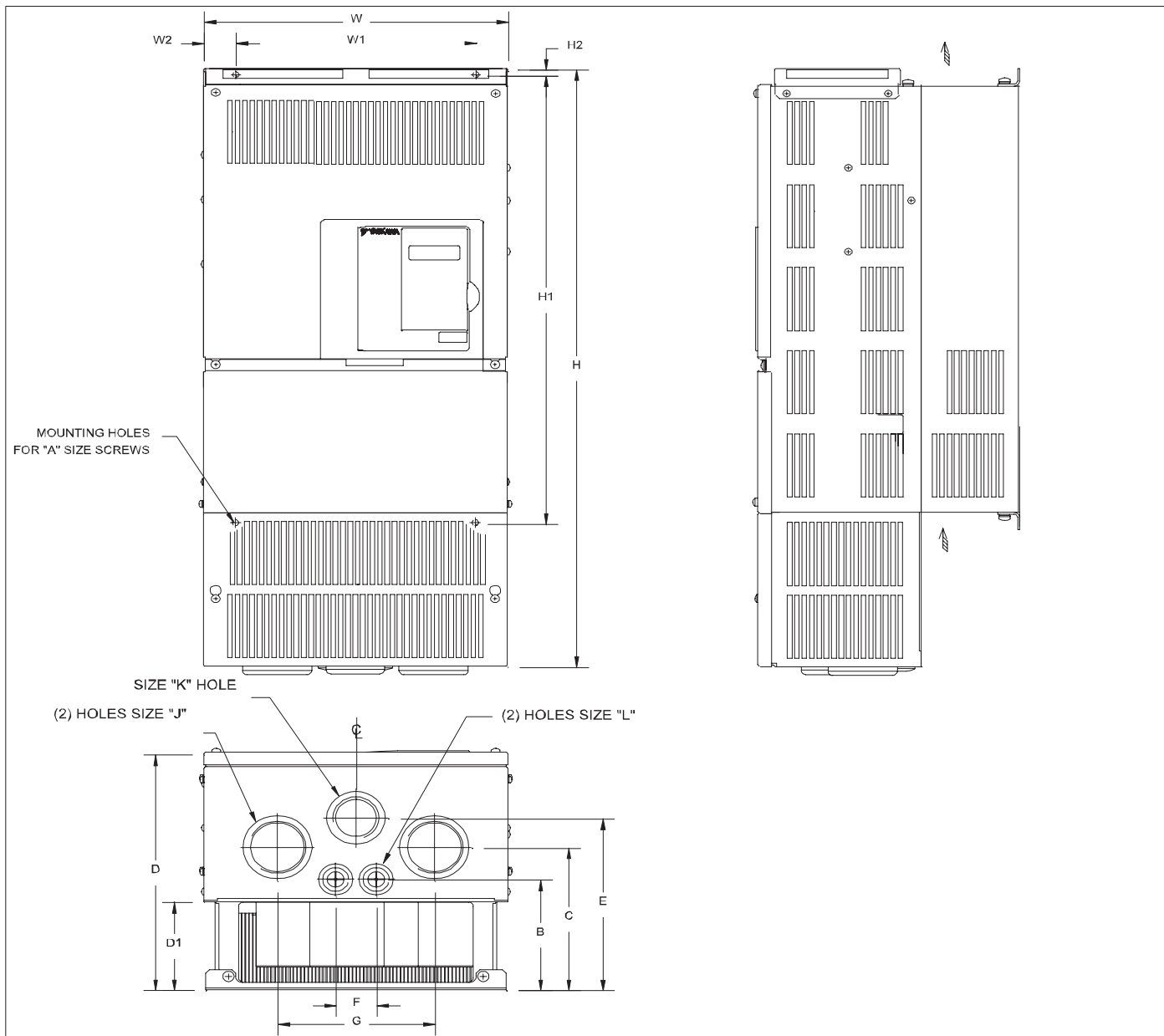

Figure 1.8 Exterior and Mounting Dimensions

1.4 Exterior and Mounting Dimensions

Dimensions: iQpump (P7U) (NEMA 1) 208 V/240 V (88.0–115 AMPS) 480 V (52.0–125 AMPS)



RATED INPUT	MODEL CIMR-P7U	RATED OUTPUT CURRENT (AMPS)	NOM. HP	DIMENSIONS IN INCHES																	APPROX. WEIGHT (LBS.)
				MOUNTING		H	W	H2	W2	D	D1	A	B	C	E	F	G	J	K	L	
				H1	W1																
208V	20221	88.0	30	15.16	7.68	21.06	10.00	.30	1.16	10.24	3.94	1/4	4.98	6.50	7.87	1.73	5.91	2.44	1.97	1.10	53
	20301	115	40	17.13	8.66	24.21	10.98	.30	1.16	10.24	3.94	1/4	4.98	6.50	7.87	1.73	5.91	2.44	1.97	1.10	59
240V	20221	88.0	30	15.16	7.68	21.06	10.00	.30	1.16	10.24	3.94	1/4	4.98	6.50	7.87	1.73	5.91	2.44	1.97	1.10	53
	20301	115	40	17.13	8.66	24.21	10.98	.30	1.16	10.24	3.94	1/4	4.98	6.50	7.87	1.73	5.91	2.44	1.97	1.10	59
480V	40241	52.0	40	17.13	8.66	21.06	10.98	.30	1.16	10.24	3.94	1/4	4.98	6.50	7.87	1.73	5.91	1.97	1.97	1.10	53
	40301	67.2	50	17.13	8.66	21.06	10.98	.30	1.16	10.24	3.94	1/4	4.98	6.50	7.87	1.73	5.91	1.97	1.97	1.10	53
	40371	77.0	60	21.06	10.24	25.00	12.95	.30	1.36	11.22	4.13	1/4	5.18	6.69	8.07	1.73	6.69	1.97	1.97	1.10	88
	40451	96.0	75	21.06	10.24	28.15	12.95	.30	1.36	11.22	4.13	1/4	5.18	6.69	8.07	1.73	6.69	2.44	1.97	1.10	88
	40551	125	100	21.06	10.24	28.15	12.95	.30	1.36	11.22	4.13	1/4	5.18	6.69	8.07	1.73	6.69	2.44	1.97	1.10	88

FOR REFERENCE ONLY UNLESS PROPERLY ENDORSED.

IN ORDER TO ACHIEVE ADEQUATE COOLING THE DRIVE MUST BE POSITIONED TO ALLOW A MINIMUM OF FREE AIR SPACE OF 1.2 INCHES ON SIDES AND 5 INCHES TOP AND BOTTOM



Figure 1.9 Exterior and Mounting Dimensions

Dimensions: iQpump (P7U) (Protected Chassis) 208–230 V (162–415 AMPS) 480 V (156–304 AMPS)

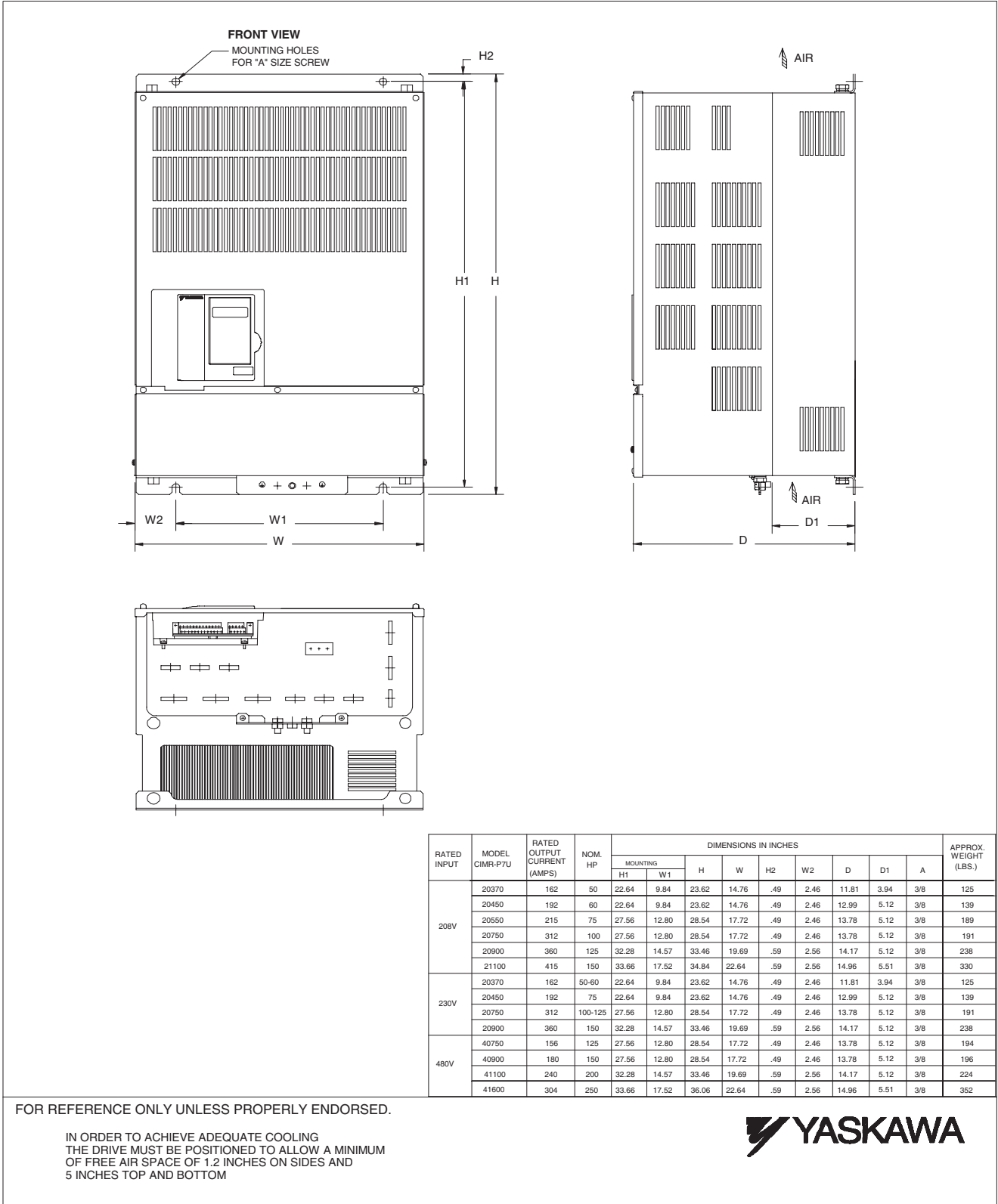
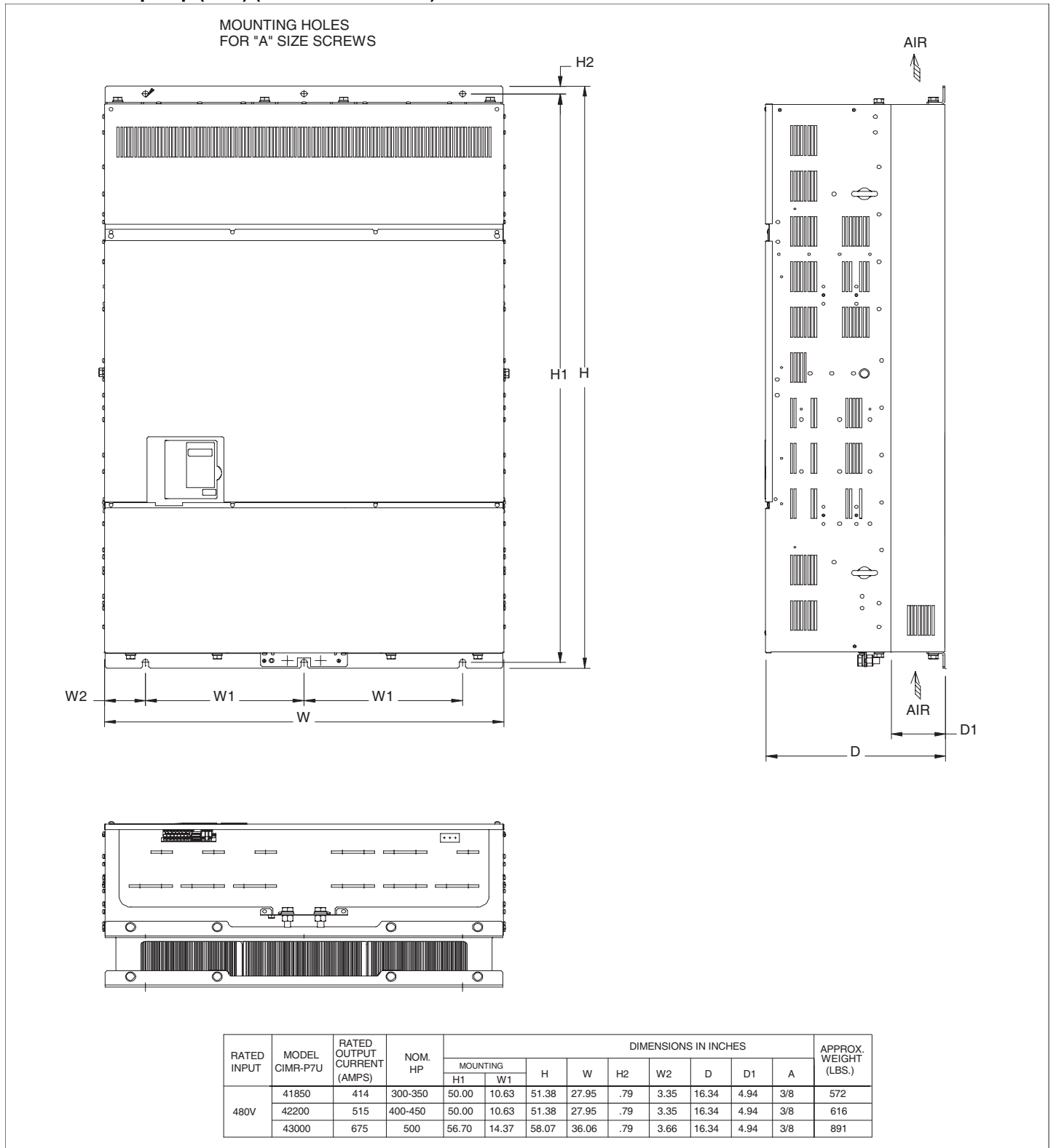

Figure 1.10 Exterior and Mounting Dimensions

1.4 Exterior and Mounting Dimensions

Dimensions: iQpump (P7U) (Protected Chassis)



FOR REFERENCE ONLY UNLESS PROPERLY ENDORSED.

IN ORDER TO ACHIEVE ADEQUATE COOLING
THE DRIVE MUST BE POSITIONED TO ALLOW A MINIMUM
OF FREE AIR OF 1.2 INCHES ON SIDES AND
5 INCHES TOP AND BOTTOM



Figure 1.11 Exterior and Mounting Dimensions

1.5 Heat Loss Data

Table 1.3 200V Class Heat Loss Data

TYPE CIMR-P7U□-107	Drive (Inverter) Capacity (kVA)	Rated Output Current (A)	Cooling Fin Side (W)	Internal Unit Side (W)	Total Watt Loss (W)	Cooling Method
20P4	1.4	3.6	19	39	58	Self
20P7	1.8	4.6	26	42	68	Self
21P5	3.0	7.8	48	50	98	Self
22P2	4.1	10.8	68	59	127	Self
23P7	6.4	16.8	110	74	184	Fan
25P5	8.8	23	164	84	248	Fan
27P5	12	31	219	113	332	Fan
2011	18	46.2	357	168	524	Fan
2015	23	59.4	416	182	597	Fan
2018	29	74.8	472	208	680	Fan
2022	34	88	583	252	835	Fan
2030	44	115	883	333	1217	Fan
2037	62	162	1010	421	1430	Fan
2045	73	192	1228	499	1727	Fan
2055	82	215	1588	619	2206	Fan
2075	120	312	1956	844	2800	Fan
2090	140	360	2194	964	3157	Fan
2110	160	415	2733	1234	3967	Fan

Table 1.4 400V Class Heat Loss Data

TYPE CIMR-P7U□-107	Drive (Inverter) Capacity (kVA)	Rated Output Current (A)	Cooling Fin Side (W)	Internal Unit Side (W)	Total Watt Loss (W)	Cooling Method
40P4	1.4	1.8	14	39	53	Self
40P7	1.6	2.1	17	41	58	Self
41P5	2.8	3.7	36	48	84	Self
42P2	4.0	5.3	59	56	115	Fan
43P7	5.8	7.6	80	68	140	Fan
44P0	6.6	8.7	90	70	160	Fan
45P5	9.5	12.5	127	81	209	Fan
47P5	13	17	193	114	307	Fan
49P0	16	21	232	158	390	Fan
4011	21	27	232	158	390	Fan
4015	26	34	296	169	465	Fan
4018	30	40	389	201	590	Fan
4022	38	50.4	420	233	653	Fan
4024	40	52	691	297	989	Fan
4030	51	67.2	691	297	989	Fan
4037	59	77	801	332	1133	Fan
4045	73	96	901	386	1287	Fan
4055	95	125	1204	478	1682	Fan
4075	120	156	1285	562	1847	Fan
4090	140	180	1614	673	2287	Fan
4110	180	240	1889	847	2736	Fan
4132	200	260	2388	1005	3393	Fan
4160	230	304	2636	1144	3936	Fan
4185	315	414	2791	1328	3964	Fan
4220	390	515	3797	1712	5509	Fan
4300	510	675	5838	2482	8319	Fan

1.6 Checking and Controlling the Installation Site

Install the iQpump drive as described below and maintain optimum conditions.

WARNING

The iQpump drive heatsink temperature may exceed 158°F (70°C). Therefore, mount the iQpump drive to a surface suitable for high temperature.

◆ Installation Site

Locate the iQpump drive as close as possible to the motor. Install the iQpump drive under the following conditions in UL Pollution Degree 1 & 2 environments. This excludes wet locations where surfaces may become conductive due to moisture and contaminant loading.

Table 1.5 Installation Site Specifications

Type	Ambient Operating Temperature	Humidity	Plenum Rated
NEMA Type 1	14°F to 104°F (-10 to 40°C)	95% RH or less (no condensation)	Yes
Open Chassis	14°F to 113°F (-10 to +45°C)	95% RH or less (no condensation)	No

Protective covers are attached to the top and bottom of the iQpump drive. It is recommended to remove the protective covers before operating a CIMR-P7U2030/4055-107 iQpump drive and smaller in a panel to obtain the 113°F (45°C) ambient operating temperature.

Observe the following precautions when installing the iQpump drive:

- in a clean location which is free from oil mist and dust.
- in an environment where metal shavings, oil, water, or other foreign materials will not get into the iQpump drive enclosure.
- in a location free from radioactive materials.
- in a location free from harmful gasses and liquids.
- in a location free from excessive vibration.
- in a location free from chlorides.
- in a location away from direct sunlight.
- on a non-combustible surface.

◆ Controlling the Ambient Temperature

To enhance the reliability of operation, the iQpump drive should be installed in an environment free from extreme temperature variations. If the iQpump drive is installed in an enclosure, use a cooling fan or air conditioner to maintain the internal air temperature below 113°F (45°C).

◆ Protecting the iQpump Drive from Foreign Matter

During iQpump drive installation and project construction it is possible to have foreign matter, such as metal shavings or wire clippings, fall inside the iQpump drive. To prevent foreign matter from falling into the iQpump drive, place a temporary cover over the iQpump drive.

Always remove the temporary cover from the iQpump drive before Start-Up. Otherwise, ventilation will be reduced, causing the iQpump drive to overheat.

1.7 Installation Orientation and Clearances

Install the iQpump drive vertically so as not to reduce the cooling efficiency. When installing the iQpump drive, always provide the following installation clearances to allow normal heat dissipation. For 3HP, 208V/240V (CIMR-P7U22P2-107 and below) or 2HP, 480V (CIMR-P7U41P-107 and below), ensure that the heatsink is against a closed surface to avoid diverting cooling air around the heatsink.

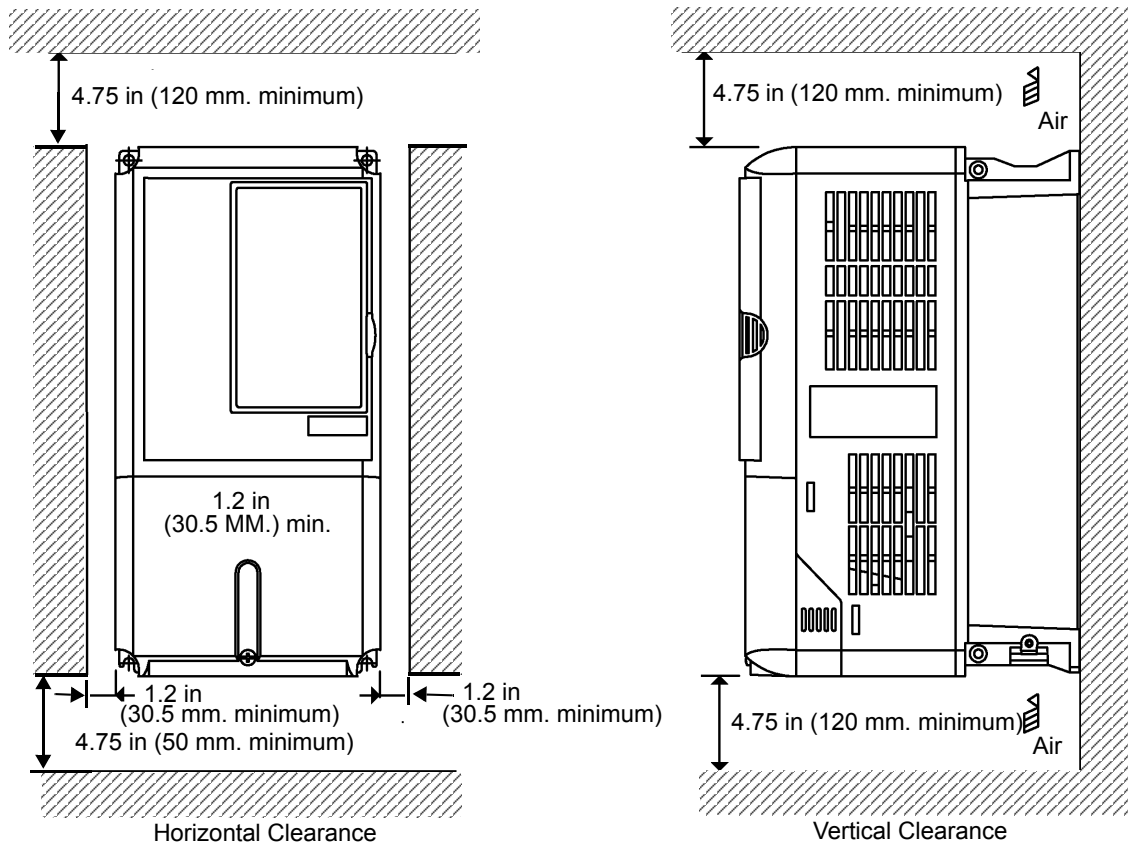

Figure 1.12 iQpump Drive Installation Orientation and Clearance

IMPORTANT

- The same clearance is required horizontally and vertically for both Open Chassis (IP00) and NEMA Type 1 iQpump drives.
1. Always remove the top and bottom protection covers before installing a CIMR-P7U2018/4018-107 and smaller iQpump drive in a panel. Always provide enough clearance for lifting eye bolts and the main circuit wiring when installing a CIMR-P7U2022/4030-107 and larger iQpump drive in a panel.

1.8 Removing and Attaching the Terminal Cover

Remove the terminal cover to connect cables to the control circuit and main circuit terminals.

⚠ WARNING

Prior to removing any protective cover or wiring any part of the iQpump drive, remove all power sources, including main input power and control circuit power. Wait a minimum of 5 minutes after power removal, before removing any cover. The charge lamp located within the iQpump drive should be off prior to working inside. Even if the charge lamp is off, one must measure the AC input, output, and DC Bus potential to insure safe levels prior to resuming work. Failure to adhere to this warning may result in personal injury or death.

◆ Removing the Terminal Cover

■ Models CIMR-P7U20P4 through 2018 (0.5HP to 25HP @ 208V/240V) and 40P4 through 4018 (0.5HP to 30HP @ 480V)

Loosen the screw at the bottom of the terminal cover, press in on the sides of the terminal cover in the directions of arrows 1, and then lift up on the terminal in the direction of arrow 2. Refer to [Figure 1.13](#).

■ Models CIMR-P7U2022 through 2110 (30HP to 150HP @ 208V/240V) and 4030 through 4300 (40HP to 500HP @ 480V)

Loosen the screws on the left and right at the top of the terminal cover, pull down the terminal cover in the direction of arrow 1 and then lift up on the terminal cover in the direction of arrow 2. Refer to [Figure 1.14](#).

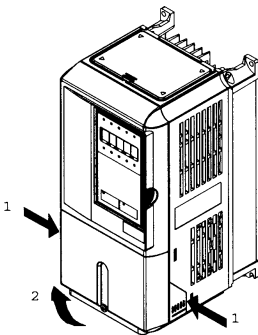

Figure 1.13 Removing the Terminal Cover

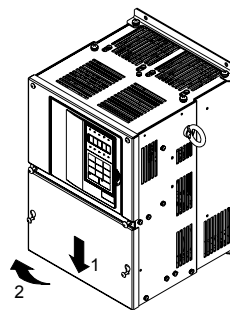

Figure 1.14 Removing the Terminal Cover

◆ Attaching the Terminal Cover

After wiring the terminal block, attach the terminal cover by reversing the removal procedure.

For Models CIMR-P7U2018/4018-107 and smaller, insert the tab on the top of the terminal cover into the groove on the iQpump drive and press in on the bottom of the terminal cover until it snaps into place.

For iQpump drives CIMR-P7U2022/4030-107 and larger, insert the tab on the top of the terminal cover into the groove on the iQpump drive, and secure the terminal cover by lifting it up toward the top of the iQpump drive.

1.9 Removing/Attaching the Digital Operator and Front Cover

◆ Models CIMR-P7U20P4 through 2018 (0.5HP to 25HP @ 208V/240V) and 40P4 through 4018 (0.5HP to 30HP @ 480V)

For Models CIMR-P7U2018/4018-107 and smaller, remove the terminal cover and then use the following procedures to remove the Digital Operator and front cover.

■ Removing the Digital Operator

Press on the side of the Digital Operator in the direction of arrow 1 to unlock, then lift the Digital Operator in the direction of arrow 2 to remove it as shown in *Figure 1.15*.

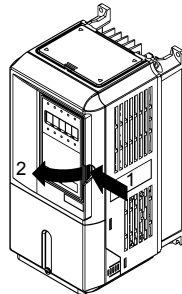

Figure 1.15 Removing the Digital Operator

■ Removing the Front Cover

Press the left and right sides of the front cover in the direction of arrows 1 and lift the bottom of cover in the direction of arrow 2 to remove it as shown in *Figure 1.16*.

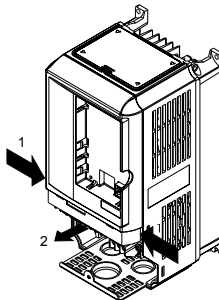

Figure 1.16 Removing the Front Cover

■ Attaching the Front Cover

Mount the front cover to the iQpump drive by performing the steps to remove the front cover in reverse order.

1. Do not mount the front cover with the Digital Operator attached to the front cover; this may cause the Digital Operator to malfunction due to imperfect contact.
2. Insert the tab of the upper part of the front cover into the groove of the iQpump drive and press the lower part of the front cover onto the iQpump drive until the front cover snaps into place.

1.9 Removing/Attaching the Digital Operator and Front Cover

◆ Models CIMR-P7U2022 through 2110 (30HP to 150HP @ 208V/240V) and 4030 through 4300 (40HP to 500HP @ 480V)

For Models CIMR-P7U2022/4030-107 and larger, remove the terminal cover and then use the following procedures to remove the Digital Operator and front cover.

■ Removing the Digital Operator

Use the same procedure for Models CIMR-P7U2018/4018-107 and smaller.

■ Removing the Front Cover

Loosen all screws on the front cover. Lift up at the location labeled 1 at the top of the control circuit terminal card and move in the direction of arrow 2.

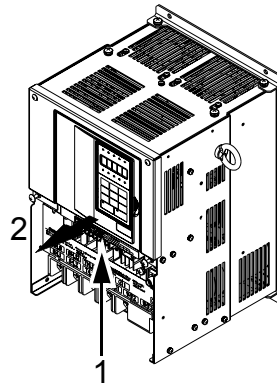

Figure 1.17 Removing the Front Cover

■ Attaching the Front Cover

Attach the front cover by reversing the procedure to remove it.

1. Confirm that the Digital Operator is not mounted on the front cover. Contact faults can occur if the cover is attached while the Digital Operator is mounted to it.
2. Insert the tab on the top of the front cover into the slot on the iQpump drive and press in on the cover until it snaps into place on the iQpump drive.

■ Attaching the Digital Operator

After attaching the front cover, mount the Digital Operator onto the iQpump drive using the following procedure.

1. Hook the Digital Operator at A (two locations) on the front cover by moving in the direction of arrow 1 as shown in the following illustration.
2. Press the Digital Operator in the direction of arrow 2 until it snaps in place at B (two locations).

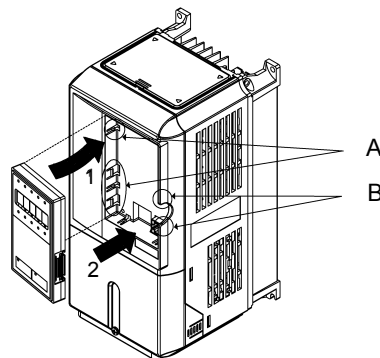

Figure 1.18 Mounting the Digital Operator

IMPORTANT

- Do not remove or attach the Digital Operator or mount or remove the front cover using methods other than those described above, damage to the Digital Operator or iQpump drive may occur.
- Never attach the front cover to the iQpump drive with the Digital Operator attached to the front cover. Damage to the Digital Operator may occur. Always attach the front cover to the iQpump drive first, and then attach the Digital Operator to the front cover.

THIS PAGE INTENTIONALLY LEFT BLANK.



Electrical Installation

This chapter describes wiring terminals, main circuit terminal connections, main circuit terminal wiring specifications, control circuit terminals, and control circuit wiring specifications.

2.1 Terminal Block Configuration	30
2.2 Wiring Main Circuit Terminals	31
2.3 Control Wiring	40

2.1 Terminal Block Configuration

The wiring terminals are shown in *Figure 2.1*.

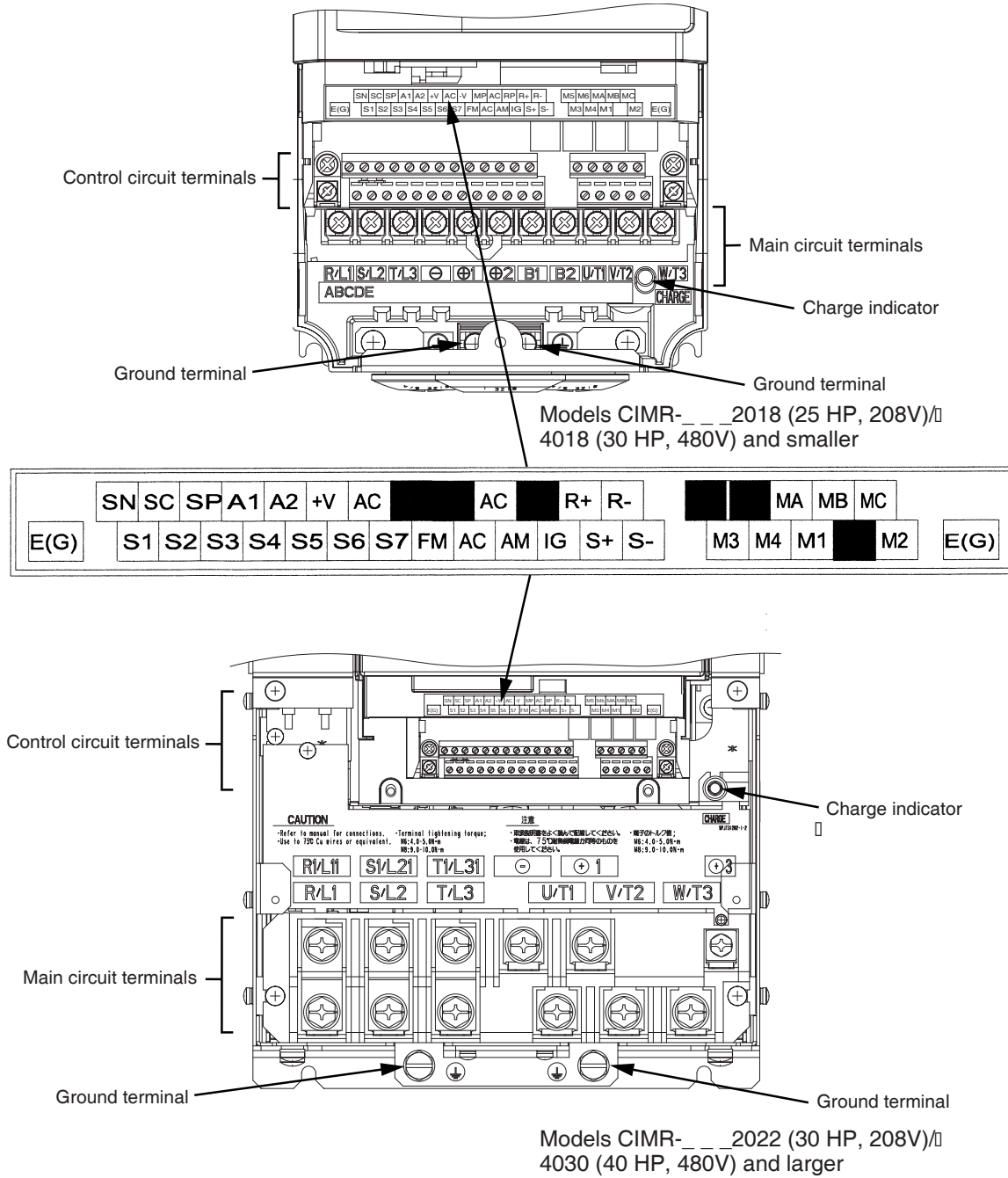

Figure 2.1 iQpump Drive Terminal Configuration

2.2 Wiring Main Circuit Terminals

◆ Applicable Wire Sizes and Closed-Loop Connectors

Select the appropriate wires and crimp terminals from [Table 2.1](#) to [Table 2.2](#).

Table 2.1 208-240 VAC Wire Sizes and Connector Specifications

Drive Model CIMR-P7U□-107	Nominal Hp	Terminal Symbol	Terminal Screws	Clamping Torque lb. in. (N·m)	Recommended Wire Size AWG (mm ²)	Wire Type
20P4	0.5/0.75	R/L1, S/L2, T/L3, ⊖, ⊕1, ⊕2, B1, B2, U/T1, V/T2, W/T3	M4	13.3 (1.5)	14 (2.1)	600 VAC UL Approved vinyl-sheathed or equivalent
		⊖				
20P7	2	R/L1, S/L2, T/L3, ⊖, ⊕1, ⊕2, B1, B2, U/T1, V/T2, W/T3	M4	13.3 (1.5)	14 (2.1)	
		⊖				
21P5	1.5/2	R/L1, S/L2, T/L3, ⊖, ⊕1, ⊕2, B1, B2, U/T1, V/T2, W/T3	M4	13.3 (1.5)	14 (2.1)	
		⊖				
22P2	3	R/L1, S/L2, T/L3, ⊖, ⊕1, ⊕2, B1, B2, U/T1, V/T2, W/T3	M4	13.3 (1.5)	12 (3.3)	
		⊖				
23P7	5	R/L1, S/L2, T/L3, ⊖, ⊕1, ⊕2, B1, B2, U/T1, V/T2, W/T3	M4	13.3 (1.5)	10 (5.3)	
		⊖				
25P5	7.5	R/L1, S/L2, T/L3, ⊖, ⊕1, ⊕2, B1, B2, U/T1, V/T2, W/T3	M4	13.3 (1.5)	10 (5.3)	
		⊖				
27P5	10	R/L1, S/L2, T/L3, ⊖, ⊕1, ⊕2, B1, B2, U/T1, V/T2, W/T3	M5	22.1 (2.5)	8 (8)	
		⊖				
2011	15	R/L1, S/L2, T/L3, ⊖, ⊕1, ⊕2, B1, B2, U/T1, V/T2, W/T3	M5	22.1 (2.5)	6 (13.3)	
		⊖				
2015	20	R/L1, S/L2, T/L3, ⊖, ⊕1, ⊕2, U/T1, V/T2, W/T3	M6	44.3 (5.0)	4 (21.2)	
		B1, B2	M5	22.1 (2.5)	6 (13.3)	
		⊖	M6	44.3 (5.0)	6 (13.3)	
2018	25	R/L1, S/L2, T/L3, ⊖, ⊕1, ⊕2, U/T1, V/T2, W/T3	M8	88.5 (10.0)	2 (33.6)	
		B1, B2	M5	22.1 (2.5)	6 (13.3)	
		⊖	M6	44.3 (5.0)	4 (21.2)	
2022	30	R/L1, S/L2, T/L3, ⊖, ⊕1, U/T1, V/T2, W/T3, R1/L11, S1/L21, T1/L31	M8	88.5 (10.0)	1 (42.4)	
		⊕3	M6	45.1 (5.1)	4 (21.2)	
		⊖	M8	88.5 (10.0)	4 (21.2)	
2030	40	R/L1, S/L2, T/L3, ⊖, ⊕1 U/T1, V/T2, W/T3, R1/L11, S1/L21, T1/L31	M8	88.5 (10.0)	1/0 (53.5)	
		⊕3	M6	45.1 (5.1)	4 (21.2)	
		⊖	M8	88.5 (10.0)	2 (38)	

2.2 Wiring Main Circuit Terminals

Drive Model CIMR-P7U□-107	Nominal Hp	Terminal Symbol	Terminal Screws	Clamping Torque lb. in. (N·m)	Recommended Wire Size AWG (mm ²)	Wire Type
2037	50	R/L1, S/L2, T/L3, ⊖, ⊕1 U/T1, V/T2, W/T3, R1/L11, S1/L21, T1/L31	M10	199 (22.5)	4/0 (100)	600 VAC UL Approved vinyl-sheathed or equivalent
		⊕3	M8	88.5 (10.0)	4 (22)	
		⊖	M10	203.6 (23)	2/0 (67.4)	
		r/l1, s/l2	M4	12.4 (1.4)	14 (2.1)	
2045	60	R/L1, S/L2, T/L3, ⊖, ⊕1 U/T1, V/T2, W/T3, R1/L11, S1/L21, T1/L31	M10	199 (22.5)	300 (152)	
		⊕3	M8	88.5 (10.0)	4 (21.2)	
		⊖	M10	199 (22.5)	3/0 (85)	
		r/l1, s/l2	M4	12.4 (1.4)	14 (2.1)	
2055	75	R/L1, S/L2, T/L3, ⊖, ⊕1	M12	347 (39.2)	1/0 X 2P (53.5 X 2P)	
		U/T1, V/T2, W/T3, R1/L11, S1/L21, T1/L31	M10	199 (22.5)	1/0 X 2P (53.5 X 2P)	
		⊕3	M8	88.5 (10.0)	2/0 (67.4)	
		⊖	M10	199 (22.5)	4/0 (107.2)	
		r/l1, s/l2	M4	12.4 (1.4)	14 (2.1)	
2075	75/100	R/L1, S/L2, T/L3, ⊖, ⊕1	M12	347 (39.2)	4/0 X 2P (80 X 2P)	
		U/T1, V/T2, W/T3, R1/L11, S1/L21, T1/L31	M10	199 (22.5)	3/0 X 2P (85 X 2P)	
		⊕3	M8	88.5 (10.0)	2/0 (67.4)	
		⊖	M10	199 (22.5)	2/0 X 2P (67.4 X 2P)	
		r/l1, s/l2	M4	12.4 (1.4)	14 (2.1)	
2090	125	R/L1, S/L2, T/L3, ⊖, ⊕1	M12	347 (39.2)	250 x2P (127 x2P)	
		U/T1, V/T2, W/T3, R1/L11, S1/L21, T1/L31	M12	347 (39.2)	4/0 X 2P (107.2 X 2P)	
		⊕3	M8	88.5 (10.0)	2/0 (67.4)	
		⊖	M12	347 (39.2)	2/0 X 2P (67.4 X 2P)	
		r/l1, s/l2	M4	12.4 (1.4)	14 (2.1)	
2110	150	R/L1, S/L2, T/L3, ⊖, ⊕1	M12	347 (39.2)	300 X 2P (152 X 2P)	
		U/T1, V/T2, W/T3, R1/L11, S1/L21, T1/L31	M12	347 (39.2)	300 X 2P 152 X 2P	
		⊕3	M8	88.5 (10.0)	2/0 (67.4)	
		⊖	M12	347 (39.2)	4/0 X 2P (107.2 X 2P)	
		r/l1, s/l2	M4	12.4 (1.4)	16 (1.25)	

* Use 75°C copper wire or equivalent

Table 2.2 480 VAC Wire Sizes and Connector Specifications

Drive Model CIMR-P7U□-107	Nominal Hp	Terminal Symbol	Terminal Screws	Clamping Torque lb. in. (N·m)	Recommended Wire Size AWG (mm ²)	Wire Type
40P4	0.5/0.75	R/L1, S/L2, T/L3, ⊖, ⊕1, ⊕2, B1, B2, U/T1, V/T2, W/T3	M4	13.3 (1.5)	14 (2.1)	600 VAC UL Approved vinyl-sheathed or equivalent
		⊕				
40P7	1	R/L1, S/L2, T/L3, ⊖, ⊕1, ⊕2, B1, B2, U/T1, V/T2, W/T3	M4	13.3 (1.5)	14 (2.1)	
		⊕				
41P5	1.5/2	R/L1, S/L2, T/L3, ⊖, ⊕1, ⊕2, B1, B2, U/T1, V/T2, W/T3	M4	13.3 (1.5)	14 (2.1)	
		⊕				
42P2	3	R/L1, S/L2, T/L3, ⊖, ⊕1, ⊕2, B1, B2, U/T1, V/T2, W/T3	M4	13.3 (1.5)	14 (2)	
		⊕				
43P7	5	R/L1, S/L2, T/L3, ⊖, ⊕1, ⊕2, B1, B2, U/T1, V/T2, W/T3	M4	13.3 (1.5)	14 (2.1)	
		⊕			14 (2.1)	
45P5	7.5	R/L1, S/L2, T/L3, ⊖, ⊕1, ⊕2, B1, B2, U/T1, V/T2, W/T3	M4	13.3 (1.5)	12 (3.5)	
		⊕			14 (2)	
47P5	10	R/L1, S/L2, T/L3, ⊖, ⊕1, ⊕2, B1, B2, U/T1, V/T2, W/T3	M4	13.3 (1.5)	10 (5.5)	
		⊕			12 (3.5)	
49P0/4011	15/20	R/L1, S/L2, T/L3, ⊖, ⊕1, ⊕2, B1, B2, U/T1, V/T2, W/T3	M5	22.1 (2.5)	8 (8)	
		⊕			10 (5.5)	
4015	25	R/L1, S/L2, T/L3, ⊖, ⊕1, ⊕2, B1, B2, U/T1, V/T2, W/T3	M5	22.1 (2.5)	8 (8)	
		⊕				
4018	30	R/L1, S/L2, T/L3, ⊖, ⊕1, ⊕3, U/T1, V/T2, W/T3,	M6	44.3 (5.0)	6 (13.3)	
		B1, B2	M5	21.1 (2.5)	8 (8)	
		⊕	M6	44.3 (5.0)	6 (13.3)	
4024/4030	40/50	R/L1, S/L2, T/L3, ⊖, ⊕1, ⊕3, U/T1, V/T2, W/T3, R1/ L11, S1/L21, T1/L31	M6	44.3 (5.0)	3 (26.7)	
		⊕	M8	88.5 (10.0)	6 (13.3)	
4037	60	R/L1, S/L2, T/L3, ⊖, ⊕1, U/T1, V/T2, W/T3, R1/L11, S1/L21, T1/L31	M8	88.5 (10.0)	2 (33.6)	
		⊕3	M6	44.3 (5.0)	4 (21.2)	
		⊕	M8	88.5 (10.0)	4 (21.2)	
4045	75	R/L1, S/L2, T/L3, ⊖, ⊕1, U/T1, V/T2, W/T3, R1/L11, S1/L21, T1/L31	M8	88.5 (10.0)	2 (33.6)	
		⊕3	M6	44.3 (5.0)	4 (21.2)	
		⊕	M8	88.5 (10.0)	4 (21.2)	

2.2 Wiring Main Circuit Terminals

Drive Model CIMR-P7U□-107	Nominal Hp	Terminal Symbol	Terminal Screws	Clamping Torque lb. in. (N·m)	Recommended Wire Size AWG (mm ²)	Wire Type
4055	100	R/L1, S/L2, T/L3, ⊖, ⊕1, U/T1, V/T2, W/T3, R1/L11, S1/L21, T1/L31	M8	88.5 (10.0)	2/0 (33.6)	600 VAC UL Approved vinyl-sheathed or equivalent
		⊕3	M6	44.3 (5.0)	4 (21.2)	
		⊖	M8	88.5 (10.0)	1 (42.4)	
4075	125	R/L1, S/L2, T/L3, ⊖, ⊕1	M12	347 (39.2)	4/0 (107.2)	
		U/T1, V/T2, W/T3, R1/L11, S1/L21, T1/L31	M10	199 (22.5)	3/0 (85)	
		⊕3	M8	88.5 (10.0)	4/0 (107.2)	
		⊖	M12	347 (39.2)	1/0 (53.5)	
		r/l1, ⌀200/l2200, ⌀400/l2400	M4	12.4 (1.4)	14 (2.1)	
4090	150	R/L1, S/L2, T/L3, ⊖, ⊕1	M12	347 (39.2)	250 (127)	
		U/T1, V/T2, W/T3, R1/L11, S1/L21, T1/L31	M10	199 (22.5)	4/0 (107.2)	
		⊕3	M8	88.5 (10.0)	4/0 (107.2)	
		⊖	M12	347 (39.2)	2/0 (67.4)	
		r/l1, ⌀200/l2200, ⌀400/l2400	M4	12.4 (1.4)	14 (2.1)	
4110	200	R/L1, S/L2, T/L3, ⊖, ⊕1	M12	347 (39.2)	2/0 X 2P (67.4 X 2P)	
		U/T1, V/T2, W/T3, R1/L11, S1/L21, T1/L31	M12	347 (39.2)	1/0 X 2P (53.5 X 2P)	
		⊕3	M8	88.5 (10.0)	2/0 (67.4)	
		⊖	M12	347 (39.2)	4/0 (107.2)	
		r/l1, ⌀200/l2200, ⌀400/l2400	M4	12.4 (1.4)	14 (2.1)	
4160	250	R/L1, S/L2, T/L3, ⊖, ⊕1	M12	347 (39.2)	4/0 X 2P (107.2 X 2P)	
		U/T1, V/T2, W/T3, R1/L11, S1/L21, T1/L31	M12	347 (39.2)	3/0 X 2P (85 X 2P)	
		⊕3	M8	88.5 (10.0)	2/0 (67.4)	
		⊖	M12	347 (39.2)	1/0 X 2P (53.5 X 2P)	
		r/l1, ⌀200/l2200, ⌀400/l2400	M4	12.4 (1.4)	14 (2.1)	

Drive Model CIMR-P7U□-107	Nominal Hp	Terminal Symbol	Terminal Screws	Clamping Torque lb. in. (N·m)	Recommended Wire Size AWG (mm ²)	Wire Type
4185	300/350	R/L1, S/L2, T/L3, ⊖, ⊕1	M8	88.5 (10.0)	300 X 2P (152 X 2P)	600 VAC UL Approved vinyl-sheathed or equivalent
		U/T1, V/T2, W/T3, R1/L11, S1/L21, T1/L33	M8	88.5 (10.0)	300 X 2P (152 X 2P)	
		⊕3	M8	88.5 (10.0)	2/0 (67.4)	
		⊖	M16	867.4 (98.0)	3/0 X 2P (85 X 2P)	
		r/l1, Ⓜ200/l2,200, Ⓜ400/l2,400	M4	12.4 (1.4)	14 (2.1)	
4220	400/450	R/L1, S/L2, T/L3, ⊖, ⊕1	M8	88.5 (10.0)	500 X 2P (253 X 2P)	
		U/T1, V/T2, W/T3, R1/L11, S1/L21, T1/L33	M8	88.5 (10.0)	400 X 2P (203 X 2P)	
		⊕3	M8	88.5 (10.0)	2/0 (67.4)	
		⊖	M16	867.4 (98.0)	250 X 2P (127 X 2P)	
		r/l1, Ⓜ200/l2,200, Ⓜ400/l2,400	M4	12.4 (1.4)	14 (2.1)	
4300	500+	R/L1, S/L2, T/L3, ⊖, ⊕1	M8	88.5 (10.0)	700 X 2P (355 X 2P)	
		U/T1, V/T2, W/T3, R1/L11, S1/L21, T1/L33	M8	88.5 (10.0)	600 X 2P (304 X 2P)	
		⊕3	M8	88.5 (10.0)	2/0 (67.4)	
		⊖	M8	867.4 (98.0)	400 X 2P (203 X 2P)	
		r/l1, Ⓜ200/l2,200, Ⓜ400/l2,400	M16	12.4 (1.4)	14 (2.1)	

* Use 75°C copper wire or equivalent

IMPORTANT

Determine the wire size for the main circuit so that line voltage drop is within 2% of the rated voltage. Line voltage drop is calculated as follows:

$$\text{Line voltage drop (V)} = \sqrt{3} \times \text{wire resistance (W/km)} \times \text{wire length (m)} \times \text{current (A)} \times 10^{-3}$$

⚠ WARNING

Prior to removing any protective cover or wiring any part of the iQpump drive, remove all power sources, including main input power and control circuit power. Wait a minimum of 5 minutes after power removal, before removing any cover. The charge lamp located within the iQpump drive should be off prior to working inside. Even if the charge lamp is off, one must measure the AC input, output, and DC Bus potential to insure safe levels prior to resuming work. Failure to adhere to this warning may result in personal injury or death.

2.2 Wiring Main Circuit Terminals

◆ Main Circuit Terminal Functions

Main circuit terminal functions are summarized according to terminal symbols in [Table 2.3](#). Wire the terminals correctly for the desired purpose.

Table 2.3 Main Circuit Terminal Functions (208-240 VAC and 480 VAC)

Purpose	Terminal Designation	Model: CIMR-P7U□-107	
		208-240 VAC	480 VAC
Main circuit power input	R/L1, S/L2, T/L3	20P4 to 2110	40P4 to 4300
	R1/L11, S1/L21, T1/L31	2022 to 2110	4030 to 4300
Drive outputs	U/T1, V/T2, W/T3	20P4 to 2110	40P4 to 4300
DC power input	⊕1, ⊖	20P4 to 2110	40P4 to 4300
DC reactor connection	⊕1, ⊕2	20P4 to 2018	40P4 to 4018
Ground	⊕	20P4 to 2110	40P4 to 4300

◆ Main Circuit Configurations 208-240 VAC

The 208-240 VAC main circuit configurations of the iQpump drive are shown in [Table 2.4](#).

Table 2.4 iQpump Drive Main Circuit Configurations

208-240 VAC	
<p>CIMR-___20P4 to 2018 (1/2 Hp to 25 Hp)</p> <p>Note 1</p>	<p>CIMR-___2022 and 2030 (30 Hp to 40Hp)</p> <p>Notes 1 & 3</p>
<p>CIMR-___2037 to 2110 (50 Hp to 150 Hp)</p> <p>Notes 1 & 3</p>	<p>—</p>
<p>Note: 1. Input fuses or molded case circuit breakers are required for proper branch circuit protection for all iQpump drives. Failure to use recommended fuses/circuit breakers (See Appendix E) may result in damage to the wiring, iQpump drive and/or personal injury.</p> <p>2. Control power is supplied internally from the main circuit DC power supply for all iQpump drives.</p> <p>3. Consult your Yaskawa representative before using 12-pulse rectification.</p>	

◆ Main Circuit Configurations 480 VAC

The 480 VAC main circuit configurations of the iQpump drive are shown in [Table 2.5](#).

Table 2.5 iQpump Drive Main Circuit Configurations

480 VAC	
<p style="text-align: center;">CIMR-___40P4 to 4018 (1/2 Hp to 30 Hp)</p> <p>Note 1</p>	<p style="text-align: center;">CIMR-___4024 to 4055 (40 Hp to 100 Hp)</p> <p>Notes 1 & 3</p>
<p style="text-align: center;">CIMR-___4075 to 4160 and CIMR-___4185 to 4300 (125 Hp to 500 Hp)</p> <p>Notes 1 & 3</p>	<p style="text-align: center;">—</p>
<p>Note: 1. Input fuses or molded case circuit breakers are required for proper branch circuit protection for all iQpump drives. Failure to use recommended fuses/circuit breakers (see Appendix E) may result in damage to the wiring, iQpump drive and/or personal injury.</p> <p>2. Control power is supplied internally from the main circuit DC power supply for all iQpump drives.</p> <p>3. Consult your Yaskawa representative before using 12-pulse rectification.</p>	

■ Cable Length Between iQpump Drive and Motor

The iQpump should be installed as close as possible to the motor to minimize the length of load side power cable needed between the iQpump drive and the motor.

If the cable between the iQpump drive and the motor is long, the high-frequency leakage current will increase, causing the iQpump drive output current to increase as well. This may affect peripheral devices. To prevent this, reduce the cable length whenever possible, or if necessary, adjust the carrier frequency (set in C6-02) as shown in [Table 2.6](#).

The line side power cables, load side power cables and the control wiring should all be run in a separate conduit. Careful attention to this recommended design practice will avoid many potential motor and iQpump drive related problems.

Table 2.6 Motor Cable Length vs. Carrier Frequency (C6-02)

Motor Cable Length	328ft. (100m) maximum	More than 328ft. (100m)
Carrier Frequency	10kHz maximum	5kHz maximum

(See the limitations on carrier frequency, based on iQpump drive capacity and model number in [Appendix B](#)).

■ Ground Wiring

Observe the following precautions when connecting the ground wire:

1. 208-240 VAC iQpump drives should have a ground connection with resistance of less than 100Ω.
2. 480 VAC iQpump drives should have a ground connection with resistance of less than 10Ω.
3. Do not share the ground wire with other devices, such as motors or large-current electrical equipment.
4. Always use a ground wire that complies with technical standards on electrical equipment and minimize the length of the ground wire. Leakage current flows through the iQpump drive. Therefore, if the distance between the ground rod and the ground terminal is too long, potential on the ground terminal of the iQpump drive will become unstable.
5. When using more than one iQpump drive, be careful not to loop the ground wire. See [Figure 2.4](#).

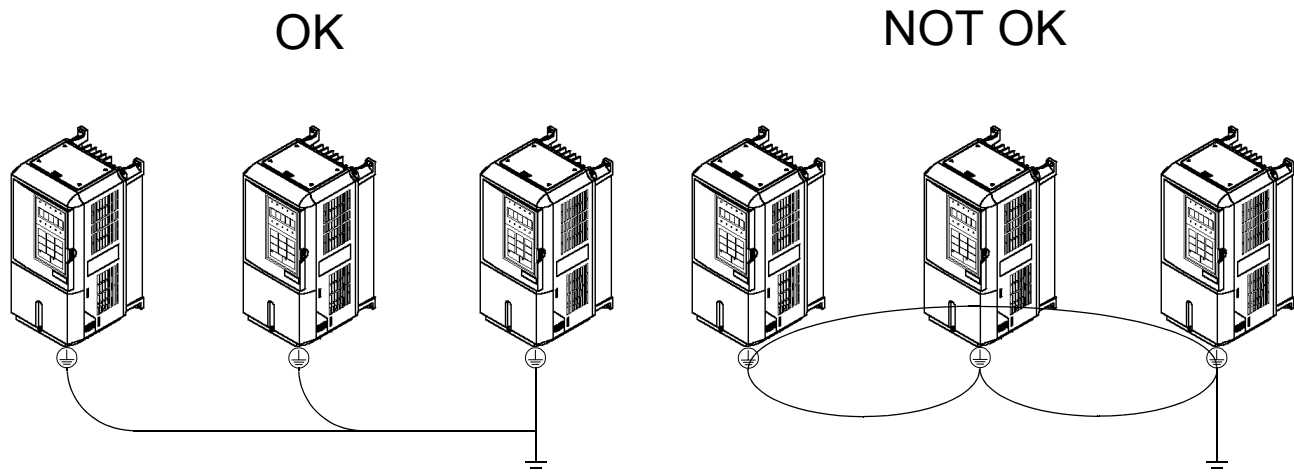

Figure 2.2 Ground Wiring Examples

■ Control Circuit Ground Terminals

The removable iQpump drive control terminal card provides two ground terminals (marked TB3 and TB4) to accept the control wire shield connection. The control wire shield should be connected on this end only, the opposite end should be isolated with electrical tape.

IMPORTANT | Grounding of the iQpump enclosure and motor is required for proper system operation.

2.3 Control Wiring

◆ Control Circuit Wire Sizes

The auto mode setpoint (speed command) field wiring connection is made to iQpump drive terminals A1 or A2 (signal positive), AC (signal common) and G (shield). Keep this lead length as short as possible to maintain signal quality. Insulated twisted shielded pair wire (2 conductor # 18 ga, Belden 8760 or equivalent) is required. Do not run these wires in the same conduit as other AC power or control wires. The shield must be connected on this end only, stub and isolate the other end. The A2 signal employed is 4 to 20 mA with parameter H3-08 set for “2: 4 - 20 mA.” For 0 to 10 Vdc, parameter H3-08 is set for “0: 0 - 10 Vdc” and the iQpump control board DIP switch S1-2 must be in the OFF position. (See [Figure 2.4](#)).

For remote operation, keep the length of the control wiring to 50m or less. Separate the control wiring from high-power lines (input power, motor leads or relay sequence circuits) to reduce noise induction from peripheral devices.

When setting speed commands (frequency references) from an external speed potentiometer (and not from the Digital Operator), use shielded twisted-pair wires and ground the shield to terminal E(G), as shown in [Figure 2.3](#). Terminal numbers and wire sizes are shown in [Table 2.7](#).

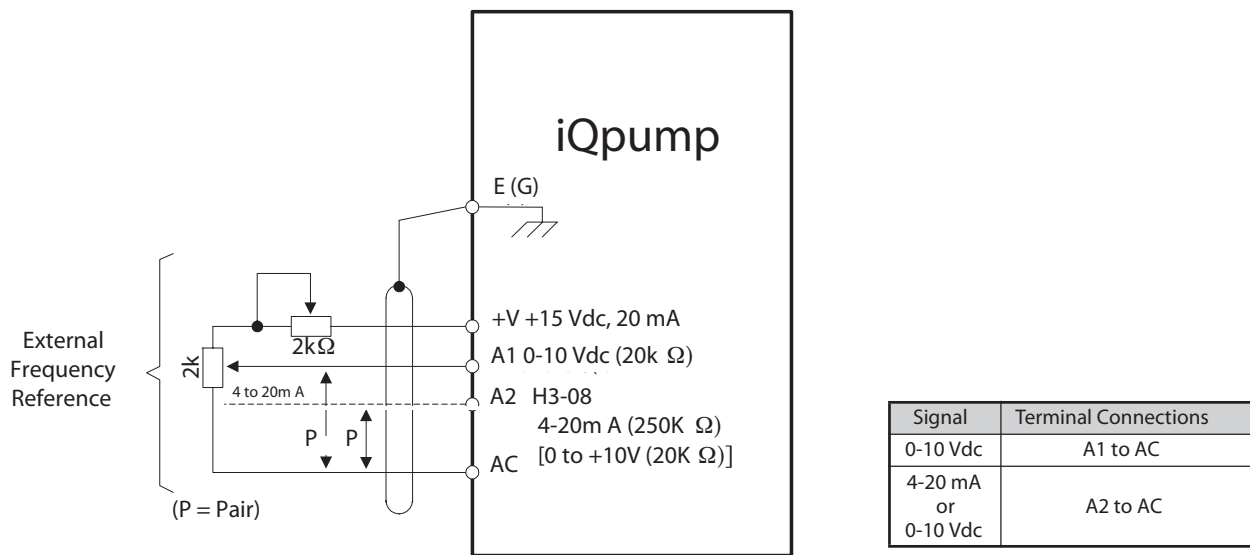

Figure 2.3 Analog Input Terminal Configuration

Table 2.7 Terminal Numbers and Wire Sizes (Same for all iQpump Drives)

Terminals	Terminal Screws	Tightening Torque lb-in (N•m)	Possible Wire Sizes AWG (mm ²)	Recommended Wire Size AWG (mm ²)	Wire Type
S1, S2, S3, S4, S5, S6, S7 SN, SC, SP, +V, A1, A2, AC, MI, M2, M3, M4, MA, MB, MC, FM, AC, AM, R+, R-, S+, S-, IG	Phoenix type *3	4.2 to 5.3 (0.5 to 0.6)	Stranded wire: 26 to 16 (0.14 to 1.5)	18 (0.75)	<ul style="list-style-type: none"> Shielded, twisted-pair wire*1 Shielded, polyethylene-covered, vinyl sheath cable
E(G)	M3.5	7.0 to 8.8 (0.8 to 1.0)	20 to 14 (0.5 to 2*2)	12 (1.25)	

*1. Use shielded twisted-pair cables to input an external speed command.

*2. Yaskawa recommends using straight solderless terminals on digital inputs to simplify wiring and improve reliability.

*3. Yaskawa recommends using a thin-slot screwdriver with a 3.5 mm blade width.

■ Wiring Checks

After all wiring is completed, perform the following checks:

1. Is all wiring correct?
2. Have all wire clippings, screws or other foreign material been removed from the iQpump drive enclosure?
3. Are all terminal screws tight?

◆ Control Circuit Terminal Functions

The factory default functions of the control circuit terminals for 2-wire control are shown in [Table 2.8](#).

Table 2.8 Control Circuit Terminals

Type	No.	Signal Name	Description	Signal Level	
Digital input signals	S1	Forward run/stop command	Forward run when CLOSED; stopped when OPEN.	24 Vdc, 8 mA Photocoupler isolation	
	S2	Not used.	Not used.		
	S3	External fault input	Fault when CLOSED.		Multi-function digital inputs Functions set by H1-01 to H1-05.
	S4	Fault reset	Reset when CLOSED		
	S5	Multi-step SP1	Multi-step SP1 frequency reference when CLOSED.		
	S6	Hand Mode	Hand Mode when CLOSED.		
	S7	Pre-Charge	Pre-Charge function disabled when CLOSED.		
	SN	Digital input common	Refer to Table 2.10 for connection details.		
	SC				
	SP				
Analog input signals	+V	+15Vdc power supply	+15Vdc power supply for analog inputs or transmitters	+15Vdc (Max. current: 20 mA)	
	A1	Analog input or Speed Command	0 to +10Vdc/100%	0 to +10 V(20 kΩ)	
	A2	Multi-function analog input (PI Feedback)	4 to 20 mA/100% 0 to +10Vdc/100% (H3-0)	Function set by H3-09.	4 to 20 mA(250Ω) 0 to +10 V(20kΩ)
	AC	Analog common	—	—	
	E(G)	Shield wire, optional ground line connection point	—	—	
Digital output signals	M1	Pump 2 Control (N.O. contact)	CLOSED during operation	Multi-function digital output Function set by H2-01.	Dry contacts Contact capacity: 1 A max. at 250Vac 1 A max. at 30Vdc
	M2				
	M3	Pump 3 Control (N.O. contact)	CLOSED when local control	Multi-function digital output Function set by H2-02.	
	M4				
	MA	Fault output signal (SPDT)	MA/MC: CLOSED during fault condition MB/MC: OPEN during fault condition		
	MB				
MC					
Analog output signals	FM	Multi-function analog output	(output frequency) 0 to +10Vdc/100% frequency	Multi-function analog monitor 1 Function set by H4-01	0 to +10Vdc max. ±5% 2 mA max.
	AC	Analog common	—		
	AM	Multi-function analog output	(output current) 0 to +10Vdc/100% Drive's rated output current	Multi-function analog monitor 2 Function set by H4-04	
RS-485/422	R+	Modbus communication input	For 2-wire RS-485, jumper R+ and S+ and jumper R- and S-.		Differential input, PHC isolation
	R-				
	S+	Modbus communication output			Differential input, PHC isolation
	S-				
	IG	Signal common			—

◆ DIP Switch S1

DIP Switch S1 is described in this section. The functions of DIP switch S1 are shown in [Table 2.9](#).

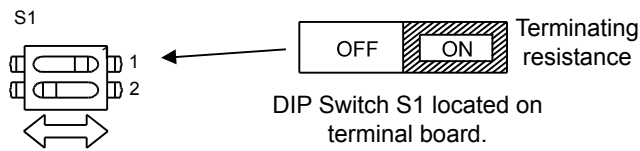
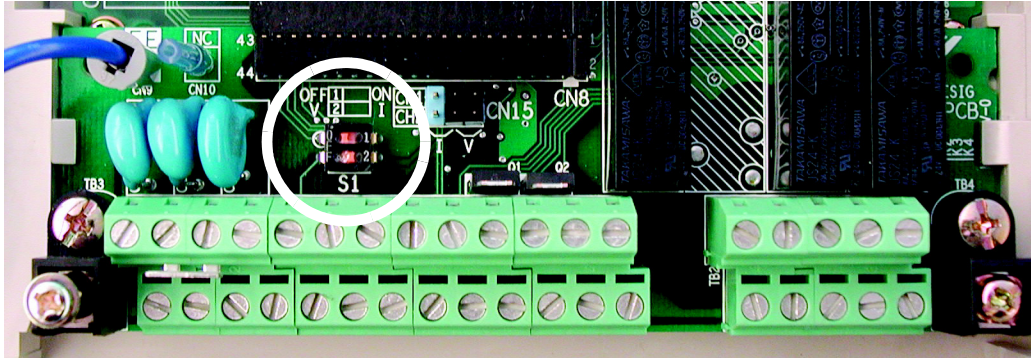

Figure 2.4 DIP Switch S1 Location

Table 2.9 DIP Switch S1

Name	Function	Setting
S1-1	RS-485 and RS-422 terminating resistance	OFF: No terminating resistance (<i>factory default</i>) ON: Terminating resistance of 110Ω
S1-2	Input method for analog input A2	OFF: 0-10 Vdc (internal resistance: 20KΩ) ON: 4-20mA (internal resistance: 250Ω) (<i>factory default</i>)

◆ Shunt Connector CN15

The shunt connector CN15 is described in this section. Shunt connector along with parameters H4-07 and H4-08 select the signal range of the analog output terminals FM and AM.

Shunt connector CN15 is only available when the optional Terminal Card with the 4-20mA Analog Output Monitor is installed (Model No. ETC618120). See [Chapter 7 Maintenance](#), for installation of the optional Terminal Card.

The function of various shunt connector CN15 configurations is shown in [Table 2.10](#).

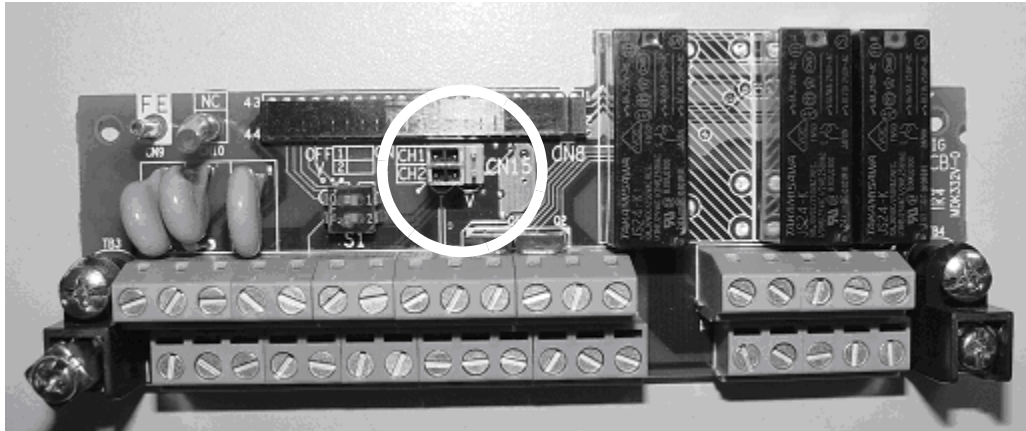

Figure 2.5 Shunt Connector CN15 Location

Table 2.10 Shunt Connector CN15 Configuration Options

CN15	Analog Output Monitor Configurations
	Voltage Output (0-10 Vdc) for terminals FM-AC (CH1) and AM-AC (CH2)
	Current Output (4-20mA) for terminals FM-AC (CH1) and AM-AC (CH2)
	Voltage Output (0-10 Vdc) for terminals FM-AC (CH1) Current Output (4-20mA) for terminals AM-AC (CH2)
	Current Output (4-20mA) for terminals FM-AC (CH1) Voltage Output (0-10 Vdc) for terminals AM-AC (CH2)

The software configuration for the analog output monitor signal type is listed below:

Parameter No.	Modbus Address	Parameter Name Digital Operator Display	Description	Setting Range	Factory Setting	Menu Location
H4-07	0423H	Terminal FM Signal Level Selection AO Level Select1	0: 0 - 10 Vdc 2: 4-20 mA*	0 or 2	0	Programming
H4-08	0424H	Terminal AM Signal Level Selection AO Level Select2	0: 0 - 10 Vdc 2: 4-20 mA* * An analog output of 4 - 20 mA cannot be used with the standard terminal board. Therefore an optional terminal board (with shunt connector CN15) is needed.	0 or 2	0	Programming

◆ Sinking/Sourcing Mode

The input terminal logic can be switched between sinking mode (0V common) and sourcing mode (+24V common) by using the terminals SN, SC, and SP. An external power supply can also be connected, providing more freedom in signal input methods.

Table 2.11 Sinking/Sourcing Mode and Input Signals

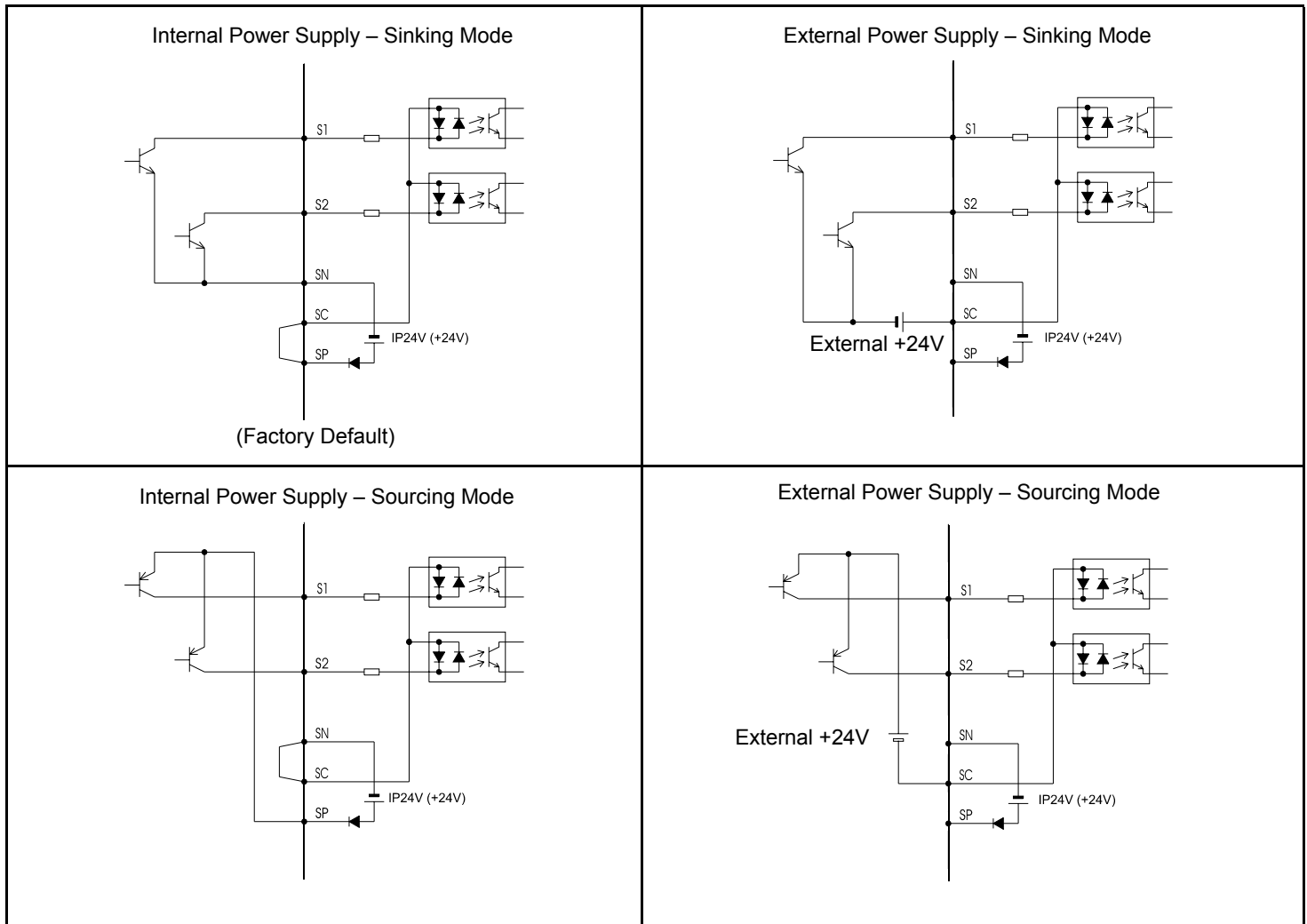

◆ Control Circuit Terminal Connections

■ iQpump Factory Default

Connections to iQpump drive terminals for the default factory settings are shown in *Figure 2.6*.

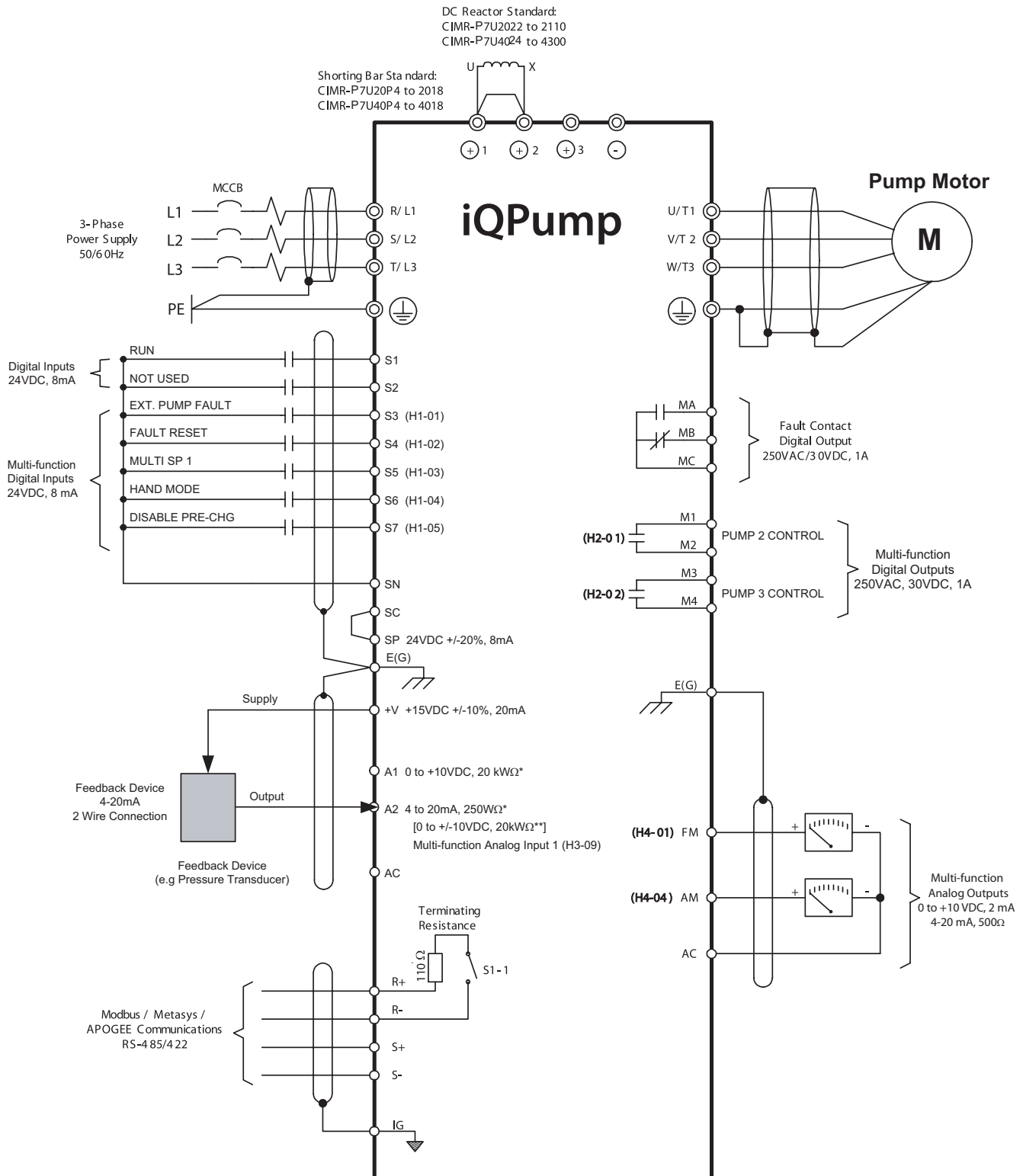

Figure 2.6 Default Terminal Connections

◆ Control Circuit Wiring Precautions

Observe the following precautions when wiring control circuits:

1. Separate control wiring from power/motor wiring (terminals R/L1, S/L2, T/L3, U/T1, V/T2, W/T3, \ominus , $\oplus 1$, $\oplus 2$, and $\oplus 3$) and other high-power lines.
2. Separate wiring for control circuit terminals MA, MB, MC, M1, M2, M3, and M4 (digital outputs) from wiring to other control circuit terminals.
3. If using an optional external power supply, ensure it is a UL Listed Class 2 power supply source.
4. Use twisted-pair or shielded twisted-pair cables for control circuits to prevent operating faults. Prepare cable ends as shown in [Figure 2.7](#).
5. Connect the shield wire to terminal E(G).
6. Insulate the shield with tape to prevent contact with other signal lines and equipment.

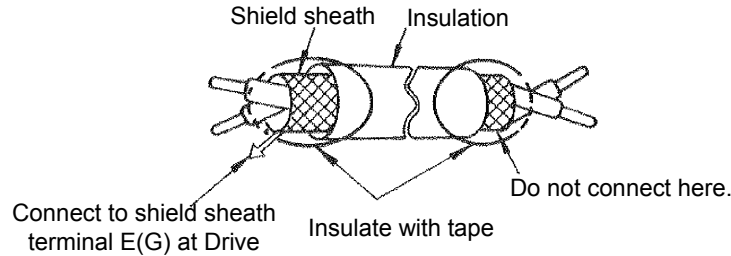

Figure 2.7 Preparing the Termination of Shielded Twisted-pair Cables

■ Duplex Pump System Wiring

Connections to the Multi-function Digital Outputs for a Duplex Pump system.

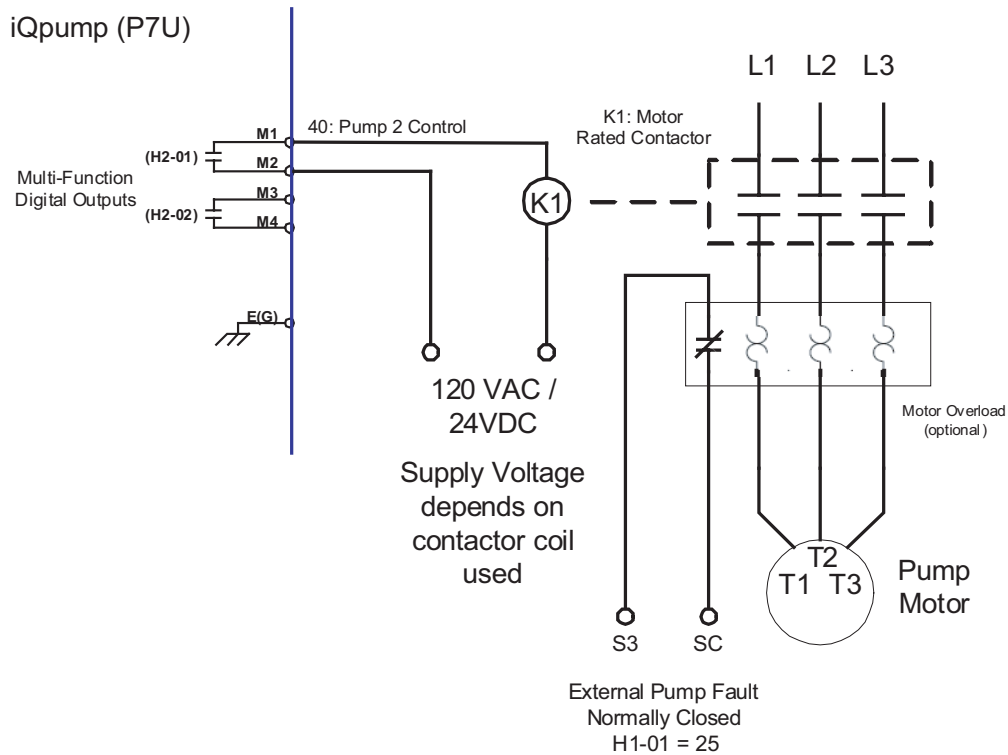

Figure 2.8 Duplex Pump System Wiring

■ Triplex Pump System Wiring

Connections to the Multi-function Digital Outputs for a Triplex Pump system.

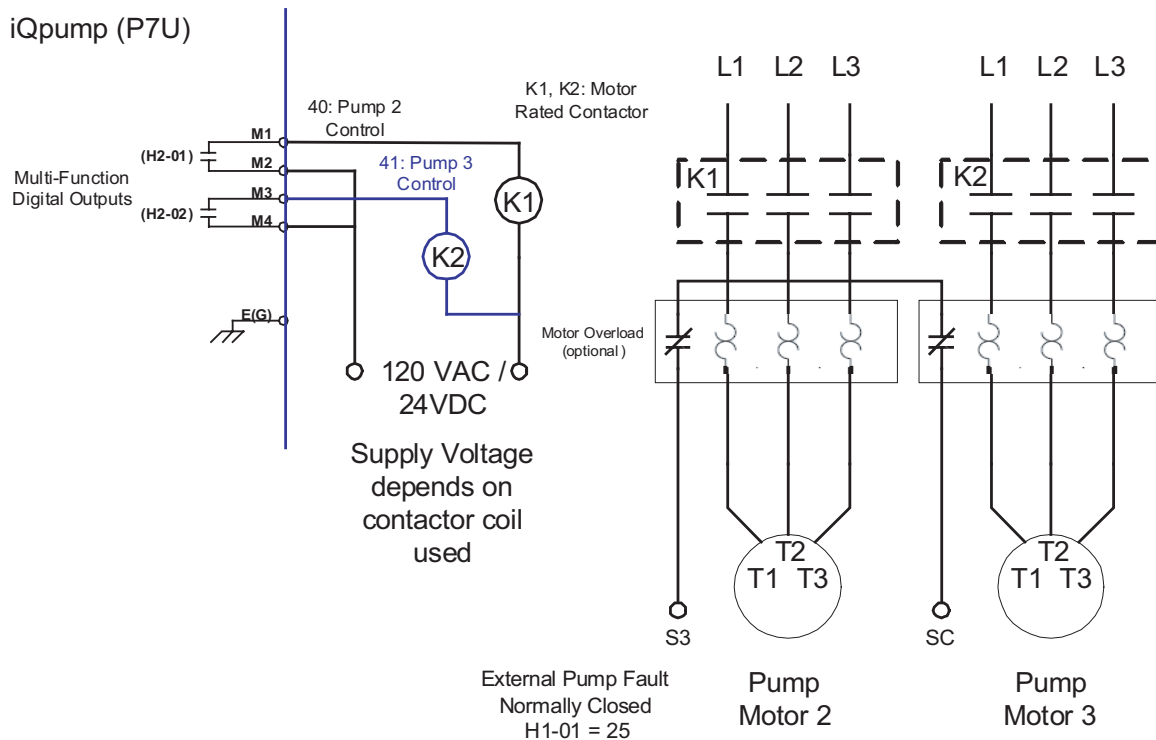

Figure 2.9 Triplex Pump System Wiring

■ Duplex Pump System with Motor Starter Wiring

Connections to the Multi-function Digital Outputs for a Duplex Pump System using Motor Starters.

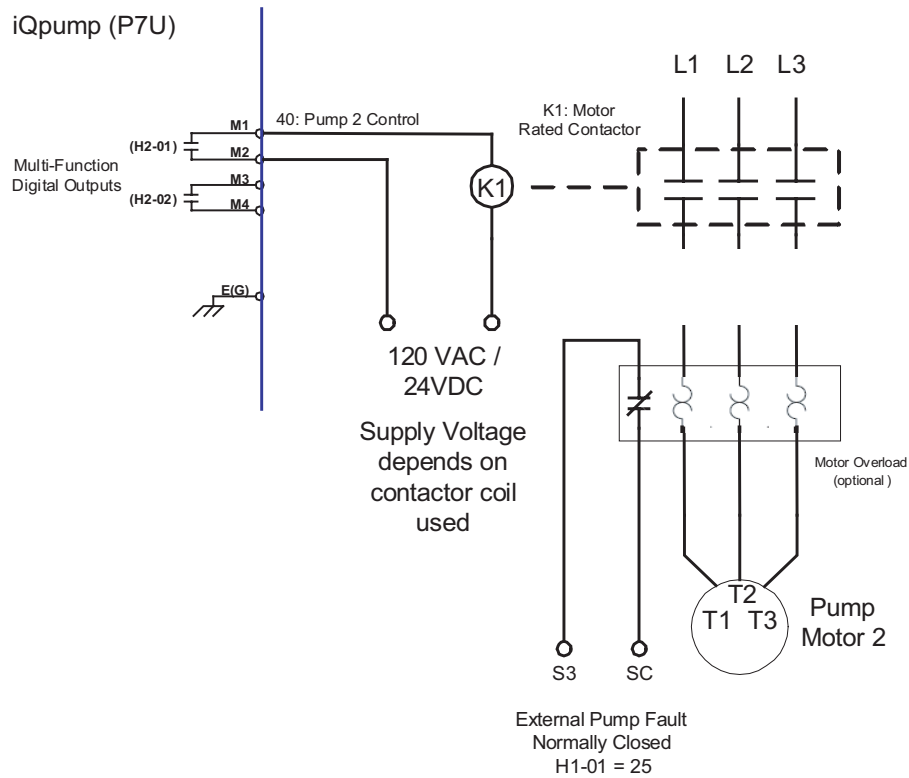

Figure 2.10 Duplex Pump System with Motor Starter Wiring

■ Triplex Pump System with Motor Starters Wiring

Wiring diagram shows connections to the Multi-Function Digital Outputs for a Triplex Pump System using Motor Starters.

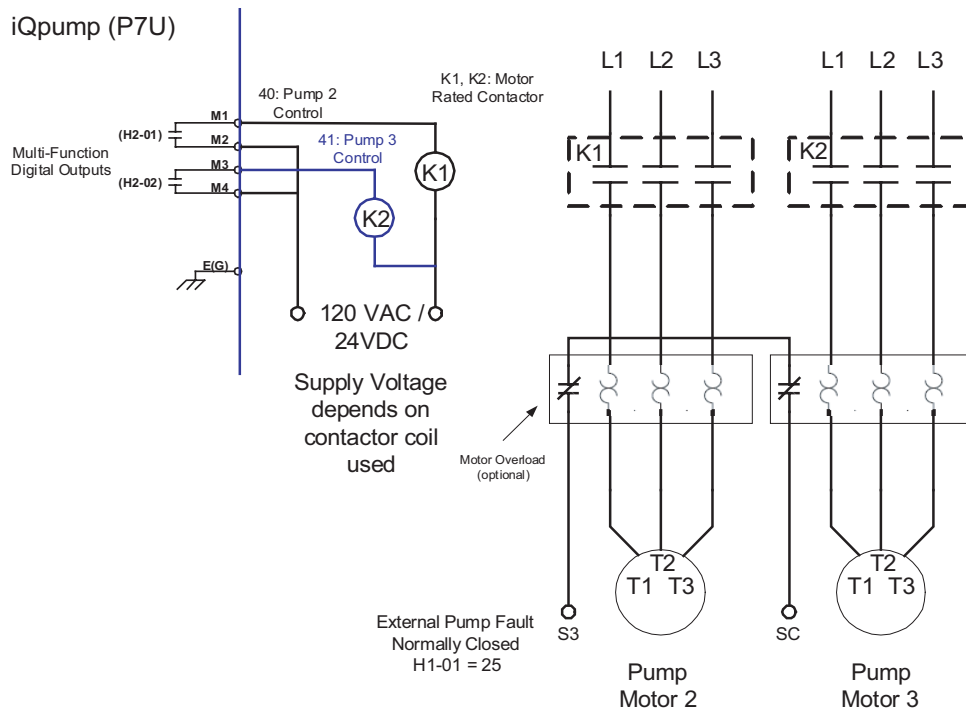

Figure 2.11 Triplex Pump System with Motor Starters

■ Feedback Device (3-Wire)

Connection of a 3-Wire 0 ~ 10 Vdc Feedback Device (H3-08 = 0)

In order to use a 4 ~ 20 mA feedback device, parameter H3-08 Terminal A2 Signal has to be programmed to 2.

Note: In order to use a 0 ~ 10V feedback device parameter for terminal A2, the parameter H3-08 Terminal A2 Signal has to be programmed to 0 and dip switch S1-2 has to be set to OFF for the iQpump to accept a 0 ~ 10 Vdc signal.

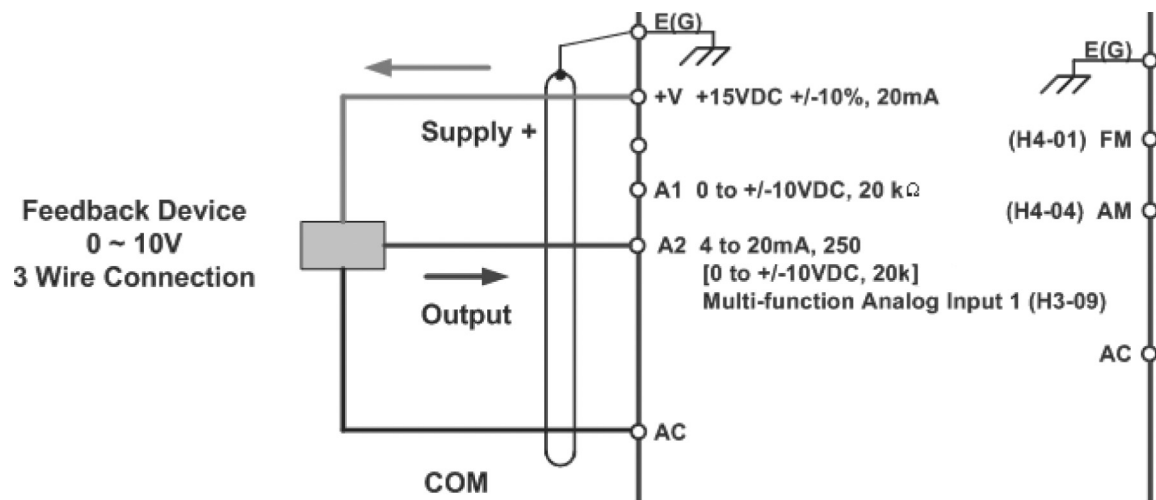
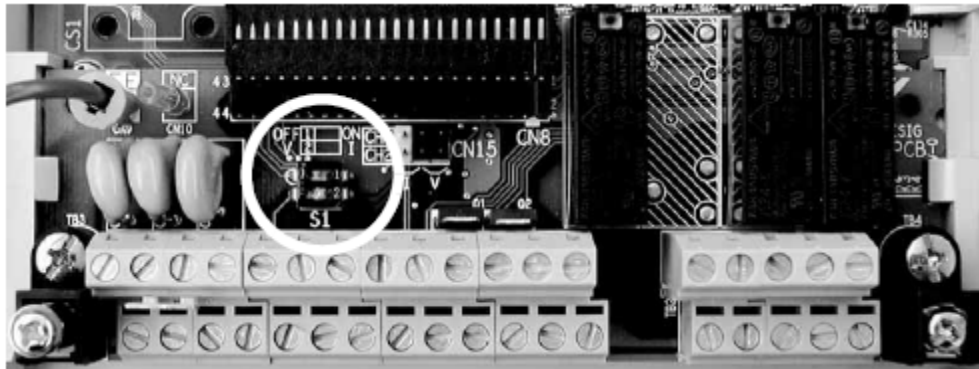

Figure 2.12 Feedback Device (3-Wire) Connection

2.3 Control Wiring

THIS PAGE INTENTIONALLY LEFT BLANK.



Digital Operator

This chapter describes the displays and functions of the Digital Operator.

3.1 Digital Operator Display	52
3.2 Digital Operator Keys	53
3.3 Drive Mode Indicators	54
3.4 Drive Main Menu	55
3.5 Pump Quick Setup Menu (-QUICK-)	60
3.6 Programming Menu (-ADV-)	61
3.7 Example of Changing a Parameter.	63

3.1 Digital Operator Display

The Digital Operator is used for programming, operating, and monitoring iQpump drive operation. By default, the iQ Pump Drive will not run unless the digital operator is securely attached to the iQpump drive.

The various items included on the Digital Operator are described below.

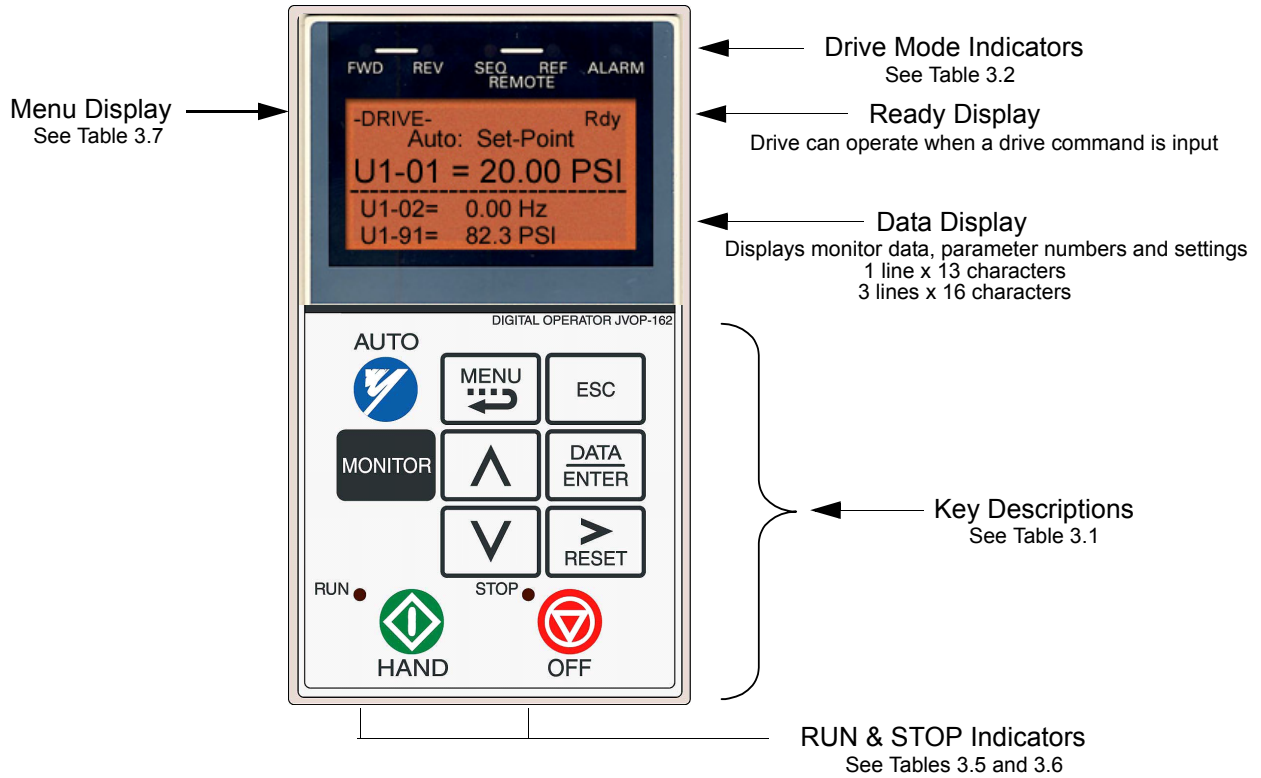

Figure 3.1 Digital Operator Component Names and Functions











⚠ WARNING

The digital operator can be used to operate (start) the iQpump drive. Incorrect programming and/or improper key selection on the digital operator may result in the iQpump drive starting unexpectedly. Prior to making any adjustments with the digital operator, insure that all personnel are clear from the iQpump drive, motor, and machine. Also, insure that all covers, couplings, pulleys, shaft keys, etc. are secure.

3.2 Digital Operator Keys

The names and functions of the Digital Operator Keys are described in [Table 3.1](#).

Table 3.1 Digital Operator Keys

Key	Name	Function
	AUTO Key	<ul style="list-style-type: none"> Pressing the AUTO key will put the Drive in the “Auto” mode. In the “Auto” mode, the Drive will be capable of starting/stopping depending on the setting of parameter “b1-02” (Run Command Selection). In the “Auto” mode, the Drive setpoint will depend on the setting of parameter “b1-01” (Reference Source). If the OFF key is pressed, the “Auto” mode frequency reference will continue to be displayed on the keypad. Pressing the AUTO key will start the Drive if the run command is already closed. If the Drive is running in the “Auto” mode and the OFF key is pressed, the Drive will stop. If the run command remains closed, pressing the AUTO key will restart the Drive. While the Drive is running, the run command can be opened to stop and closed to restart without taking the Drive out of the “Auto” mode.
	MENU Key	Scrolls through the five main menus.
	ESCAPE Key	Returns to the previous display, before the DATA/ENTER key was pressed.
	MONITOR Key	Selects the monitor mode from the Operation (-DRIVE-), Quick Setting (-QUICK-), Programming (-ADV-) and Modified Constants (-VERIFY-) menus + A.TUNE.
	INCREASE Key	Increases parameter numbers and set values. Used to move to the next item or data value.
	DECREASE Key	Decreases parameter numbers and set values. Used to move to the previous item or data value.
	SHIFT/RESET Key	Selects the digit to be changed. The selected digit will blink. Also resets the Drive when a fault has occurred, if the fault condition doesn't exist anymore and there isn't an active RUN command.
	DATA/ENTER Key	Pressed to enter menus and parameters as well as to set values.
	HAND Key	<ul style="list-style-type: none"> Pressing the HAND key will put the Drive in the “Hand” mode and start the Drive. In the “Hand” mode, the drive speed command will depend on the setting of parameter “p5-01” (Hand Mode Source and p5-02 Hand Reference). If the OFF key is pressed, the “Hand” mode speed command will continue to be displayed on the keypad.
	OFF Key	Stops Drive operation, following the stopping method as programmed in parameter b1-03.

3.3 Drive Mode Indicators

The definitions of the iQpump drive mode indicators are shown in [Table 3.2](#).

Table 3.2 iQpump Drive Mode Indicators

Indicator	Definition
FWD	Lit when a forward run command is input and when Drive is in “Hand” Mode.
AUTO SEQ	Lit when set up for remote run command. See Table 3.3 .
AUTO REF	Lit when set up for remote speed command. See Table 3.4 .
ALARM	Lit when a fault has occurred. Flashes when an alarm has occurred.

◆ AUTO Sequence (SEQ) Indicator

The status of the AUTO “Sequence” (SEQ) indicator is shown in [Table 3.3](#). This indicator is always “Off” when the iQpump drive is in the “Hand” mode. When the iQpump drive is in the “Auto” mode, the SEQ indicator status is dependent on the setting of parameter “b1-02” (Run Command Selection).

Table 3.3 AUTO Sequence (SEQ) Indicator

Indicator Status	Hand Mode	Auto Mode
On	N/A	Parameter “b1-02” (Run Command Selection) is set to terminal strip, communications, or an option board as indicated below: b1-02 = 1 (Terminals) = 2 (Communications) = 3 (Option PCB)
Off		Parameter “b1-02” (Run Command Selection) is set to digital operator as indicated below: b1-02 = 0 (Operator)

The status of the AUTO “Reference” (REF) indicator is shown in [Table 3.4](#). This indicator is always “Off” when the iQpump drive is in the “Hand” mode. When the iQpump drive is in the “Auto” mode, the REF indicator status is dependent on the setting of parameter “b1-01” (Frequency Reference Selection).

Table 3.4 AUTO Reference (REF) Indicator

Indicator Status	Hand Mode	Auto Mode
On	N/A	Parameter “b1-01” (Frequency Reference Selection) is set to terminal strip, communications, or an option board as indicated below: b1-01 = 1 (Terminals) = 2 (Communications) = 3 (Option PCB)
Off		Parameter “b1-01” (Frequency Reference Selection) is set to digital operator as indicated below: b1-01 = 0 (Operator)

◆ Run Indicator

The status of the “RUN” indicator is shown in [Table 3.5](#) when the iQpump drive is in either the “Hand” or “Auto” mode.

Table 3.5 RUN Indicator

Indicator Status	Condition
On	Drive is running
Blinking	Drive is decelerating to a stop
Off	Drive is stopped

◆ Stop Indicator

The status of the “STOP” indicator is shown in [Table 3.6](#) when the iQpump drive is in either the “Hand” or “Auto” mode.

Table 3.6 STOP Indicator

Indicator Status	Condition
On	Drive is decelerating to a stop or stopped
Blinking	Drive is in a run condition but the frequency reference is zero or Drive is running in “Auto” mode and OFF has been pressed
Off	Drive is running

3.4 Drive Main Menu

The iQpump drive’s parameters and monitoring functions are organized into menu groups that make it easier to read and set parameters. The iQpump drive is equipped with five menu selections. The five selections and their primary functions are shown in [Table 3.7](#) and are directly available by pressing the MENU key.

Table 3.7 iQpump Drive Menu Selections

Main Menu	Primary Function(s)
Operation - DRIVE -	The Drive can be run in this menu. Use this menu for monitoring values such as frequency reference or output current, displaying fault history or displaying the fault traces.
Pump Quick Setup - QUICK -	The Drive can be programmed in this menu. Use this menu to set/read the most commonly used parameters.
Programming - ADV -	The Drive can be programmed in this menu. Use this menu to set/read every parameter.
Modified Constants - VERIFY -	The Drive can be programmed in this menu. Use this menu to set/read the parameters that have been modified from their factory default settings.
Auto-Tuning - A.TUNE -	The Drive can be programmed in this menu. Use this menu to auto-tune the Drive in order to optimize motor control as well as utilize the bi-directional speed search feature.

◆ Pump Quick Setup Main Menu Structure

The menu selection display will appear when the MENU key is pressed from a monitor or setting display. While viewing the menu selection display, press the MENU key repeatedly to scroll between the menu selections.

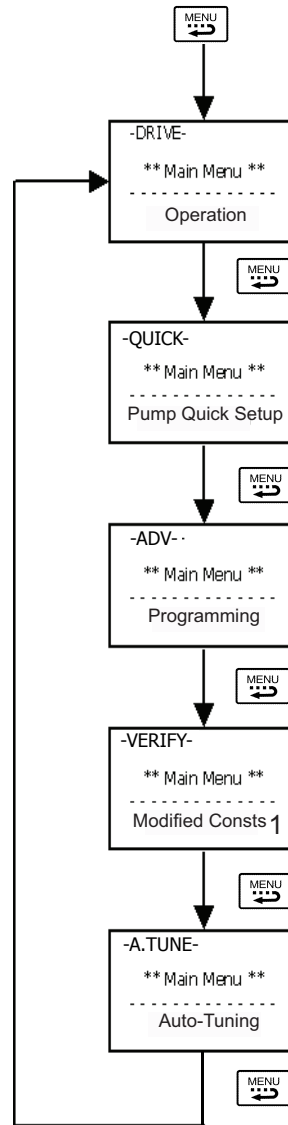

Figure 3.2 Main Menu Structure

Press the DATA/ENTER key to enter the desired menu selection.

¹ Modified Consts = Modified Parameters

◆ Operation Menu (-DRIVE-)

This menu is used for setting a speed command or monitoring values such as output frequency and output current. It is also used for displaying the fault history and the fault traces. The iQpump drive must be in this menu in order to run, see parameter b1-08.

IMPORTANT

- Leaving the iQpump drive in a menu other than the Operation Menu, will prohibit the iQpump drive from running. While running, if the iQpump drive is in a menu other than "Operation" and the run command is removed and re-applied, the iQpump drive will stop and will not start until the Operation Menu is selected unless b1-08 = 1.

■ U1 Monitor List

Follow the key operations below (*Figure 3.3*) to access the Operation Menu:

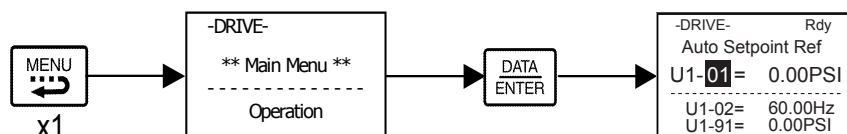

Figure 3.3 U1 Monitor List Access Procedure



Use  and  keys to scroll through the U1 Monitor Parameter List. See *Appendix A* for functional description.

Table 3.8 U1 Monitor Parameter List

Monitor	Parameter Name Digital Operator Display	Monitor	Parameter Name Digital Operator Display
U1-01	Auto Setpoint Reference Auto: Setpoint	U1-24	PI Feedback Value PI Feedback
U1-02	Output Frequency Output Freq	U1-28	CPU Number CPU ID
U1-03	Output Current Output Current	U1-29	kWh kWh Lo 4 Digits
U1-06	Output Voltage Output Voltage	U1-30	MWh kWh Hi 5 Digits
U1-07	DC Bus Voltage DC Bus Voltage	U1-34	First Parameter Causing an OPE OPE Detected
U1-08	Output Power Output kWatts	U1-36	PI Input PI Input
U1-10	Input Terminal Status Input Term Sts	U1-37	PI Output PI Output
U1-11	Output Terminal Status Output Term Sts	U1-38	PI Setpoint PI Setpoint
U1-12	Drive Operation Status Int Ctl Sts 1	U1-39	Memobus Communication Error Code Transmit Err
U1-13	Cumulative Operation Time Elapsed Time	U1-40	Heatsink Cooling Fan Operation Time FAN Elapsed Time
U1-14	Software Number FLASH ID	U1-90	Pump Setpoint Reference Pump Setpoint
U1-15	Terminal A1 Input Voltage Term A1 Level	U1-91	Pump Feedback Pump Feedback
U1-16	Terminal A2 Input Voltage Term A2 level	U1-92	Pump Status Pump Status
U1-18	Motor Secondary Current (Iq) Mot SEC Current	U1-93	Total Setpoint Compensation Total SP Comp.
U1-20	Output Frequency After Soft Start SFS Output	U1-94	Motor Speed Motor Speed

■ U2 Fault Trace List

After viewing the “Monitor” parameter list, in order to view the “Fault Trace” parameter list, follow the key operations below *Figure 3.4*.

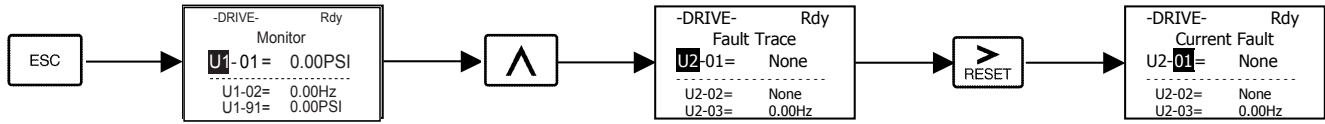

Figure 3.4 U2 Fault Trace List Access Procedure

Use and keys to scroll through the U2 Fault Trace Parameter List.

Table 3.9 U2 Fault Trace Parameter List

Fault Trace Parameters	
U2-01	Current Fault
U2-02	Last Fault
U2-03	Frequency Ref
U2-04	Output Freq
U2-05	Output Current
U2-07	Output Voltage
U2-08	DC Bus Voltage
U2-09	Output kWatts
U2-11	Input Term Sts
U2-12	Output Term Sts
U2-13	AC Drive Status
U2-14	Elapsed Time

■ U3 Fault History List

After viewing the “Fault Trace” parameter list, in order to view the “Fault History” parameter list, follow the key operations below (Figure 3.5.)

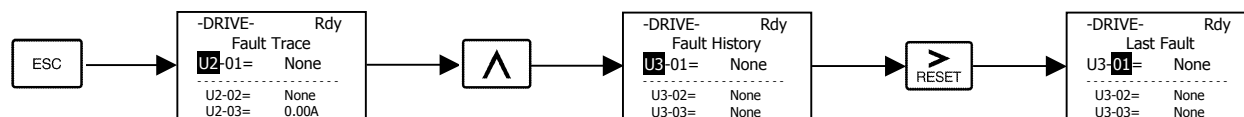

Figure 3.5 U3 Fault History Access Procedure

Use and keys to scroll through the U3 Fault History Parameter List.

Table 3.10 U3 Fault History Parameter List

Fault History Parameters	
U3-01	Last Fault
U3-02	Fault Message 2
U3-03	Fault Message 3
U3-04	Fault Message 4
U3-05	Elapsed Time 1
U3-06	Elapsed Time 2
U3-07	Elapsed Time 3
U3-08	Elapsed Time 4
U3-09	Fault Message 5
U3-10	Fault Message 6
U3-11	Fault Message 7
U3-12	Fault Message 8
U3-13	Fault Message 9
U3-14	Fault Message 10
U3-15	Elapsed Time 5
U3-16	Elapsed Time 6
U3-17	Elapsed Time 7
U3-18	Elapsed Time 8
U3-19	Elapsed Time 9
U3-20	Elapsed Time 10

3.5 Pump Quick Setup Menu (-QUICK-) <0032>

This menu is used to set/read the most commonly used parameters in the iQpump drive. Follow the key operations below (Figure 3.6) to access the Pump Quick Setup Menu

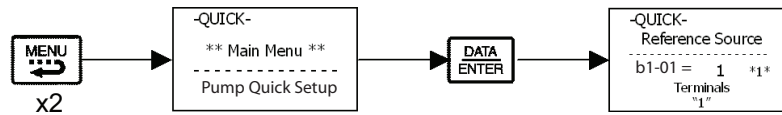

Figure 3.6 Pump Quick Setup Parameter Access Procedure



Use  and  keys to scroll through the Quick Setting Parameter List.

Table 3.11 Pump Quick Setup Parameter List

Parameter Number	Parameter Name
E2-01	Motor Rated Current
E2-04	Number of Motor Poles
b1-02	Run Command Selection
b1-01	Frequency Reference Selection
P1-02	System Units
P1-03	Feedback Device Scaling
b5-12	PI Feedback Ref Missing Detection Selection
b5-13	PI Feedback Loss Detection Level
b5-14	PI Feedback Loss Detection Time
P1-04	Start Level
P1-05	Start Level Delay Time
P2-01	Sleep Level Type
P2-02	Sleep Level
P2-03	Sleep Delay Time
P1-06	Minimum Pump Frequency
C1-01	Acceleration Time 1
C1-02	Deceleration Time 1
P5-01	Hand Mode Reference Source
P5-02	Hand Reference
P1-11	Pump Protection Level
P1-12	Pump Protection Time
P1-14	Prime Loss Level
P4-09	Loss of Prime Maximum Restart Time After Fault
L5-01	Number of Auto Restart Attempts
L5-03	Maximum Restart Time After Fault
P4-08	Protection Fault Auto Restart Enable
P4-07	Feedback Fault Auto Restart Enable
P1-07	Low Feedback Level
P1-08	Low Feedback Level Fault Delay Time
P1-09	High Feedback Level
P1-10	High Feedback Level Fault Delay Time
P2-10	Maximum Setpoint Compensation
P4-01	Pre-Charge Level
P4-02	Pre-Charge Frequency
P4-03	Pre-Charge Time
P4-04	Thrust Bearing Acceleration Time
P4-05	Thrust Bearing Frequency
P4-06	Thrust Bearing Deceleration Time
P4-10	Auto Mode Operator Run Power Down Storage

3.6 Programming Menu (-ADV-)

This menu is used to set/read every parameter in the iQpump drive. Follow the key operations below (*Figure 3.7*) to access the Programming Menu.

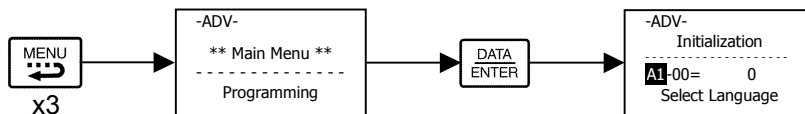

Figure 3.7 Programming Menu Access Procedure



Use , , and  keys to scroll through the Programming Parameter Group List. For complete parameter listing see [Appendix A](#).

Table 3.12 Programming Parameter Group List

Parameter Group Functions	
A1	Initialization
b1	Sequence
b2	DC Braking
b3	Speed Search
b4	Delay Timers
b5	PI Control
b8	Energy Saving
C1	Accel/Decel
C2	S-Curve Acc/Dec
C4	Torque Comp
C6	Carrier Freq
d1	Preset Reference
d2	Reference Limits
d3	Jump Frequencies
E1	V/F Pattern
E2	Motor Setup
F6	Com OPT Setup
H1	Digital Inputs
H2	Digital Outputs
H3	Analog Inputs
H4	Analog Outputs
H5	Serial Com Setup
L1	Motor Overload
L2	PwrLoss Ridethru
L3	Stall Prevention
L4	Ref Detection
L5	Fault Restart
L6	Torque Detection
L8	Hdwe Protection
n1	Hunting Prev
n3	High Slip
o1	Monitor Select
o2	Key Selections
o3	COPY Function
P1	Pump Basic
P2	Pump Protection
P3	Pump Multiplex

◆ **Modified Constants Menu (-VERIFY-)**

This menu is used to set/read the parameters that have been modified from their original factory default settings. Follow the key operations below (Figure 3.8) to access the Modified Constants Parameter Menu.

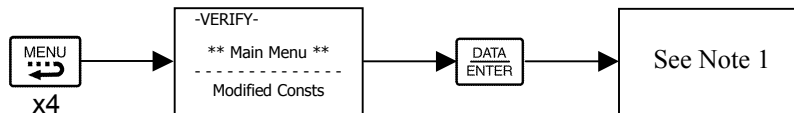

Figure 3.8 Modified Constants Menu Access Procedure

Note: If there are not any parameters that have been modified from their original factory default settings, then the display will state “None Modified.” Otherwise, use the “increase” and “decrease” keys to scroll through the “Modified Constants” list.

◆ **Auto-Tuning Menu (-A.TUNE-)**

This menu is used to auto-tune the iQpump drive in order to optimize motor control as well as utilize the bi-directional speed search feature. Follow the key operations below (Figure 3.9) to access the Auto-Tuning Menu.

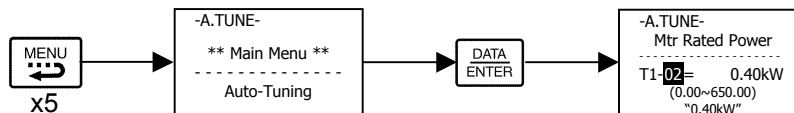

Figure 3.9 Auto-Tuning Menu Access Procedure



Use  and  keys to scroll through the Auto-Tuning Parameter List.

Table 3.13 Auto-Tuning Parameter List

Auto-Tuning Parameters
T1-02 Mtr Rated Power
T1-04 Rated Current

3.7 Example of Changing a Parameter

Table 3.14 provides an example of how to change parameter “C1-02” (Deceleration Time 1) from 30 seconds to 40 seconds.

Table 3.14 Changing a Parameter in the Programming Menu

Step Number	Digital Operator Display	Description
1	<pre> -DRIVE- Rdy Auto: Set-Point Ref U1-01 = 0.0PSI ----- U1-02 = 0.00Hz U1-91 = 0.00PSI </pre>	The Drive is first powered up.
2	<pre> -DRIVE- ** Main Menu ** ----- Operation </pre>	Press the MENU key to scroll to “Operation” menu.
3	<pre> -QUICK- ** Main Menu ** ----- Pump Quick Setup </pre>	Press the MENU key to scroll to “Pump Quick Setup” menu.
4	<pre> -ADV- ** Main Menu ** ----- Programming </pre>	Press the MENU key to scroll to “Programming” menu.
5	<pre> -ADV- Initialization ----- A1-01= 0 Select Language </pre>	Press the DATA/ENTER key to enter “Programming” menu.
6	<pre> -ADV- Accel/Decel ----- C1-01= 1.0sec Accel Time 1 </pre>	Press the INCREASE key until C1-01 (Accel/Decel) is displayed.
7	<pre> -ADV- Accel Time 1 ----- C1-01= 30.0sec (0.0~6000.0) "30.0sec" </pre>	Press the SHIFT/RESET key to move flashing digit to the right.
8	<pre> -ADV- Decel Time 1 ----- C1-02= 30.0sec (0.0~6000.0) "30.0sec" </pre>	Press the INCREASE key to display C1-02 (Decel Time 1).
9	<pre> -ADV- Decel Time 1 ----- C1-02= 030.0sec (0.0~6000.0) "30.0sec" </pre>	Press the DATA/ENTER key to access setting display.
10	<pre> -ADV- Decel Time 1 ----- C1-02= 0030.0sec (0.0~6000.0) "30.0sec" </pre>	Press the SHIFT/RESET key to move the flashing digit to the right.

3.7 Example of Changing a Parameter

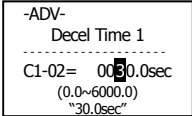
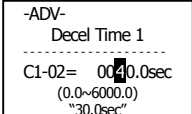
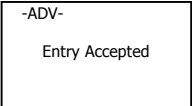
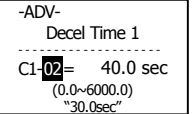
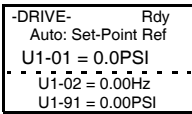
Step Number	Digital Operator Display	Description
11		Press the SHIFT/RESET key to move the flashing digit to the right.
12		Press the INCREASE key to increase the set data.
13		Press the DATA/ENTER key to enter the set data. "Entry Accepted" is displayed for 1.0 sec after the data setting has been confirmed.
14		The monitor display for C1-02 returns.
16		Press the MONITOR key on the HOA keypad to enter "Operation" menu.



Start Up

This chapter describes the procedures to prepare the iQpump drive for start up and the procedures to conduct an iQpump drive start up.

4.1 Start Up	66
4.2 iQpump Drive Start Up Procedures	69
4.3 Pump System Start/Stop	73
4.4 Pump Basics	75
4.5 Use Feedback Level to Start iQpump Controller	77
4.6 Low Feedback Level Alarm and Fault Setup	79
4.7 High Feedback Level Alarm and Fault Setup	81
4.8 Feedback Loss Detection	83
4.9 Basic Pump Protection	84

4.1 Start Up

In order to provide the most reliable iQpump drive available and to avoid any extra costs related to loss or reduction of warranty coverage, an authorized Yaskawa service representative should complete this start up procedure. Please complete the following checklist and maintain it in a secure location as technical service personnel may request information from this checklist.

◆ Drive Start Up Preparation

Date: _____

Start Up Person:

Company Name: _____

Start Up Location: _____

Sales Order #: _____

Serial #: _____

Printed Name: _____

Drive Location: _____

Phone #: _____

Signature: _____

Owners Representative:

Printed Name: _____

Phone #: _____

Company: _____

Signature: _____

Step

- 1. The iQpump drive is thoroughly tested at the factory. The start up person should verify that the iQpump drive is free of shipping and installation damage. Shipping damage is not covered by the Yaskawa warranty. Claims must be filed with the shipping company as soon as possible for any potential recovery via insurance.
- 2. Review the iQpump (P7U) User Manual (TM.iQp.01) shipped with the iQpump drive.
- 3. Verify that the model number and voltage ratings in the purchase order match the nameplate data for each unit.
- 4. Location of the iQpump drive is important to achieve proper performance and normal operating life. The unit should be installed in an area where it is protected from:
 - Direct sunlight, rain or moisture
 - Corrosive gases or liquids
 - Vibration, airborne dust or metallic particles
- 5. Ensure the iQpump drive is on a vertical surface with adequate space for air circulation (4.75" above and below, 1.2" on each side). Refer to **Figure 1.5**.
- 6. Verify that the proper branch circuit protection is installed in front of the iQpump drive. Refer to **Appendix E Peripheral Devices** for proper input fuse or circuit breaker sizing.
- 7. Avoid running input and output wiring in the same conduit.
- 8. Avoid routing power wiring near equipment sensitive to electrical noise.

- 9. Never allow wire leads to touch metal surfaces. Short-circuit may result.
- 10. Never connect AC main power output terminals U/T1, U/T2 and W/T3.
- 11. Never connect power factor correction capacitors or noise filters to the iQpump drive output.
- 12. Use 600 Vac vinyl-sheathed wire or equivalent. Wire size should be determined considering voltage drop of leads.
Line voltage drop (V) = $\sqrt{3}$ x wire resistance (Ω /km) x wire length (m) x current (A) x 10^{-3}
- 13. It is recommended that the motor lead length not exceed 164 feet (50 meters) and motor wiring be run in a separate conduit from the power wiring. If lead length must exceed this distance, reduce the carrier frequency (see **Figure 2.6**) and consult Yaskawa toll free at 1-800-YASKAWA (927-5292) for other motor protection measures.
- 14. Signal and control leads must be separated from main circuit leads (R/L1, S/L2, T/L3, U/T1, V/T2, W/T3).
- 15. Determine proper wire size for power and motor leads. Refer to **Table 2.1** and **Table 2.2** for details.
- 16. Review proper ground connections for the iQpump drive. Refer to **Chapter 2** for details. The iQpump drive must be solidly grounded using the main circuit ground terminal. Ground resistance should be less than 100Ω for a 208-240 Vac iQpump drive. Ground resistance should be less than 10Ω for a 480 Vac iQpump drive. Select wire size suitable for the size of terminal screw. Make the length as short as possible.

Never ground the iQpump drive in common with welding machines, motors or other large-current electrical equipment.

Where several iQpump drives are used, ground each iQpump drive directly or daisy-chain to the ground pole(s).
DO NOT FORM A LOOP WITH THE GROUND LEADS. See **Table 2.4**.
- 17. Review terminal functions of signal and control circuits. Refer to **Table 2.8**.
- 18. Verify if any customer safety devices are required (e.g. External Pump Fault).
- 19. Record the following motor nameplate information:

Voltage: _____ Motor Rated Amps: _____
- 20. Verify that the commercial power supply is within the rated iQpump drive input voltage:

Power Supply: _____ VAC Drive Input Voltage: _____ VAC
- 21. Verify that the leads in the 3-Phase electric motor conduit box are configured for the proper voltage.
- 22. Ensure Motor Rated Current is less than or equal to iQpump drive Output Amps. If multiple motors are being used, make sure that the Motor Rated Current sum is less than or equal to iQpump drive Output Amp rating. Please note that if multiple motors are being operated from one iQpump drive, each motor must have its own overload and short circuit protection.
- 23. Wire all necessary power leads to the iQpump drive. **DO NOT CONNECT MOTOR TO iQpump DRIVE YET.**
- 24. Wire all necessary ground wires to the iQpump drive.

4.1 Start Up

- 25. Wire all necessary control wires to the iQpump drive.
- 26. Ensure that the power leads are connected to the R/L1, S/L2 and T/L3 terminals in the iQpump drive.
- 27. Tighten all of the three-phase power and ground connections. Please check that all control and signal terminations are tight.
- 28. Inspect the control circuit connections (including the shield) and determine if a motor “safety circuit” is connected.
If normally closed, these contacts may be wired in series with the **RUN** command contacts, which are between terminals **S1** and **SN** of the iQpump drive. No special programming is required. Refer to **Chapter 2**.

Alternately, these contacts could be wired between terminals **S3** and **SN** as **External Fault Inputs**, and may be either normally closed or normally open contacts.
- 29. Record any other connections to the iQpump drive using the blank terminal connection drawing in Chapter 2 – Electrical Installation (Fig. 2.9) to determine if special programming is required for the following:
 - Multi-function Inputs – refer to **Appendix A**.
 - Multi-function Outputs – refer to **Appendix A**.
 - Multi-function Digital Inputs – refer to **Appendix A**.
 - Multi-function Analog Outputs – refer to **Appendix A**.
 - Serial Communications – refer to **Appendix A**.

THIS COMPLETES THE iQpump DRIVE START UP PREPARATION.

4.2 iQpump Drive Start Up Procedures

1. Confirm that all three phases are present and that the input voltage is correct for the iQpump drive being set up. Measure the voltage on the line side of the iQpump drive's Molded Case Circuit Breaker/disconnect and record below.

Table 4.1

Measurement Location	Voltage (Vac)
L1 – L2	
L2 – L3	
L1 – L3	

WARNING

Use extreme caution when performing measurements as contact with live parts may result in personal injury or death.

2. If voltage level is within iQpump drive Specification (See **Appendix C**), **APPLY POWER** to energize the iQpump drive. The **STOP**, **AUTO SEQ** and **AUTO REF** indicators should be on.
3. **REMOVE POWER** from the iQpump drive. Wait for the Red CHARGE LED (near the power terminals) to go out.

WARNING

The internal capacitor remains charged even after the power supply is turned off. The status indicator LED's and the digital operator display will be extinguished when the DC bus voltage is below 50VDC. To prevent electric shock, wait at least 5 minutes after all indicators are off and measure the DC Bus voltage level to confirm a safe level prior to working on the iQpump drive.

4. Connect the motor leads to the iQpump drive at terminals U/T1, V/T2 and W/T3.
5. **APPLY POWER** to the iQpump drive.
6. Press the **HAND** key once. This puts the iQpump drive in the Hand Mode, allowing run/stop and speed commands (frequency references) by the digital operator. The **AUTO SEQ** and **AUTO REF** indicators turn off. The **FWD** light turns on. The **RUN** light turns on. The **STOP** light is blinking. "Hand Reference" (U1-01) is now displayed on the Digital Operator.
7. Press the **OFF** key.
8. Press the **MENU** key two times. Press the **DATA/ENTER** key once to enter the Pump Quick Setup Menu. Press the **▲** key to display parameter E1-01 "Input Voltage." This parameter selects the nominal input voltage the iQpump drive will receive. To set this parameter for the application. Press the **DATA/ENTER** key once. Use the **▲**, **▼**, and **▶** keys and the **DATA/ENTER** key to set this parameter per the application.

Table 4.2 Input Voltage Setting

Parameter No.	Modbus Address	Parameter Name Digital Operator Display	Description	Setting Range	Factory Setting	Menu Location	Page No.
E1-01	0300H	Input Voltage Setting Input Voltage	Set to the nominal voltage of the incoming line.	155 to 255.0 (240 V) 310 to 510.0 (480 V)	240 V 480 V	Pump Quick Setup	105

Ensure the **DATA/ENTER** key is pressed to enter the selection in the iQpump drive. "Entry Accepted" briefly appears and the display is now no longer flashing.

9. Press the **▲** key once to display E2-01 "Motor Rated FLA." This parameter is the foundation of motor protection. It can be entered when auto-tuning is performed. Set this parameter according to the motor rated current (FLA). Press the **DATA/ENTER** key once. Use the **▲**, **▼**, and **▶** keys to adjust E2-01 to the motor rated full load amps.

4.2 iQpump Drive Start Up Procedures

Table 4.3 Motor Rated Current

Parameter No.	Modbus Address	Parameter Name Digital Operator Display	Description	Setting Range	Factory Setting	Menu Location	Page No.
E2-01	030EH	Motor Rated Current Motor Rated FLA	Set to the motor nameplate full load amps.	10% to 200% of Drive Rated Current	kVA Dependent	Pump Quick Setup	108

Ensure the **DATA/ENTER** key is pressed to enter the value in the iQpump drive. “Entry Accepted” briefly appears and your display is now flashing.

- 10. Press the ESC once. Press DATA/ENTER once. Press ▲ key once to display b1-02 “Run Source.” This parameter selects where the iQpump drive will receive the run command. Press the **DATA/ENTER** key once. Use the ▲ or ▼ keys and the **DATA/ENTER** key to set this parameter for the application.

Table 4.4 Run Command Selections

Parameter No.	Modbus Address	Parameter Name Digital Operator Display	Description	Setting Range	Factory Setting	Menu Location	Page No.
b1-02	0181H	Run Command Selection Run Source	Selects the run command input source. 0: Operator - “Hand” and “Off” keys on digital operator 1: Terminals - Contact Closure on Terminal S1 2: Serial Com - RS-485 terminals R+, R-, S+ and S- 3: Option PCB - Option board connected at 2CN	0 to 3	0	Pump Quick Setup	92

Ensure the **DATA/ENTER** key is pressed to enter the selection in the iQpump drive. “Entry Accepted” briefly appears and the display is now not flashing.

- 11. Press the ▼ key once to display b1-01 “Reference Source.” This parameter selects where the iQpump drive will receive the set-point. Press the **DATA/ENTER** key once. Use the ▲ or ▼ keys and the **DATA/ENTER** key to set this parameter for the application.

Table 4.5 Speed Command Selection

Parameter No.	Modbus Address	Parameter Name Digital Operator Display	Description	Setting Range	Factory Setting	Menu Location	Page No.
b1-01	0180H	Frequency Reference Selection Reference Source	Selects the speed command (frequency reference) input source. 0: Operator - Digital preset speed d1-01 1: Terminals - Analog Input Terminal A1 (or Terminal A2 see parameter H3-13) 2: Serial Com - RS-485 terminals R+, R-, S+ and S- 3: Option PCB - Option board connected at 2CN	0 to 3	0	Pump Quick Setup	89

Ensure the **DATA/ENTER** key is pressed to enter the selection in the iQpump drive. “Entry Accepted” briefly appears and the display is now not flashing.

- 12. Press the ▲ key twice to display b1-03 “Stopping Method.”
This parameter selects the stopping method used when a stop command is given to the iQpump drive.

Table 4.6 Stopping Method Selection

Parameter No.	Modbus Address	Parameter Name Digital Operator Display	Description	Setting Range	Factory Setting	Menu Location	Page No.
b1-03	0182H	Stopping Method Selection Stopping Method	Selects the stopping method when the run command is removed. 0: Ramp to Stop 1: Coast to Stop 2: DC Injection to Stop 3: Coast w/Timer (A new run command is ignored if input before the time in C1-02 expires.)	0 to 3	0	Pump Quick Setup	94

Press the **DATA/ENTER** key once. Use the ▲ or ▼ keys to select the stopping method. Ensure the **DATA/ENTER** key is pressed to enter the selection in the iQpump drive. “Entry Accepted” briefly appears and the display is not flashing.

- 13. Press the **MENU** key once to display “Operation.”
- 14. Press the **DATA/ENTER** key once to display Auto: Set-Point.
- 15. The **STOP** and **FWD** lights are on.
- 16. Press the **DATA/ENTER** key once to enable entering of an Auto Mode Set-Point in U1-01. Use the **▲** and **▼** keys to set a set-point of 10 PSI.
- 17. Press the **AUTO** key once to start the motor and verify correct motor rotation for the application. The **RUN** light turns on and the **STOP** light turns off.
 If the direction of motor rotation is wrong, press the **OFF** key. The **RUN** light turns off and the **STOP** light turns on. **REMOVE POWER** from the iQpump drive. Wait for the Red CHARGE LED (near the power terminals) to go out. When it does, swap the motor wires connected to terminals **U/T1** & **V/T2** in the iQpump drive. Be sure to re-tighten the terminal lugs. **APPLY POWER**.
 To verify the motor rotation is now correct for the application, press the **AUTO** key once to start the motor and turn off the **AUTO SEQ** and **AUTO REF** lights. The **FWD** light turns on and the motor will rotate in the proper direction.
- 18. Press the **MONITOR** key to display the U1 monitors. Use the **▲** and **▼** keys to view Output Current (U1-03), Output Voltage (U1-06), and DC Bus Voltage (U1-07) while running the iQpump drive throughout its entire speed range. Record the following information at each speed:

Table 4.7

Hand Reference (Hz) Monitor U1-01	Output Current (A) Monitor U1-03	Output Voltage (VAC) Monitor U1-06	DC Bus Voltage (VDC) Monitor U1-07
6.0			
10.0			
15.0			
20.0			
25.0			
30.0			
35.0			
40.0			
45.0			
50.0			
55.0			
60.0			

When this table is complete, press the **OFF** key. The iQpump drive will stop and the **FWD** light remains on. This step provides benchmark data for the application from the initial start up.

- 19. Press the **MENU** key once to display “Operation.” Press the **DATA/ENTER** key to display “Hand Reference.”
 If using a remote speed command, press the **AUTO** key so the **AUTO SEQ** and **AUTO REF** indicators are on. This puts the iQpump drive in Auto mode.

THIS COMPLETES THE iQpump DRIVE START UP PROCEDURE.

4.2 iQpump Drive Start Up Procedures

NOTES:

4.3 Pump System Start/Stop

◆ Pump Mode

Table 4.8 Pump Mode

Parameter No.	Modbus Address	Parameter Name Digital Operator Display	Description	Setting Range	Factory Setting	Menu Location	Page No.
P1-01	0600H	Pump Mode Pump Mode	Select type of control operation. 0: Drive Only (Simplex) 1: Drive + 1 Pump 2: Drive + 2 Pumps	0 to 2	0	Pump Quick Setup	—

The iQpump drive can control up to 3 pumps with one pump operating from the iQpump drive and the other two pumps being controlled by the iQpump drive's digital output contacts. The pump mode parameter P1-01 allows the user to select the number of pumps controlled by the iQpump drive.

◆ Auto Mode Start/Stop Selection

Table 4.9 Auto Mode Start/Stop Selection

Parameter No.	Modbus Address	Parameter Name Digital Operator Display	Description	Setting Range	Factory Setting	Menu Location	Page No.
b2-01	0189H	DC Injection Braking Start Frequency DCInj Start Freq	Sets the frequency at which DC injection braking starts when ramp to stop (b1-03 = 0) is selected. If b2-01 < E1-09, DC injection braking starts at E1-09.	0.0 to 10.0	0.5 Hz	Programming	96
b2-02	018AH	DC Injection Braking Current DCInj Current	Selects the DC injection braking current as a percentage of the Drive rated current.	0 to 100	50%	Programming	97
P1-02	0601H	System Units System Units	0: WC:InchOfWater 1: PSI:lb/SqrInch 2: GPM:Gallons/Min 3: F:DegFahrenheit 4: CFM:Cubic ft/Min 5: CMH:Cubic m/Hr 6: LPH:Liters/Hr 7: LPS:Liters/sec 8: Bar:Bar 9: Pa: Pascals 10: C: DegCelsius 11: Ft: Feet <0032> 12: %: Percent	0 to 12	1	Pump Quick Setup	—
P1-03	0602H	Feedback Device Scaling Fb Dev Scaling	Scaling of feedback device in user units (P1-02 = 1, e.g. 150PSI). Digits 1 through 4 set the maximum feedback number. Digit 5 determines the number of decimal places. Digit 5 = 0: Number format is XXXX Digit 5 = 1: Number format is XXX.X Digit 5 = 2: Number format is XX.XX Digit 5 = 3: Number format is X.XXX Examples: 01000 = 1000 13000 = 300.0 25000 = 50.00 32000 = 2.000	1 to 36000 (system units P1-02)	00145	Pump Quick Setup	—

The iQpump drive offers four Auto Mode Start/Stop selections to start and stop the iQpump drive and to enable Auto mode operation. The selections determined by the setting of parameters b1-01 and b1-02 are as follows:

Setting	Description
0	Operator
1	Terminals
2	Serial Com
3	Option PCB

Note: It is recommended to first select the system units and feedback device scaling. System units can be selected with parameter P1-02 (system units) and feedback range can be set with parameter P1-03 (feedback device scaling).

Example:

P1-02 System Units = 1: PSI (lb/SqrInch)

P1-03 Feedback Device Scaling = 200 (200PSI)

4.4 Pump Basics

◆ Feedback Device Scaling

Table 4.10

Parameter No.	Modbus Address	Parameter Name Digital Operator Display	Description	Setting Range	Factory Setting	Menu Location	Page No.
P1-03	0602H	Feedback Device Scaling Fb Dev Scaling	Scaling of feedback device in user units (P1-02 = 1, e.g. 150PSI). Digits 1 through 4 set the maximum feedback number. Digit 5 determines the number of decimal places. Digit 5 = 0: Number format is XXXX Digit 5 = 1: Number format is XXX.X Digit 5 = 2: Number format is XX.XX Digit 5 = 3: Number format is X.XXX Examples: 01000 = 1000 13000 = 300.0 25000 = 50.00 32000 = 2.000	1 to 36000 (system units P1-02)	00145	Pump Quick Setup	—

The installed feedback device requires the proper scaling. For proper installation of the feedback device, refer to **Chapter 3**. The feedback scaling is determined by programming the feedback device scaling parameter P1-03.

To make setting up the feedback scaling easier, first select the actual system units desired for the iQpump drive to regulate. The system units can be selected by programming the desired units in parameter P1-02.

Table 4.11

Setting	Description	Setting	Description
0	Inch or Water	7	Liters/sec
1	PSI	8	Bar
2	GPM	9	Pascal
3	Degrees Fahrenheit	10	Degrees Celsius
4	CFM	11	Feet
5	CMH	12	Percent
6	Liters	—	—

The feedback range can be specified with one single parameter: P1-03 Feedback Device Scaling. The maximum feedback value for the iQpump is 3600 (PSI, GPM, etc.).

If the monitors seem more natural in terms of PSI, set P1-02 = 1.

If another engineered unit, such as WC (Inches of Water) or GPM (Gallons per Minute), is desired, set P1-02 to the appropriate value. The setting programmed in the Feedback Device Scaling (P1-03) will determine the display at 100% and the position of the decimal point.

X X X X X
 Digit 5 Digit 4 Digit 3 Digit 2 Digit 1

Digits 1 through 4 set the desired number to be displayed at 100% PSI.

Digit 5 determines the number of decimal places.

If Digit 5 = 0 number format is XXXX
 If Digit 5 = 1 number format is XXX.X
 If Digit 5 = 2 number format is XX.XX
 If Digit 5 = 3 number format is X.XXX

Example: If P1-02 = 1 (PSI) and P1-03 = 00145, then at 100% PSI, the digital operator would display 145 PSI for monitor U1-24 or U1-38.

Examples of Feedback Device Scaling

-DRIVE-	Rdy
Auto: Set-Point	
<u>U1-01 = 200 PSI</u>	
U1-02 =	0.00 Hz
U1-91 =	82.3 PSI

Example: Feedback range 200 PSI.
Program P1-03 to **00200**

-DRIVE-	Rdy
Auto: Set-Point	
<u>U1-01 = 20.00 PSI</u>	
U1-02 =	0.00 Hz
U1-91 =	82.3 PSI

Example: Feedback range 20.00 PSI.
Program P1-03 to **22000**

-DRIVE-	Rdy
Auto: Set-Point	
<u>U1-01 = 200.0 PSI</u>	
U1-02 =	0.00 Hz
U1-91 =	82.3 PSI

Example: Feedback range 200.0 PSI.
Program P1-03 to **12000**

-DRIVE-	Rdy
Auto: Set-Point	
<u>U1-01 = 2.000 PSI</u>	
U1-02 =	0.00 Hz
U1-91 =	82.3 PSI

Example: Feedback range 2.000 PSI.
Program P1-03 to **32000**

Figure 4.1 Feedback Device Scaling Examples

4.5 Use Feedback Level to Start iQpump Controller

◆ P1-04, P1-05

Table 4.12

Parameter No.	Modbus Address	Parameter Name Digital Operator Display	Description	Setting Range	Factory Setting	Menu Location	Page No.
P1-04 ◆	0603H	Start Level Start Level	Drive starts when the feedback level drops below the start level for a time specified in P1-05. This level also specifies the wake up level when the drive is in Sleep Mode. Note: When PID operates in the reverse mode, the feedback value has to rise above the start level for the time programmed in P1-05 for the system to start. A value of 0 disables this function.	0.0 to 6000.0 (system units P1-02)	0.0 (system units P1-02)	Pump Quick Setup	—
P1-05 ◆	0604H	Start Level Delay Time S-Lvl Delay Time	Drive starts when the feedback level drops below the start level for a time specified in P1-05.	0 to 3600	0 sec	Pump Quick Setup	—

◆ Denotes that parameter can be changed when the Drive is running.

The iQpump drive has a built-in function that allows the system to start regulating when the feedback signal drops below a programmed start level (P1-04) for a programmed start level delay time (P1-05).

In many constant pressure applications, it is necessary to start the pump at different feedback levels along with a timer to ensure that the pump does not cycle on and off, if the pressure is floating too close to the start level. Due to system losses and leaks in pipes, the pressure will slowly decrease and it is desirable for the iQpump drive system to sense this changing level and automatically restart the automatic regulation back to desired setpoint.

Example: Constant Pressure System

System Units set to PSI (P1-02 = PSI)

System Setpoint set for 80 PSI

Pressure Transducer: 150 PSI

Desired Operation:

Pump System should start regulating when pressure drops below 70 PSI.

Solution:

Program P1-04 to 70 PSI and P1-05 to 2 sec.

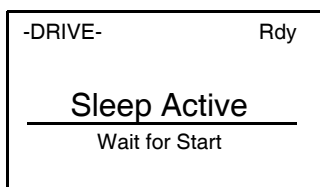

Display shows **Sleep Active** message when iQpump waits for feedback signal to fall below programmed level P1-04.

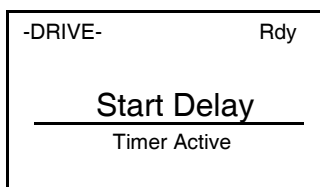

Display shows **Start Delay** message when feedback signal has dropped below programmed level P1-04 and the system is about to start after P1-05 timer expires.

Figure 4.2 Constant Pressure System

Note: In order for the system to start regulating, the Run command has to be present. (See **4.3 Pump System Start/Stop**).

4.5 Use Feedback Level to Start iQpump Controller

TIMING CHART: Start Level Operation

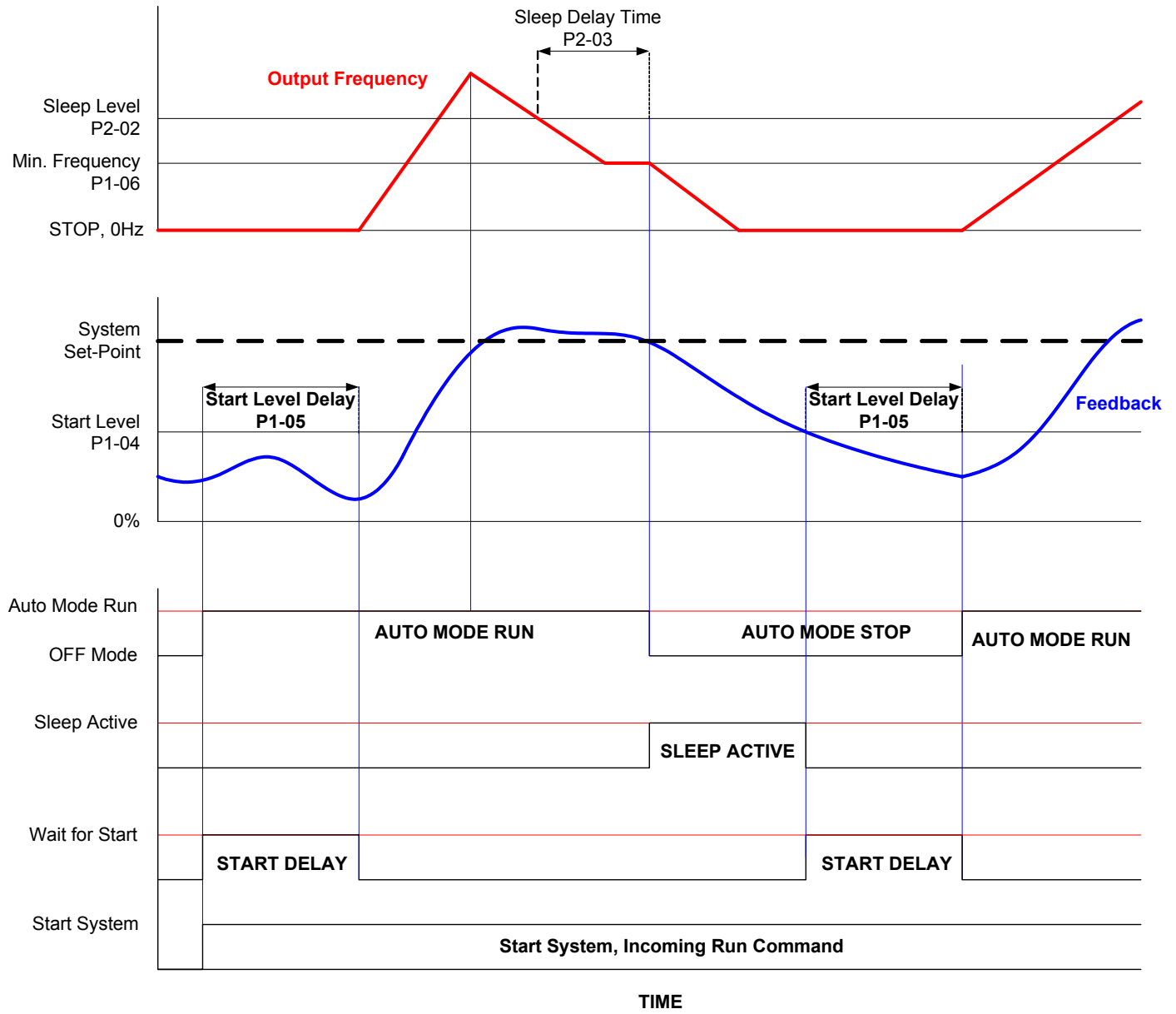

Figure 4.3 Start Level Operation

4.6 Low Feedback Level Alarm and Fault Setup

◆ P1-07, P1-08, P1-13

Table 4.13

Parameter No.	Modbus Address	Parameter Name Digital Operator Display	Description	Setting Range	Factory Setting	Menu Location	Page No.
P1-07 ◆	0606H	Low Feedback Level Low FB Level	The Drive will display a “Low Feedback (LFB)” alarm when the feedback level falls below the programmed level. The alarm will turn off when the feedback level rises above the programmed Low Feedback Level plus the Hysteresis Level (P1-13). A value of 0 disables this function. This function is only active during running while operating in the auto mode.	0.0 to 6000.0 (system units P1-02)	0.0 (system units P1-02)	Pump Quick Setup	—
P1-08 ◆	0607H	Low Feedback Level Fault Delay Time Low Lvl FLT Time	The Drive will display a “Low Feedback/Water (LFB/LW)” alarm when the feedback level falls below the programmed level for a time specified in P1-08. The Drive will coast to a stop when a fault occurs. A value of 0 disables this function. This function is only active during running while operating in the auto mode.	0 to 3600 sec	5 sec	Pump Quick Setup	—
P1-13 ◆	0108H	Hysteresis Level Hysteresis Level	Hysteresis Level used for low and high feedback alarm detection. See function P1-07 and P1-09.	0.0 to 100.0 (system units P1-02)	0.0 (system units P1-02)	Pump Quick Setup	—

◆ Denotes that parameter can be changed when the Drive is running.

The iQpump drive continuously monitors the systems feedback device and has the ability to show an alarm or even fault the iQpump drive when the feedback signals fall below a programmed low feedback level (P1-07) for a programmed low feedback level fault delay time (P1-08).

The hysteresis level (P1-13) determines the low feedback alarm turn-off level. In case of a low feedback alarm, the alarm message will turn-off when the feedback level rises above the programmed low feedback level (P1-07) plus the hysteresis level (P1-13).

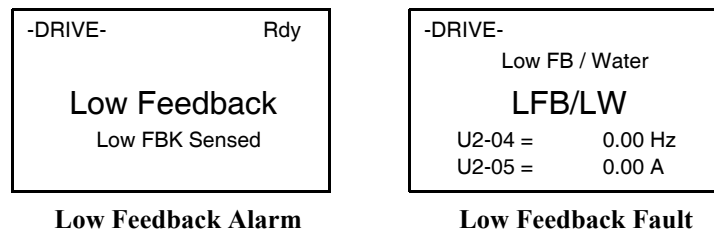

Figure 4.4 Low Feedback Alarm and Fault Displays

4.6 Low Feedback Level Alarm and Fault Setup

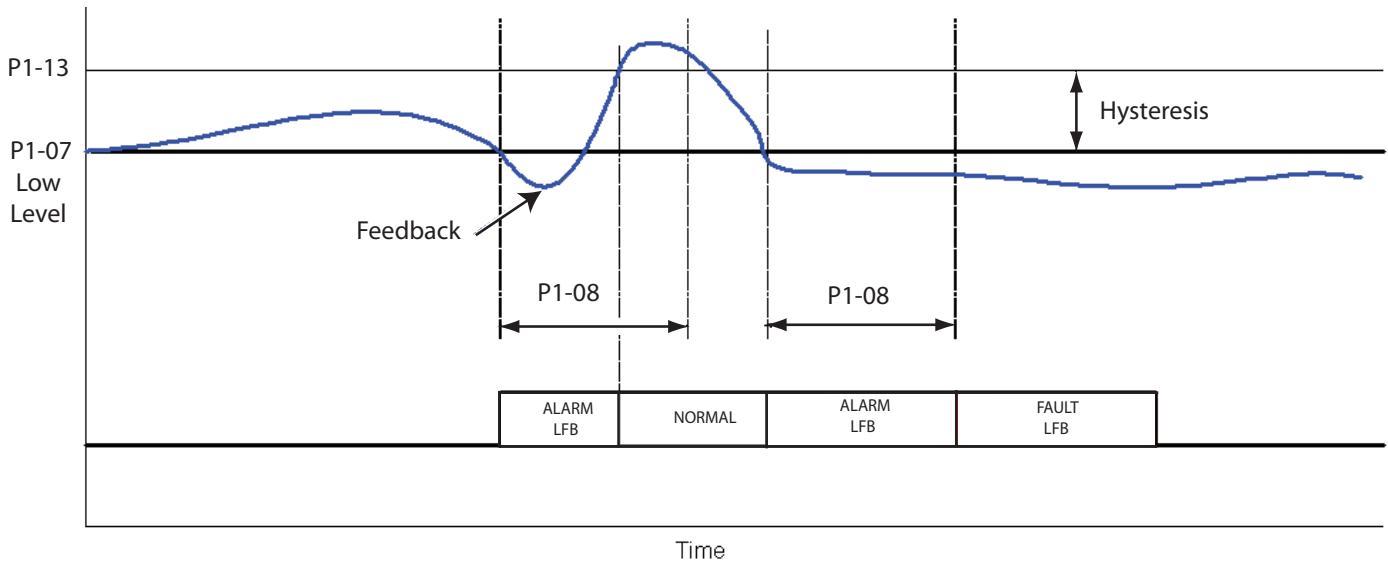

Figure 4.5 Low Feedback Timing Chart

Example: Constant Pressure System

System Units set to PSI (P1-02 = PSI)
System Setpoint set for 80 PSI
Pressure Transducer: 150 PSI

Desired Operation:

Pump System should show **low feedback alarm** when feedback level falls below 50 PSI and fault the system if the feedback level stays there for more than 30 sec.

Solution: Program P1-07 to 50 PSI and P1-08 to 30 sec.

Note: Low feedback detection is only active during running in Auto Mode.

4.7 High Feedback Level Alarm and Fault Setup

◆ P1-09, P1-10, P1-13

Table 4.14

Parameter No.	Modbus Address	Parameter Name Digital Operator Display	Description	Setting Range	Factory Setting	Menu Location	Page No.
P1-09 ◆	0608H	High Feedback Level High FB Level	The Drive will display a “High Feedback Level (HFB)” alarm when the feedback level rises above the programmed level. The alarm will turn off when the feedback level falls below the programmed High Feedback Level minus the Hysteresis Level (P1-13). This function is active during running in the hand mode, auto mode, pre-charge and thrust-bearing mode.	0.0 to 6000.0 (system units P1-02)	155.0 (system units P1-02)	Pump Quick Setup	—
P1-10 ◆	0609H	High Feedback Level Fault Delay Time Hgh Lvl FLT Time	The Drive will initiate a “High Feedback Fault (HFB)” when the feedback level rises above the programmed level for a time specified in P1-10. The Drive will coast to a stop when a fault occurs. This function is active during running in all operation modes.	0 to 3600	2 sec	Pump Quick Setup	—
P1-13 ◆	0108H	Hysteresis Level Hysteresis Level	Hysteresis Level used for low and high feedback alarm detection. See function P1-07 and P1-09.	0.0 to 100.0 (system units P1-02)	0.0 (system units P1-02)	Pump Quick Setup	—

◆ Denotes that parameter can be changed when the Drive is running.

The iQpump drive continuously monitors the systems feedback device and has the ability to show an alarm and/or fault the iQpump drive when the feedback signals rise above a programmed high feedback level (P1-09) for a programmed high feedback level fault delay time (P1-10).

The hysteresis level (P1-13) determines the high feedback alarm turn-off level. In case of a high feedback alarm, the alarm message will turn-off when the feedback level falls below the programmed high feedback level (P1-09) minus the hysteresis level (P1-13).

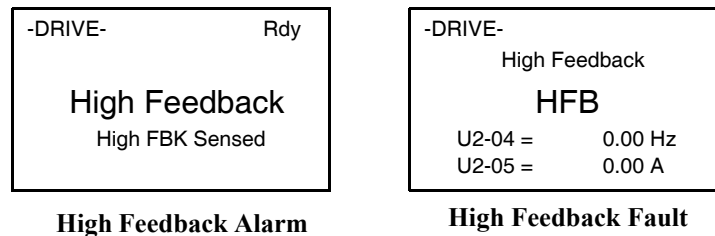

Figure 4.6 High Feedback Alarm and Fault Displays

4.7 High Feedback Level Alarm and Fault Setup

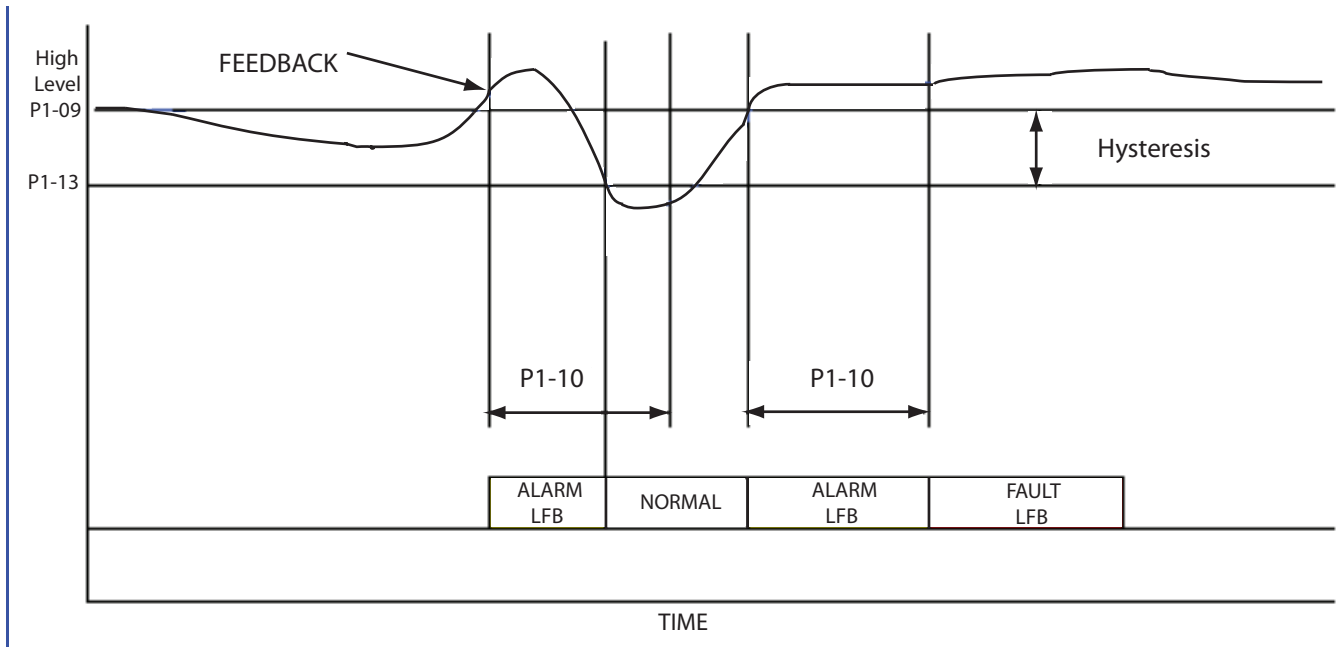

Figure 4.7

Example: Constant Pressure System

System Units set to PSI (P1-02 = PSI)

System Setpoint set for 80 PSI

Pressure Transducer: 150 PSI

Desired Operation:

Pump System should show High Feedback Alarm when feedback level rises above 90 PSI and fault the system if the feedback level stays there for more than 30 sec.

Solution: Program P1-09 to 90 PSI and P1-10 to 30 sec.

Note: High feedback detection is active during running in both Hand and Auto Mode.

4.8 Feedback Loss Detection

◆ b5-12, b5-13, b5-14

Table 4.15

Parameter No.	Modbus Address	Parameter Name Digital Operator Display	Description	Setting Range	Factory Setting	Menu Location	Page No.
b5-12	01B0H	PI Feedback Reference Missing Detection Selection Fb los Det Sel	0: Disabled 1: Alarm 2: Fault	0 to 2	0	Programming	101
b5-13	01B1H	PI Feedback Loss Detection Level Fb los Det Lvl	Sets the PI feedback loss detection level as a percentage of maximum frequency (E1-04).	0 to 100	0%	Programming	101
b5-14	01B2H	PI Feedback Loss Detection Time Fb los Det Time	Sets the PI feedback loss detection delay time in terms of seconds.	0.0 to 25.5	1.0 sec	Programming	101

The iQpump drive offers a feedback signal loss detection function in case the connected feedback device fails or a problem with the wiring occurs.

■ b5-12 PI Feedback Reference Missing Detection Selection

Setting	Description
0	Disabled (<i>factory default</i>)
1	Alarm
2	Fault

Factory default setting: 0: (Disabled)

To enable feedback loss detection, program parameter b5-12 to a value greater than 0 and b5-13 Feedback Loss Detection Level to the minimum feedback level for normal operation.

b5-13 Feedback Loss Detection Level Range: 0 to 100%

b5-14 Feedback Loss Detection Time Range: 0.0 to 25.5 sec. (1.0 Factory Default)

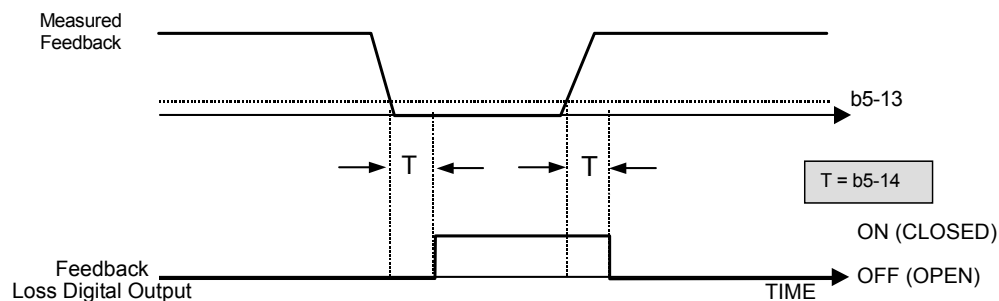

Figure 4.8 Loss of PI Feedback Feature

Example: Constant Pressure System

Pressure Transducer: 150 PSI (4 ~ 20mA)

Desired Operation:

Feedback Loss Fault when pressure falls below 15 PSI for more than 5.0 sec.

Solution:

Program b5-12 to 2 Feedback Loss Detection Fault

Program b5-13 to 10% (15 PSI divided by 150 PSI times 100% = 10%)

Program b5-14 to 5.0 sec.

4.9 Basic Pump Protection

The iQpump drive offers dedicated functions to protect the pump system from possible occurrences. The following section explains the basic pump protection that the iQpump drive offers. One or more of the basic protection functions can protect from occurrences such as:

- Dry Well
- Air in System
- Blocked Impeller
- No Water
- Low Feedback (e.g. Low System Pressure Detection)
- High Feedback (e.g. High System Pressure Detection)

◆ Pump System Shutdown When System Setpoint Cannot Be Maintained

The iQpump drive continuously monitors pump system regulation and is able to shutdown the pump system after a programmable time in case the system is not able to maintain the system setpoint. The Pump Protection function consists of 2 parameters:

Table 4.16

Parameter No.	Modbus Address	Parameter Name Digital Operator Display	Description	Setting Range	Factory Setting	Menu Location	Page No.
P1-11 ◆ <0032>	0106H	Maximum Setpoint Difference Max SetPoint Diff	When the Drive is running and the difference between the setpoint and the feedback exceeds the level in P1-11 for the time specified in P1-12, the Drive will trip on a “Not Maintaining Setpoint (NMS)”. The Drive will coast to a stop when a fault occurs. A value of 0 disables this function. This function is only active during running while operating in auto mode.	0.0 to 6000.0 (system units P1-02)	0.0 (system units P1-02)	Pump Quick Setup	—
P1-12 ◆ <0032>	0107H	Not Maintaining Setpoint and Loss of Prime Time Setpoint-LOP Tim	Delay time before a Not Maintaining SetPoint or Loss of Prime Time fault occurs. Pump protection criteria specified in P1-11 or P1-14 must be met for the Drive to fault. The Drive will coast to a stop when a fault occurs. A value of 0 disables both Loss of Prime and Not Maintaining SetPoint faults.	0 to 3600	60 sec	Pump Quick Setup	128

◆ Denotes that parameter can be changed when the Drive is running.

■ P1-11 Maximum Setpoint Difference: (Factory Default is 0.0 = Disabled)

The iQpump drive can be configured to display a Not Maintaining Setpoint (NMS) fault when the difference between the setpoint and the feedback exceeds the Maximum Setpoint Difference (P1-11). When the Maximum Setpoint Difference has been exceeded, the drive will trip on NMS fault and will coast to a stop when the fault occurs.

Setting P1-11 to a value of 0 will disable this function. This function is only active during operation in the Auto Mode.

The Maximum Setpoint Difference (P1-11) works in conjunction with the Not Maintaining Setpoint and Loss of Prime Time (P1-12). The units for this parameter are determined by the System Units (P1-02)

■ P1-12 Not Maintaining Setpoint and Loss of Prime Time: (Factory Default is 60 sec.)

The iQpump drive can be configured to display a Maximum Setpoint Difference (P1-11) fault when the difference between the setpoint and the feedback are exceeded for the time programmed in the Not Maintaining Setpoint and Loss of Prime Time (P1-12). The drive will coast to a stop after the level has been exceed for the specified time programmed in P1-12.

This function is only active during operation in the Auto Mode.

The Not Maintaining Setpoint and Loss of Prime time (P1-12) is also used for the Prime Loss Level (P1-14) function. refer to Prime Loss Level (P1-14) for further description.

The Not Maintaining Setpoint and Loss of Prime Time (P1-12) works in conjunction with Maximum Setpoint Difference (P1-11) and Prime Loss Level (P1-14).

Note: The time value programmed into P1-12 is shared by Maximum Setpoint Difference (P1-11) and Prime Loss Level (P1-14) functions. However, independent times are maintained. If one function time, such as P1-11, has elapsed, the other functions time (P1-14) is still maintained until this time has elapsed.

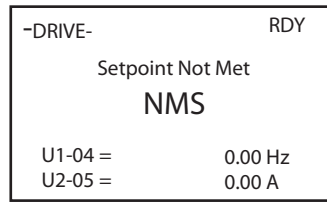

Figure 4.9 Not Maintaining Setpoint (NMS) Fault Display

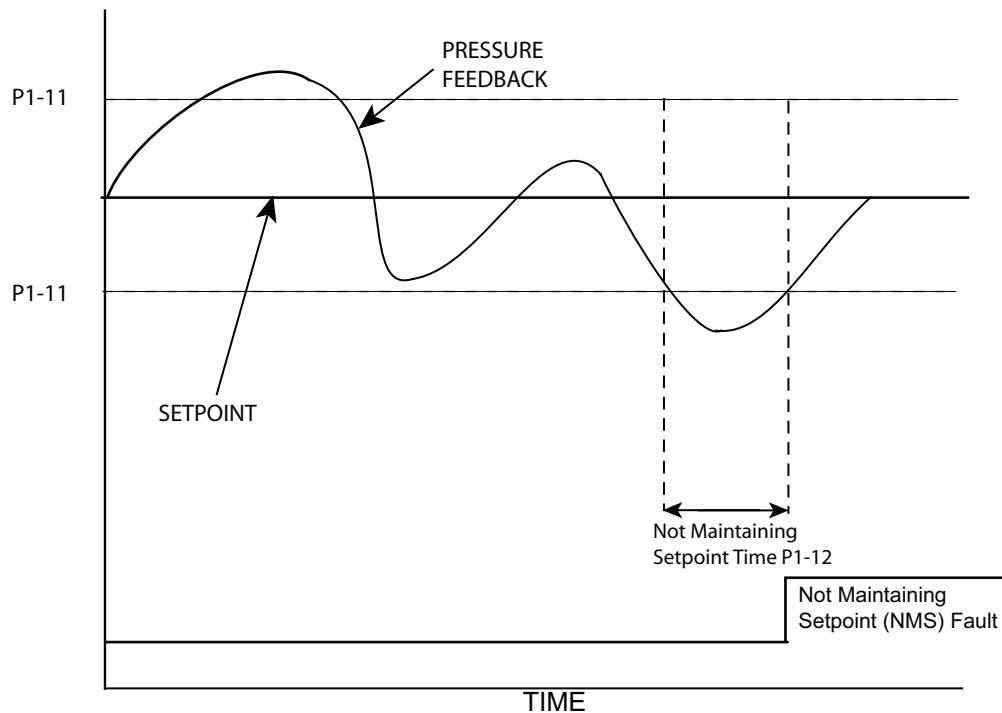

Figure 4.10

Example: Constant Pressure System

System Units set to PSI (P1-02 = PSI)

System Setpoint set for 80 PSI

Pressure Transducer: 150 PSI

Desired Operation:

Pump System should shutdown when the difference between the actual system pressure (transducer feedback level) and the system setpoint (80 PSI) is greater than 10 PSI continuously for more than 40 sec.

Solution:

Program P1-11 to 10 PSI

Program P1-12 to 40 sec.

The Pump Protection function is only active during running while operating in auto mode. On fault, the iQpump drive will coast to a stop.

4.9 Basic Pump Protection

THIS PAGE INTENTIONALLY LEFT BLANK.



Basic Programming

This Manual contains descriptions of all user accessible parameters contained in the iQpump drive. Parameters are listed in alpha-numerical order. Parameter number and name, along with a detailed description and its settings are described on the following pages.

5.1 iQpump Basic Programming Parameters	88
5.2 Pump Basic	127
5.3 Pump Protection	130
5.4 T1 Auto Tuning	134

5.1 iQpump Basic Programming Parameters

The initialization group contains parameters associated with initial set-up of the iQpump drive. Parameters involving the display language, access levels, initialization and password are located in this group.

◆ A1 Initialization

■ A1-01 Access Level Selection

Setting	Description
0	Operation Only
2	Advanced Level (<i>factory default</i>)

If the iQpump drive is programmed for Operation Only (A1-01 = “0: Operation Only”), then only the OPERATION and the PROGRAMMING menus are accessible. Within the PROGRAMMING menu only parameters A1-01 and A1-04 are adjustable.

If A1-01 is configured for Advanced Access (A1-01 = “2: Advanced Level”), then all menus and all parameters are shown. If the Access Level Selection is set to Advanced, all parameters should be adjustable unless:

1. The iQpump drive parameters are password protected (A1-04) which will prevent access to A1-00 through A1-03 and all A2 parameters.
2. A digital input has been configured as a Program Lockout (H1-0X = 1B) is active.
3. During serial communication writing, if a parameter change is also attempted via the digital operator, a “BUSY - WRITE PROTECTED” message will display. Parameter change will not be possible from the digital operator until an Enter command is received via the serial communication to finish the serial writing process.

■ A1-03 Initialize Parameters

Setting	Description
0	No Initialize (<i>factory default</i>)
1110	User Initialize
2220	2-Wire Initialize
3330	3-Wire Initialize

The iQpump drive can be set back to one of three default states via the A1-03 parameter.

1. User Initialization – 1110: The modified iQpump drive parameters are returned to the values selected as user settings. User settings are stored when parameter o2-03= “1: Set Defaults.”
2. 2-Wire Initialization – 2220: The iQpump drive parameters are returned to factory default values with digital inputs S1 and S2 configured as Forward Run and Reverse Run, respectively.
3. 3-Wire Initialization – 3330: The iQpump drive parameters are returned to factory default values with digital inputs S1, S2, and S5 configured as Run, Stop, and Forward/Reverse respectively.

After an initialization is performed, parameter A1-03 will automatically be set back to 0.

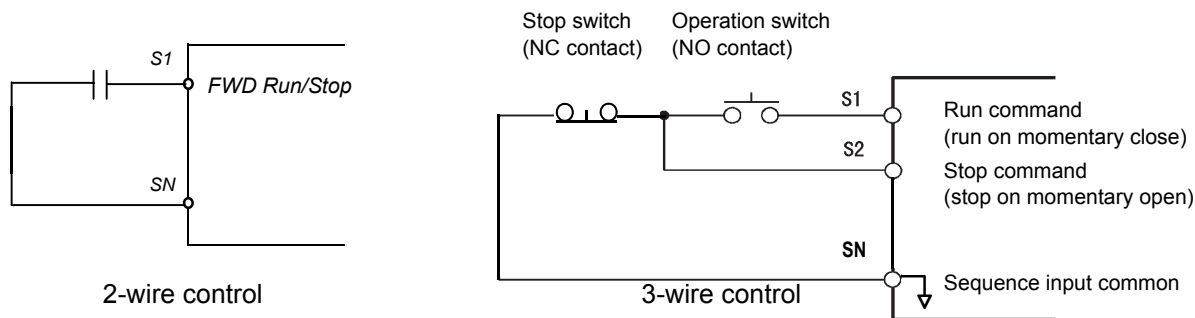

Figure 5.1 2 & 3-Wire Control Wiring Examples

Important: Some parameters are unaffected by either the 2-wire or 3-wire initialization. The following parameters will not be reset when parameter A1-03 = 2220 or 3330:

A1-00	Language Selection
E1-03	V/f Pattern Selection
o2-04	kVA Selection

◆ b1 Sequence

The Sequence Group contains parameters associated with starting and stopping the iQpump drive. Parameters involving the Run Command, Speed Reference and Setpoint location, Stopping Method and Hand/Auto changeover are located in this group.

■ b1-01 Frequency Reference Selection

Setting	Description
0	Operator - Digital Preset Speed d1-01 (<i>factory default</i>)
1	Terminals - Analog Input Terminal A1 (or Terminal A2, see Parameter H3-13)
2	Serial Com - RS-485 Terminals R+, R-, S+ and S-
3	Option PCB - Option Board connected at 2CN

In order to run the iQpump drive and motor, the iQpump drive must receive a Run command and a Auto Setpoint command. Parameter b1-01 specifies from where the Auto setpoint is received when in the “Auto” mode. Switching into the “Auto” mode can be done by pressing the AUTO button on the digital operator while the iQpump drive is stopped.

Important: If a Run command is input to the iQpump drive but no corresponding Auto setpoint is input, the Run indicator on the digital operator will turn on and the STOP indicator on the digital operator will blink.

If you want the iQpump drive to follow the “Hand Reference” set by the digital operator: Use the “Hand” mode by pressing the hand key and set P5-01 = “1: Hand Reference (P5-02).” The hand reference can then be entered into the U1-01 monitor parameter in the “-DRIVE-” Menu.

The iQpump drive offers the ability to provide four types of “Auto Setpoint” reference sources. These Auto Setpoint reference sources are determined by the setting of b1-01 and the drive set to “Auto” mode by pressing the Auto key on the digital operation.

Note: Prior to programming, it is recommended to first select the system units (P1-02) and the feedback device, Scaling (P1-03). P1-03 will automatically scale the iQpump setpoint. Please refer to [Section 4.1 Start Up](#) for further set up details.

Example:

P1-02 = 1: PSI

P1-03 = 200, feedback range = 200 PSI.

If you want the iQpump drive to follow an “Auto Set-Point” set by the digital operator: Set b1-01 = “0: Operator” (factory default), The Auto setpoint can then be entered into the U1-01 monitor parameter in the “-DRIVE-” menu.

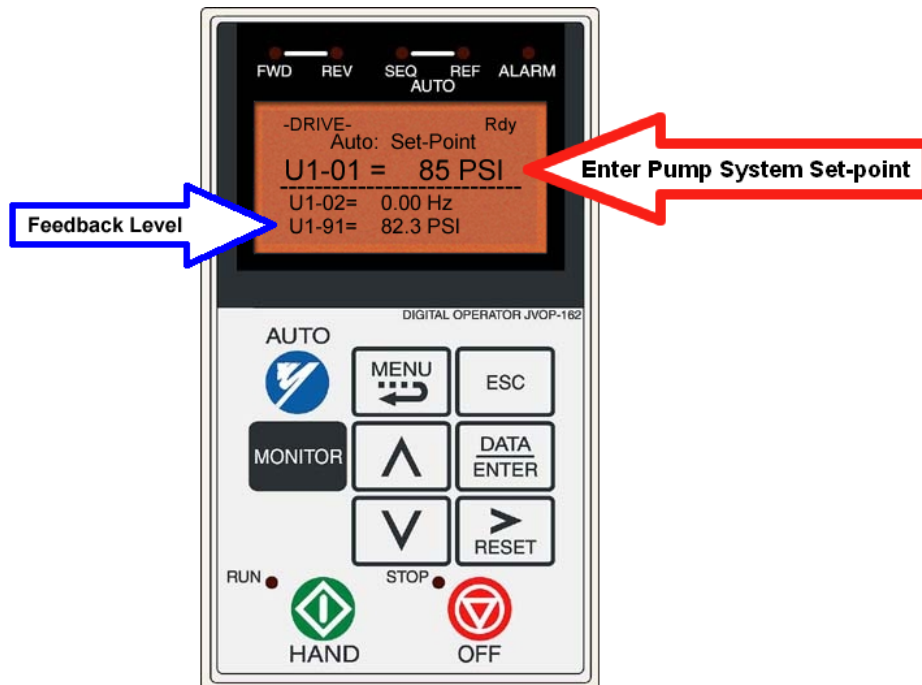

Figure 5.2 Digital Operator Auto Setpoint

If you want the iQpump drive to follow an “Auto Setpoint” set by the analog input: Set b1-01 = “1: Terminals,” and connect a potentiometer or external signal to the iQpump drive. Refer to [Figure 5.3](#) for connection diagram for the setpoint potentiometer.

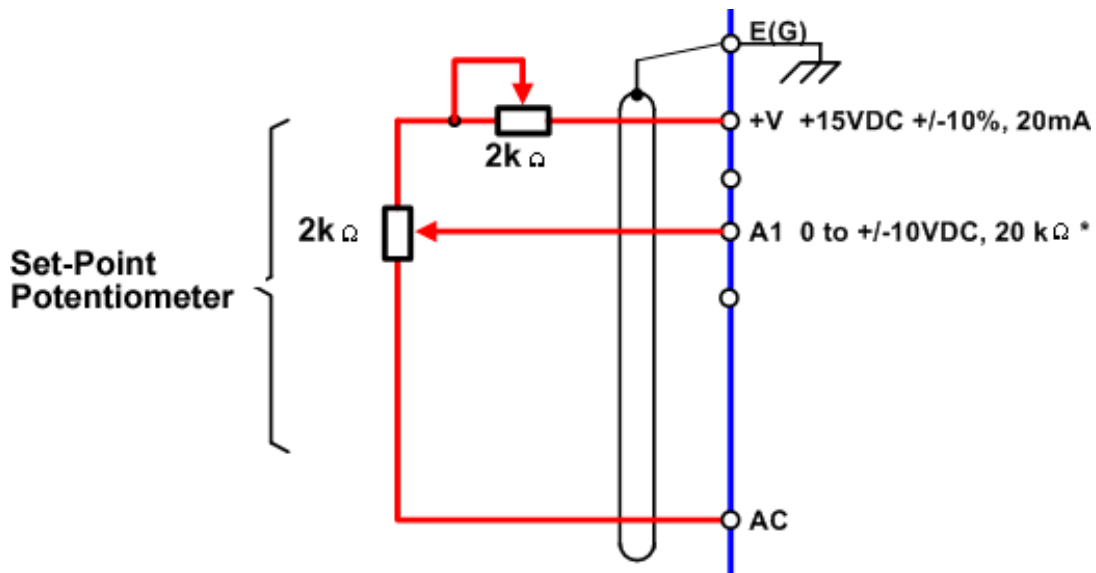

Figure 5.3 Setpoint Potentiometer Connection Diagram

Refer to [Figure 5.4](#) for the connection diagram for an external analog signal setpoint reference.

Note: When b1-01 = 1 (terminals) and P5-01 = 0 (hand mode reference source), the setpoint and the hand reference are determined by the external analog signal.

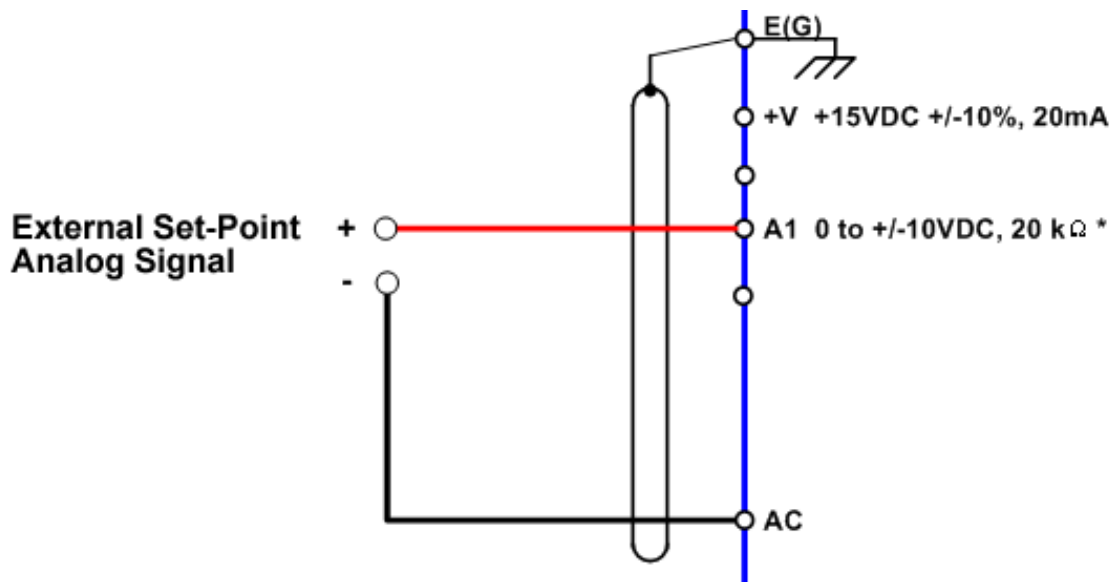

Figure 5.4 External Analog Signal Setpoint Reference

If you want the iQpump drive to receive the “Auto Setpoint” from serial communication: Set b1-01 = “2: Serial Com,” and connect the RS-485/422 serial communications cable to terminals R+, R-, S+, and S- on the control I/O terminal block.

Refer to [Figure 5.5](#) for the connection diagram using a PC to provide the auto setpoint reference to the iQpump drive. Further information regarding Modbus address and communication protocols are referenced in the [Section Appendix: A](#) and [Section Appendix: D](#).

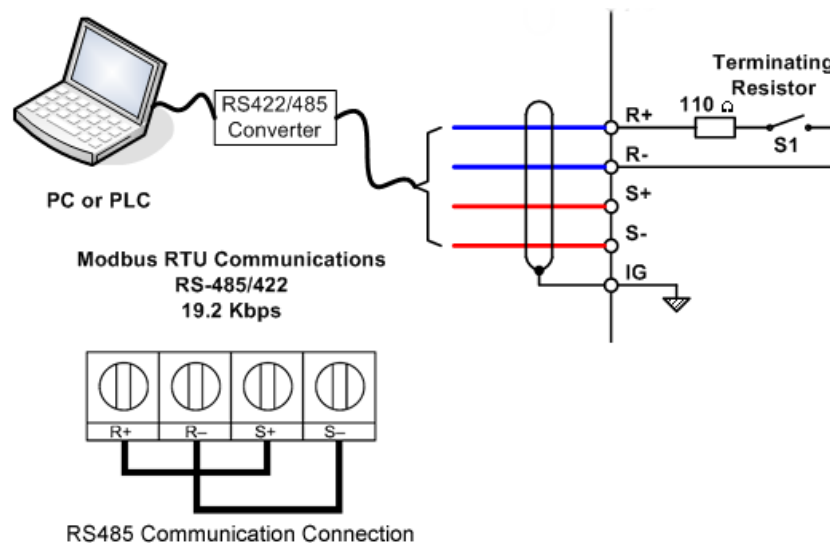

Figure 5.5 Connection Diagram of PC or PLC

If you want the iQpump drive to receive the “Auto Setpoint” for a network communication option card: Set b1-01 = “3: Option PCB”, and plug a network option board (p/n SI-J) into the 2CN port on the iQpump drive Control PCB. Consult the manual supplied with the option board for instructions on integrating the iQpump drive into the network system.

The iQpump drive can support the following network communication options. Refer to the appropriate Installation Guide (IG) and Technical Manual (TM) for further details. These network communications documents can be located at <http://iQpump.yaskawa.com>.

- | | |
|-----------------------------------|-------------------|
| • Profibus DP Option Card CM061 | Manual: IG.AFD.12 |
| • DeviceNet Option Card CM05X | Manual: IG.AFD.14 |
| • Modbus Plus Option Card CM071 | Manual: IG.AFD.17 |
| • Modbus TCP/IP Option Card CM090 | Manual: IG.AFD.25 |
| • EtherNet/IP Option Card CM092 | Manual: IG.AFD.26 |

5.1 iQpump Basic Programming Parameters

Important: If b1-01= “3: Option PCB” but a network card is not installed in 2CN, an OPE05 Operator Programming Error will be displayed on the digital operator and the iQpump drive will not run.

■ b1-02 Run Source

Setting	Description
0	Operator (<i>factory default</i>)
1	Terminals
2	Serial Com
3	Option PCB

■ Start/Stop from Keypad (Parameter b1-02 = 0)

The iQpump drive comes factory programmed for Start and Stop from the Keypad.

The iQpump drive can be programmed to receiver a Run command from four different inputs: digital operator, terminals, serial communications, or an option PCB.

If the Run command input is determined by the digital operator: Set b1-02 = “0: Operator,” and the hand key will be used to provide the Run command to the iQpump drive.

If the Run command input is determined by the external terminals: Set b1-02 = “1: Terminals” and initiate an external Run command by a contact closure between terminals S1 and SN. Refer to [Figure 5.6](#) for the connection diagram of the external Run command.

Note: To use the external terminals requires the iQpump drive to be set to “Auto” mode by pressing the Auto key.

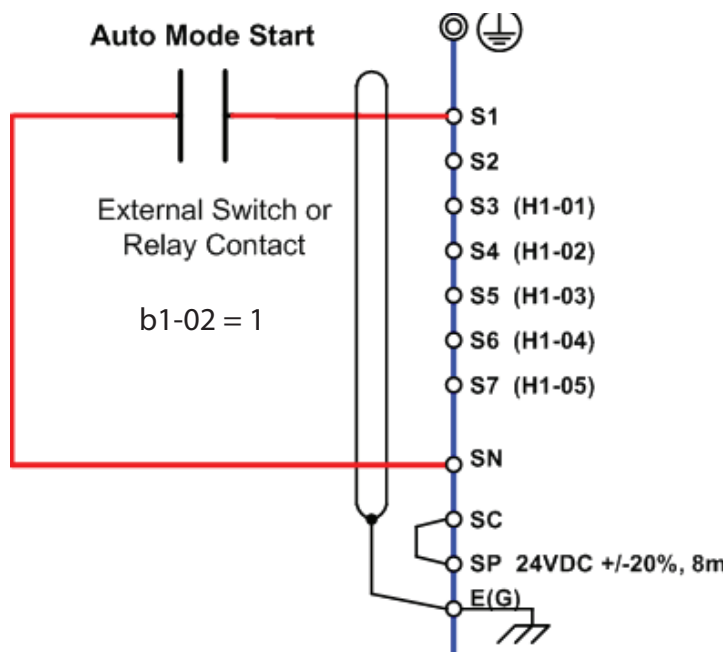

Figure 5.6 Connection Diagram of External Start/Stop Switch

If the Run command is determined by Serial Communications: b1-02 = “2: Serial Communications,” and initiate the Run command through the serial communications. Refer to [Figure 5.5](#) (in the previous b1 sequence section) for the connection diagram for serial communications through the RS232/485 terminals. The following is a simple setup procedure for programming the iQpump drive and PC Serial communications to initiate Run and Stop commands through serial communications. [Section Appendix: E](#) has further details on the Modbus communications.

1. Program b1-02 = “2: Serial communications.”
2. Program the following H5 parameters:
 - H5-01 Serial Communication Address: 31
 - H5-02 Serial Baud Rate: 9600 Baud (setting 3).
 - H5-03 Serial Communication Parity Selection: None (setting 0).
3. Initiate a Start/Stop command

iQpump command register number: 0001

Stop Command: Transmit value of **0000** (16 bit) to iQpump command address.

Start Command: Transmit value of **0001** (16 bit) to iQpump command address.

Reset Command: Transmit value of **0008** (16 bit) to iQpump command address.

If the Run command input is determined by a network communications option PCB: b1-02 = “3: Option PCB,” and initiate the Run command through the available network communications option PCB listed below. The Installation Guides (IG) and Technical Manuals (TM) are available at <http://iQpump.yaskawa.com>.

The iQpump Controller allows for monitoring, diagnostics and control using any of the following communication option cards:

- Profibus DP Option Card CM061 Manual: IG.AFD.12
- DeviceNet Option Card CM05X Manual: IG.AFD.14
- Modbus Plus Option Card CM071 Manual: IG.AFD.17
- Modbus TCP/IP Option Card CM090 Manual: IG.AFD.25
- EtherNet/IP Option Card CM092 Manual: IG.AFD.26

Note: Refer to the [communication card instruction manual](#) or consult factory for installation and operation instructions.

■ Start/Stop from Comm. Option Card (Parameter b1-01 = 3):

The iQpump Controller allows for the Setpoint reference to be set via any of the following communication option cards:

- | | |
|-----------------------------------|-------------------|
| • Profibus DP Option Card CM061 | Manual: IG.AFD.12 |
| • DeviceNet Option Card CM05X | Manual: IG.AFD.14 |
| • Modbus Plus Option Card CM071 | Manual: IG.AFD.17 |
| • Modbus TCP/IP Option Card CM090 | Manual: IG.AFD.25 |
| • EtherNet/IP Option Card CM092 | Manual: IG.AFD.26 |

■ Feedback Device

The iQpump Controller requires a feedback device (e.g. Pressure transducer, flow meter, etc.) to perform automatic system regulation. Any analog 0~10V or 4-20mA feedback device can be used in combination with the iQpump controller.

Connecting Your Feedback Device to the iQpump Controller

Note: The factory default setting for the iQpump controller is 4~20mA feedback device connected to analog input A2.

To successfully operate the iQpump drive remotely, an external run command must be received by the iQpump drive. Parameter b1-02 specifies from where the run command will be accepted.

Although the Run Source and the Reference Source (b1-01) are normally taken from the same source (e.g. digital operator, terminals or serial communication), this is not always the case.

To issue a run command from the digital operator: Set b1-02 = “0: Operator,” and use the HAND and OFF buttons to start and stop the iQpump drive.

To issue the run command from the terminals: Set b1-02 = “1: Terminals,” and select between 2-wire and 3-wire control operation by doing the following:

2-Wire Control The factory default setting is for 2-wire operation. In the 2-wire configuration a closure between S1 and SN will be interpreted as a Forward Run command by the iQpump drive.

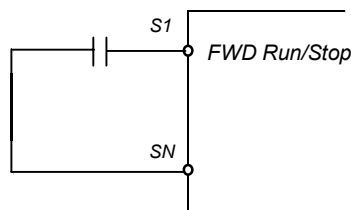

Figure 5.7 2-Wire Control



3-Wire Control When any of the multi-function digital input parameters, H1-01 through H1-05, is set to 0, terminals S1 and S2 become Run and Stop, respectively. The multi-function digital input that was set to 0 will function as a Forward/Reverse input for the iQpump

5.1 iQpump Basic Programming Parameters

drive. When the Forward/Reverse input is open the iQpump drive will run in the Forward direction and when the input is closed, the iQpump drive will run in the Reverse direction.

In 3-wire operation a momentary closure (> 50 mS) of S1 will cause the iQpump drive to run provided that S2 is held closed. The iQpump drive will stop anytime the S2-SN connection is broken. If the 3-wire configuration is implemented via a 3-wire Initialization (A1-03 = “3330: 3-Wire Initial”), then terminal S5 becomes the Forward/Reverse input.

Note: Reverse operation is disabled in the iQpump drive; however, in 3-wire control, one of the multi-function digital inputs needs to be programmed to 0. Otherwise, the 3-wire control will not work.

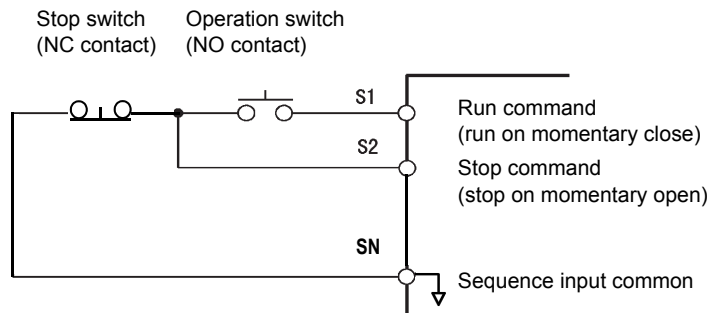

Figure 5.8 3-Wire Control

To issue a Run command via serial communication: Set b1-02 = “2: Serial Com” and connect the RS-485/422 serial communication cable to R+, R-, S+, and S- on the removable terminal block.

To issue the Run command via the network option card: Set b1-02= “3: Option PCB”, and plug a network option board (p/n SI/J) into the 2CN port on the Control PCB. Consult the manual supplied with the option board for instructions on integrating the iQpump drive into your network System.

Important: If b1-01= “3: Option PCB” but a network card is not installed in 2CN, an “OPE05” operator programming error will be displayed on the digital operator and the iQpump drive will not run.

■ b1-03 Stopping Method

There are four methods of stopping the iQpump drive when the Run command is removed.

Setting	Description
0	Ramp to Stop (<i>factory default</i>)
1	Coast to Stop
2	DC Injection to Stop
3	Coast w/Timer

0: Ramp to stop: When the Run command is removed, the iQpump drive will decelerate the motor to 0 rpm. The rate of deceleration is determined by the active deceleration time. The factory default Decel Time is in parameter C1-02.

When the output frequency has dropped below the DC Injection Start Frequency in b2-01 (Default = 0.5 Hz) DC current will be injected in the motor at a level determined by b2-02 (50% Default). The DC Injection condition will occur for the time specified by b2-04 (0.0 Default), to establish the end point of the ramp. DC injection can be used to insure the motor is at zero rpm prior to the iQpump drive shutting off.

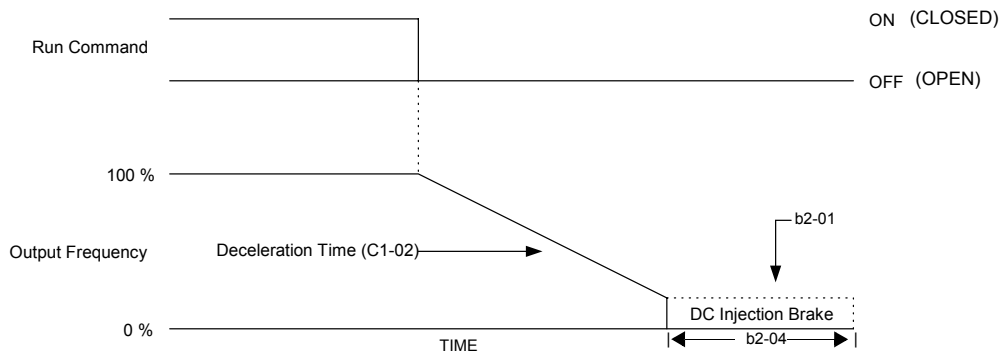

Figure 5.9 Deceleration to Stop

The actual deceleration time can be determined by the following formula.

$$\text{Time to Stop} = \frac{\text{Output Freq. at time of stop command}}{\text{Maximum Frequency (E1-04)}} \times \text{Setting of active Decel Time (C1-02 or C1-04)}$$

If S-Curve characteristics are specified by the iQpump drive programming, they will add to the total time to stop.

1: Coast to stop: When the Run command is removed, the iQpump drive will turn off its output and the motor will coast (uncontrolled deceleration). The friction of the driven equipment will eventually overcome any residual inertia of the system and the rotation will stop.

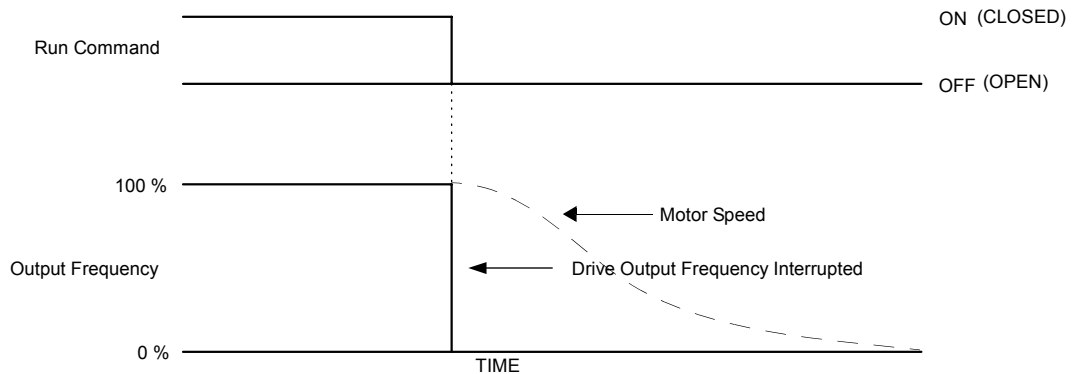

Figure 5.10 Coast to Stop

Important: After a stop is initiated, a subsequent Run commands input before the Minimum Baseblock Time (L2-03) has expired, will be ignored.

2: DCInj to Stop: When the Run command is removed, the iQpump drive will Baseblock (turn off its output) for the Minimum Baseblock Time (L2-03). Once the Minimum Baseblock Time has expired, the iQpump drive will inject DC current into the motor windings to lock the motor shaft. The stopping time will be reduced as compared to Coast to Stop. The level of DC Injection current is set by parameter b2-02 (50% Default). The DC Injection brake time is determined by the set value in b2-04 and the output frequency at the time the Run command is removed.

$$\text{DC Injection Brake Time} = \frac{(b2 - 04) \times 10 \times \text{Output Frequency}}{\text{Maximum Frequency (E1 - 04)}}$$

5.1 iQpump Basic Programming Parameters

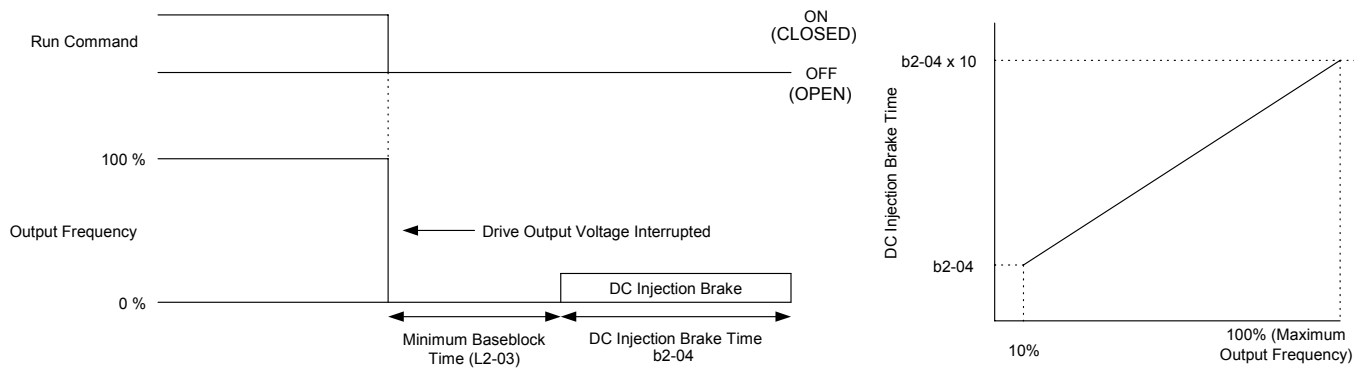

Figure 5.11 DC Injection Braking to Stop

Important: If an overcurrent (OC) fault occurs during DCInj to Stop, lengthen the Minimum Baseblock Time (L2-03) until the fault no longer occurs.

3: Coast w/Timer: When the Run command is removed, the iQpump drive will turn off its output and the motor will coast to a stop. If a Run command is input before time T (operation wait time) expires, the iQpump drive will not run and the Run command will need to be cycled before operation can occur. The time T (operation wait time) is determined by the output frequency when the Run command is removed and the active deceleration time (C1-02).

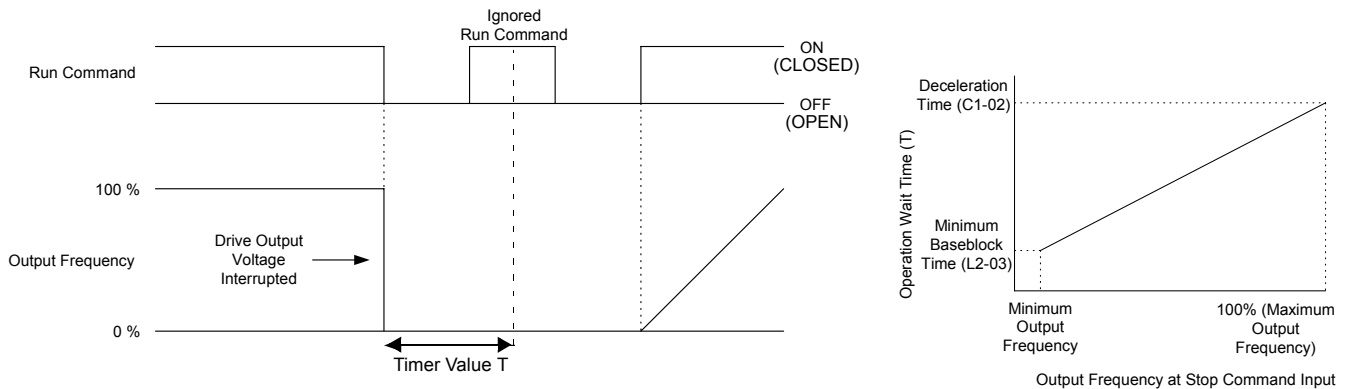

Figure 5.12 Coast to Stop with Timer

◆ b2 DC Braking

The DC Braking Group contains parameters associated with the DC injection braking feature. Parameters involving the starting frequency, current level, braking time, and motor pre heat current level are located here.

■ b2-01 DC Injection Braking Start Frequency

Setting Range: 0.0 to 10.0 Hz

Factory Default: 0.5 Hz

Parameter b2-01 sets the output frequency where the iQpump drive begins DC Injection during Ramp to stop in order to lock the rotor of the motor and established the end point of the ramp. If $b2-01 < E1-09$ (Minimum Frequency), then DC Injection begins at E1-09.

Parameter b2-01 also determines the output frequency that the iQpump drive must be at or below before a Zero Speed condition is considered true. This affects any digital output configured as a Zero Speed signal (H2-0x = "1: Zero Speed").

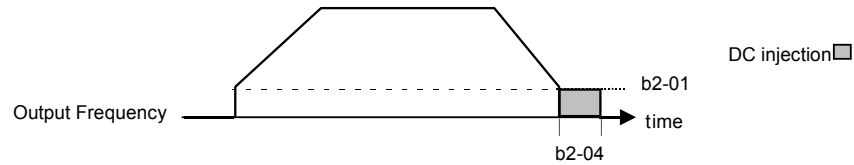

Figure 5.13 DC Injection Braking During Stopping

■ b2-02 DC Injection Braking Current

Setting Range: 0 to 100%
 Factory Default: 50%

The level of DC Injection Braking Current affects the strength of the magnetic field attempting to lock the motor shaft. Increasing the level of current will increase the amount of heat generated by the motor windings and should only be increased to the level necessary to hold the motor shaft. DC Injection current is set in percentage of iQpump drive rated output current. The iQpump drive rated output current is stated on the iQpump drive nameplate.

■ b2-03 DC Injection Braking Time at Start b2-04 DC Injection Braking Time at Stop

Setting Range: 0.00 to 10.00 sec
 Factory Default: b2-03 = 0.00 sec
 b2-04 = 0.00 sec

The iQpump drive can be programmed to automatically DC Inject for a predetermined amount of time prior to accelerating to speed (b2-03) and/or at the end of a Ramp to stop (b2-04). Parameter b2-03 can be used to stop a rotating motor prior to attempting acceleration (i.e. a wind milling fan). If DC Injection braking at start or Speed Search is not enabled, attempting to iQpump drive a spinning motor may cause nuisance tripping.

Parameter b2-04 can be used to resist any residual motion of the load after the deceleration has finished.

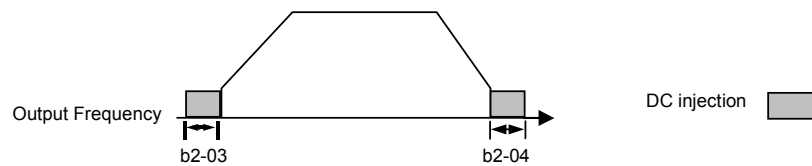

Figure 5.14 DC Injection Braking During Starting and Stopping

Parameter b2-04 also serves the function of affecting the length of time DC Injection to stop (b1-03 = “2: DC Injection to Stop”) will occur.

■ b2-09 Motor Pre-Heat Current

Setting Range: 0 to 100%
 Factory Default: 0%

A DC current can be circulated within the motor windings while the motor is stopped. The current will produce heat within the motor and prevent condensation. Parameter b2-09 determines the percentage of iQpump drive rated output current that will be used for the motor pre-heat function. This function can be useful in applications where the motor sits for extended periods of time in humid conditions. Motor pre-heating can only be initiated by closing a digital input programmed as a Motor Pre-heat Input (H1-0x = 60). Check with the motor manufacturer to determine the maximum acceptable current level the motor can withstand when stopped. Be sure not to exceed the motor manufacturers recommended level.

◆ b5 PI Function

The capability to accept an analog signal as feedback for a PI (Proportional + Integral) control function is built into the iQpump drive.

Speed Command / PI Setpoint

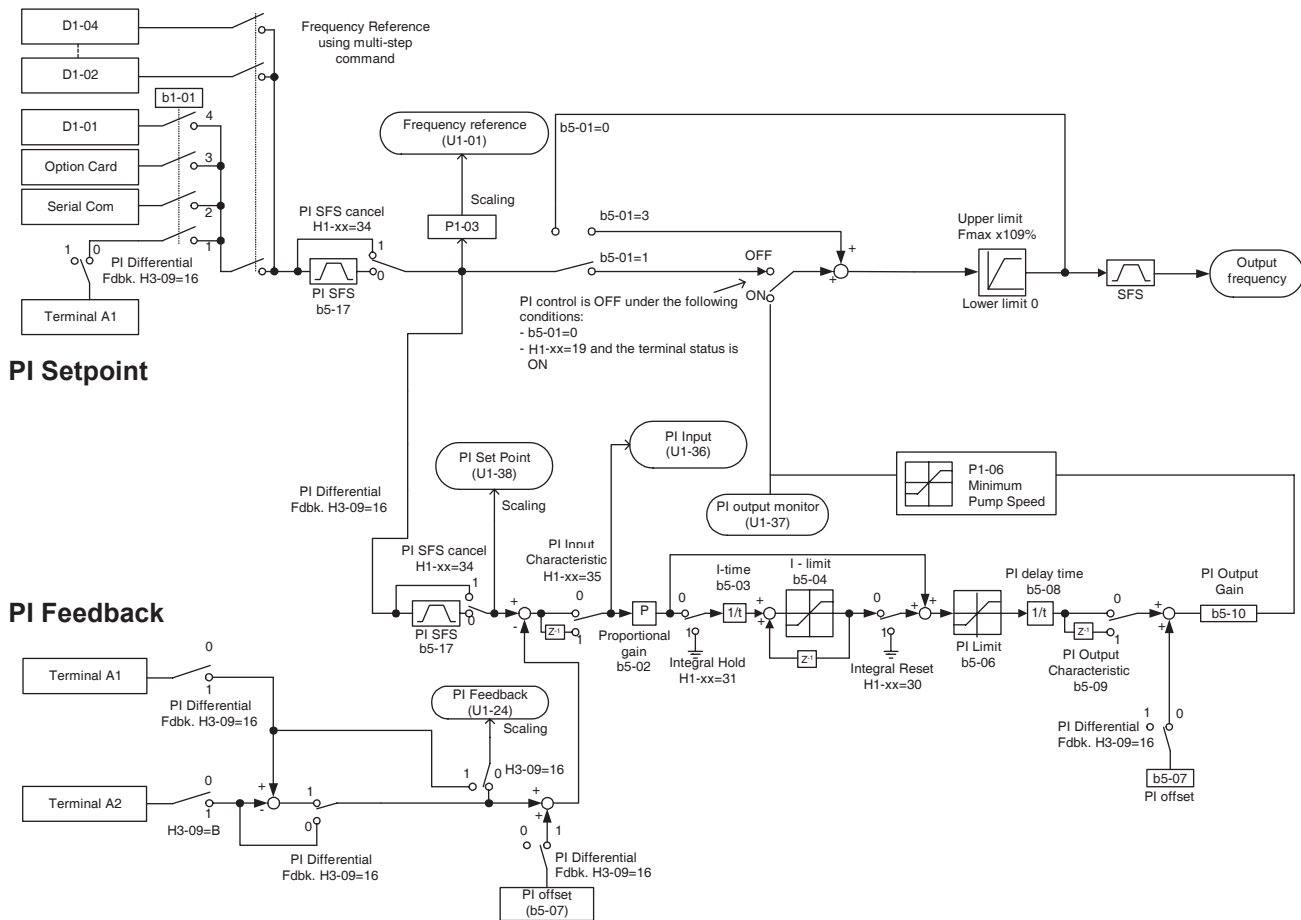

Figure 5.15 PI Block Diagram

The analog feedback to the iQpump drive for the PI control is via the A2 terminal. The iQpump drive must be programmed (H3-09 = “B: PI Feedback”) to use terminal A2 as feedback for the PI functionality of the iQpump drive.

The PI setpoint can be configured to come from one of many different inputs or parameters. [Table 5.1 on page 99](#) describes the options for originating the PI setpoint.

Table 5.1 PI Setpoint Options

The PI Setpoint will be read from:	If these conditions are true		
	Status of b5-18 =	Status of Modbus Register 0Fh bit 1	Status of b1-01 =
Parameter b5-19	1	N/A	N/A
Modbus Register 06H	0	ON	N/A
d1-01	0	OFF	0
Terminal A1	0	OFF	1
Serial Comm.	0	OFF	2
Option PCB	0	OFF	3

In some situations there are two feedback inputs. The iQpump drive can be programmed to maintain a set differential between two analog signals. If input A2 is configured as a “PI Differential Mode” (H3-09 = “16: PI Differential”), then the iQpump drive will maintain a set difference between the measurements read on inputs A1 and A2. This differential setpoint is programmed by parameter (b5-07).

■ b5-01 PI Mode Setting

Setting	Description
0	Disabled (<i>factory default</i>)
1	Enabled
3	Fref+PI

The iQpump drive can be used as a stand-alone PI controller. If PI functionality is selected by parameter b5-01, the iQpump drive will adjust its output to cause the feedback from a transmitter to match the PI setpoint (b5-19). The setting of b5-01 will determine whether PI functionality is disabled (b5-01 = “0: Disabled”), enabled (b5-01 = “1: Enabled”), or enable with the output of the PI function used to trim a Speed Command (b5-01 = “3: Fref+PI”).

■ b5-02 Proportional Gain Setting

Setting Range: 0.00 to 25.00
Factory Default: 2.00

The proportional gain will apply a straight multiplier to the calculated difference (error) between the PI Setpoint and the measured transmitter feedback at terminal A2. A large value will tend to reduce the error but may cause instability (oscillations) if too high. A small value may allow to much offset between the setpoint and feedback (See [Figure 5.16](#) on following page).

■ b5-03 Integral Time Setting

Setting Range: 0.0 to 360.0 sec
Factory Default: 5.0 sec

The Integral factor of PI functionality is a time-based gain that can be used to eliminate the error (difference between the setpoint and feedback at steady state). The smaller the Integral Time set into b5-03, the more aggressive the Integral factor will be. To turn off the Integral Time, set b5-03 = 0.00.

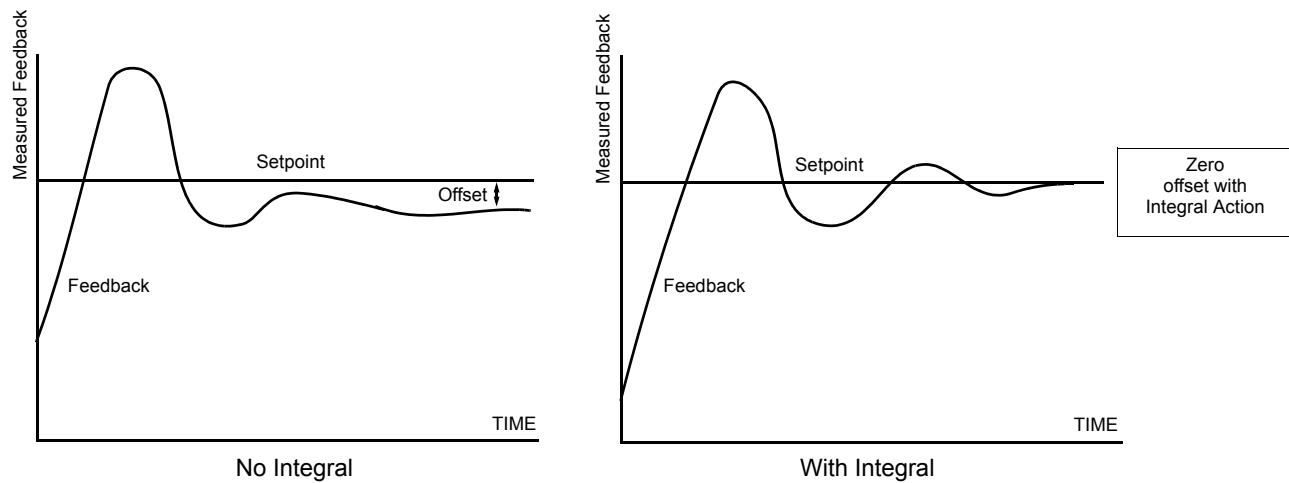

Figure 5.16 PI Feedback Response Characteristics

■ b5-04 Integral Limit Setting

Setting Range: 0.0 to 100.0%
Factory Default: 100.0%

On some applications, especially those with rapidly varying loads, the output of the PI function may have large oscillations. To suppress these oscillations, a limit can be applied to the integral factor by programming b5-04.

■ b5-06 PI Output Limit

Setting Range: 0.0 to 100.0%
Factory Default: 100.0%

Places a cap on the output of the PI function. Limiting the PI function may help to prevent large overshoots in the iQpump drive's response to error (the difference between the setpoint and the feedback).

■ b5-07 PI Offset Adjustment

Setting Range: -100.0% to +100.0%
Factory Default: 0.0%

The PI Offset Adjustment parameter has two different uses. Parameter b5-07 serves different functions depending on whether it is used on a standard PI loop or a Differential PI loop.

Parameter b5-07 causes an offset to be applied to the output of the PI function in a non-Differential PI loop. Every time the PI output is updated, the offset (b5-07) is summed with the PI output. This can be used to artificially kick-start a slow starting PI loop.

If the iQpump drive is configured for Differential PI Regulation (H3-09 = "16: PI differential"), then this parameter is the target setpoint for the differential to be maintained between the signal measured on analog input A1 and the signal measured on analog input A2.

■ b5-08 PI Primary Delay Time Constant

Setting Range: 0.00 to 10.00 sec
Factory Default: 0.00 sec

Acts as a time based filter that lowers the responsiveness of the PI function, but also makes the function more stable when the setpoint varies rapidly or when the feedback is noisy.

■ b5-09 PI Output Level Selection

Setting	Description
0	Normal Output (direct acting) (<i>factory default</i>)
1	Reverse Output (reverse acting)

Normally, the output of the PI function causes an increase in motor speed whenever the measured feedback is below the setpoint. This is referred to as direct acting response. However, if b5-09 = “1: Reverse Output,” the output of the PI function causes the motor to slow down when the feedback is below the setpoint. This is referred to as reverse acting response.

■ b5-10 PI Output Gain Setting

Setting Range: 0.0 to 25.0

Factory Default: 1.0

Applies a multiplier to the output of the PI function. Using the gain can be helpful when the PI function is used to trim the Speed Command. Increasing b5-10 causes the PI function to have a greater regulating affect on the speed command.

■ b5-12 PI Feedback Reference Missing Detection Selection

Setting	Description
0	Disabled (<i>factory default</i>)
1	Alarm
2	Fault

Loss of feedback can cause problems to a PI application. The iQpump drive can be programmed to turn on a digital output whenever a loss of feedback occurs. Feedback Loss Detection is turned on by b5-12. When b5-12 = “1: Alarm,” the iQpump drive acknowledges the loss of feedback without stopping or turning on the fault output (MA-MB). If b5-12 = “2: Fault,” the iQpump drive coasts to a stop and turns on the fault output if the feedback is determined to be lost.

■ b5-13 PI Feedback Loss Detection Level

Setting Range: 0 to 100%

Factory Default: 0%

■ b5-14 PI Feedback Loss Detection Time

Setting Range: 0.0 to 25.0 sec

Factory Default: 1.0 sec

The iQpump drive interprets feedback loss whenever the feedback signal drops below the value of b5-13 and stays below that level for at least the time set into b5-14. See [Figure 5.17](#) for timing details.

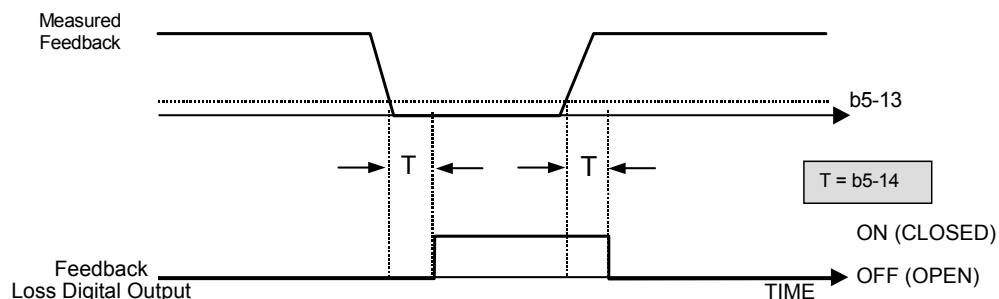

Figure 5.17 Loss of PI Feedback Feature

■ b5-17 PI Accel/Decel Time

Setting Range: 0.0 to 25.5 sec

Factory Default: 0.0 sec

This is a soft start function that is applied to the PI setpoint analog input. Instead of having nearly instantaneous changes in signal levels, there is a programmed ramp applied to level changes. When changing setpoints, the error can be limited by gradually ramping the setpoint through the use of parameter b5-17.

◆ b8 Energy Savings

The energy savings function improves overall system operating efficiency by operating the motor at its highest efficiency. This is accomplished by continuously monitoring the motor load and adjusting the motor terminal voltage so that the motor always operates near its rated slip frequency. A motor is most efficient when operating near rated slip conditions.

■ b8-01 Energy Savings Selection

Setting	Description
0	Disabled (<i>factory default</i>)
1	Enabled

When the Energy Savings function is enabled (b8-01 = “1: Enabled”), the iQpump drive reduces the output voltage to the motor below the voltage value specified by the programmed V/f pattern whenever the motor load is light. Since torque is reduced during this voltage reduction, the voltage has to return to normal levels when the load returns. The energy savings is realized through improved motor efficiency. The reduced output voltage causes increased rotor slipping even with a light load. A motor is most efficient when operating fully loaded (i.e. operating at rated slip).

■ b8-04 Energy Saving Coefficient Value

Setting Range: 0.0 to 655.0
Factory Default: Model Dependent

Parameter b8-04 is used in maximizing motor efficiency. The factory setting will be iQpump drive capacity dependant but can be adjusted in small amounts while viewing the kW monitor (U1-08) and running the iQpump drive to minimize the output kW. A larger value typically results in less voltage to the motor and less energy consumption. Too large a value will cause the motor to stall.

■ b8-05 Power Detection Filter Time

Setting Range: 0 to 2000 ms
Factory Default: 20 ms

The Energy Saving function will search out the lowest output voltage in order to achieve minimum output power usage. Parameter b8-05 determines how often the output power (kW) is measured and the output voltage is adjusted.

■ b8-06 Search Operation Voltage Limit

Setting Range: 0 to 100%
Factory Default: 0%

Once Energy Savings is enabled and the optimal energy saving coefficient value has been set, the programmer can have the iQpump drive further search out the proper voltage to achieve the lowest output power by making minute changes to the output voltage and measuring the output power every b8-05 ms. Parameter b8-06 sets limits to the range over which the voltage will be adjusted in order to minimize the power output. Settings too large a value may allow the motor to stall if the load is applied abruptly.

If b8-06 = 0, then the optimum voltage search operation is disabled (but not Energy Savings itself).

◆ C1 Accel/Decel

- **C1-01 Acceleration Time 1**
- **C1-02 Deceleration Time 1**
- **C1-03 Acceleration Time 2**
- **C1-04 Deceleration Time 2**
- **C1-05 Acceleration Time 3**
- **C1-06 Deceleration Time 3**

Setting Range: 0.0 to 6000.0 sec
 Factory Default: C1-01 and C1-02, 25.0 sec
 C1-03 and C1-04, 10.0 sec
 C1-05 and C1-06, 50.0 sec

C1-01 (Acceleration Time 1) sets the time to accelerate from zero to maximum speed (E1-04). C1-02 (Deceleration Time 1) sets the time to decelerate from maximum speed to zero. C1-01 and C1-02 are the factory default active accel/decel "pair." Another accel/decel pair (C1-03 and C1-04) exists that can be activated by a multi-function digital input (H1-0x = 7), or specified by a switch over frequency as programmed in parameter C1-11.

The C1-05 (Acceleration Time 3) and C1-06 (Deceleration Time 3) are used during the multiple pumping operation. Refer to P3-12 (in the Programming Manual) for further description.

◆ d2 Reference (Speed Command) Limits

■ d2-01 Frequency Reference Upper Limit

Setting Range: 0.0 to 110.0%
 Factory Default: 100.0%

■ d2-02 Frequency Reference Lower Limit

Setting Range: 0.0 to 110.0%
 Factory Default: 0.0%

The use of parameters d2-01 and d2-02 places limitations on the speed command that the iQpump drive will accept. The parameters are set in units of percentage of the maximum frequency (E1-04) and provide limits on any remote speed command input. By entering upper or lower frequency limits, the iQpump drive programmer can prevent operation of the iQpump drive above or below levels that may cause resonance, equipment damage or discomfort (see also parameter d3-0X). For example, limits may be needed to prevent low speed operation of: Cooling tower fans with gear boxes, pumps with pressure dependent seals, or AHUs with minimum delivery requirements.

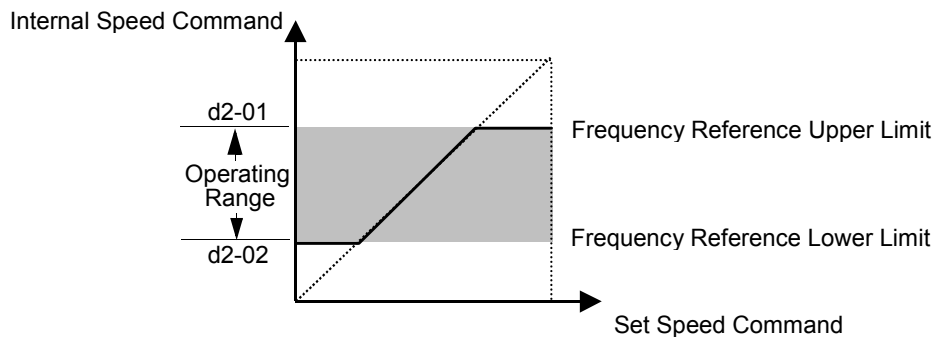

Figure 5.18 Frequency Reference Upper and Lower Limit Effects on the Speed Command

5.1 iQpump Basic Programming Parameters

■ d2-03 Master Speed Reference Lower Limit

Setting Range: 0.0 to 110.0%

Factory Default: 0.0%

Unlike Frequency Reference Lower Limit (d2-02) which will affect the speed command no matter where it is sourced from (i.e. analog input, preset speed, jog speed, etc.), the Master Speed Reference Lower Limit (d2-03) sets a low speed threshold that will only affect the analog input that is the active master speed frequency (as determined by parameter H3-13 and H3-09). This parameter allows a minimum speed to be programmed for the master reference while allowing a lower speed to be set as a jog reference. If the speed commanded by the active master speed frequency is below the setting of d2-03, then the iQpump drive will operate at the speed specified by d2-03.

◆ d3 Jump Frequencies

■ d3-01 Jump Frequency 1 d3-02 Jump Frequency 2 d3-03 Jump Frequency 3

Setting Range: 0.0 to 200.0 Hz

Factory Default: 0.0 Hz

■ d3-04 Jump Frequency Width

Setting Range: 0.0 to 20.0 Hz

Factory Default: 1.0 Hz

In order to avoid continuous operation at a speed that causes resonance in driven machinery, the iQpump drive can be programmed with jump frequencies that will not allow continued operation within specific frequency ranges. If a speed is commanded that falls within a dead band, or Jump Frequency, the iQpump drive will clamp the frequency reference just below the dead band and only accept higher speed commands when the commanded speed rises above the upper end of the dead band, for increasing references. Similarly, the iQpump drive will clamp the frequency reference just above the dead band and only accept lower speed commands when the command speed falls below the lower end of the dead band, for decreasing references.

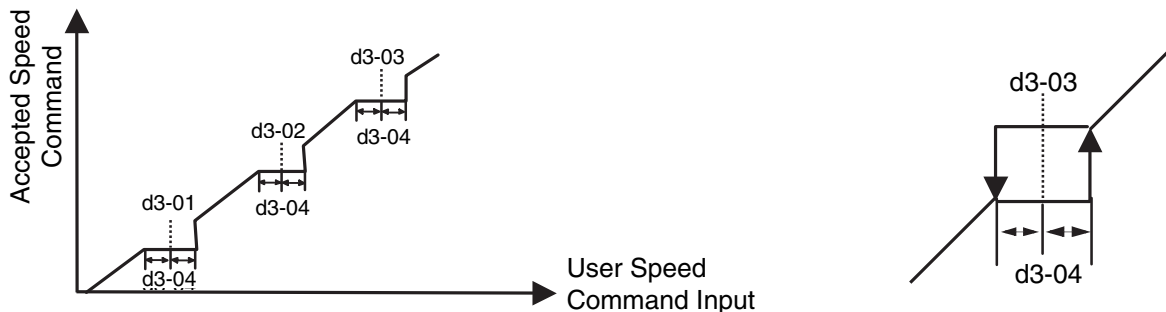

Figure 5.19 Jump Frequency Characteristics

Setting the center point of the dead band with the d3-01 through d3-03 parameters and setting the width of the dead band with parameter d3-04 determines the dead band characteristics. The programmer can set up to three Jump Frequencies. If multiple Jump Frequencies are programmed the following rule applies:

$$d3-01 \leq d3-02 \leq d3-03$$

◆ E1 V/f Pattern

■ E1-01 Input Voltage Setting

Setting Range: 155.0 V to 255.0 V (208 V/240 V Models)
310.0 V to 510.0 V (480 V Models)

Factory Defaults: 208.0 V (208 V Models)
240.0 V (240 V Models)
480.0 V (480 V Models)

Set the Input Voltage parameter (E1-01) to the nominal voltage of the connected AC power supply. This parameter adjusts the levels of some protective features of the iQpump drive (i.e. Overvoltage, Stall Prevention, etc.). E1-01 also serves as the Maximum/Base Voltage used by the Preset V/Hz curves (E1-03 = 0 to D).

■ E1-03 V/f Pattern Selection

Table 5.2

Setting	Description
0	50 Hz
1	60 Hz Saturation
2	50 Hz Saturation
3	72 Hz
4	50 Hz VT1
5	50 Hz VT2
6	60 Hz VT1
7	60 Hz VT2
8	50 Hz HST1
9	50 Hz HST2
A	60 Hz HST1
B	60 Hz HST2
C	90 Hz
D	120 Hz
E	180 Hz (invalid - OPE2 fault will occur)
F	Custom V/f (factory default, with parameter values per setting 1)
FF	Custom w/o limit

The iQpump drive operates utilizing a set V/f pattern to determine the appropriate output voltage level for each commanded speed. There are 14 different preset V/f patterns to select from with varying voltage profiles, saturation levels (frequency at which maximum voltage is reached), and maximum frequencies.

There are also settings for Custom V/f patterns that will allow the programmer to manually set (“Customize”) the V/f pattern using parameters E1-04 through E1-13.

Using parameter E1-03, the programmer can select one of the preset V/f patterns or chose between a custom V/F pattern with an upper voltage limit (E1-03 = “F: Custom V/F”) and a custom V/f pattern without a voltage limit (E1-03 = “FF: Custom w/o limit”).

5.1 iQpump Basic Programming Parameters

Table 5.3 Preset V/f Patterns

Specifications		E1-03	V/f Pattern *1		Specifications	E1-03	V/f Pattern *1	
General-purpose	50Hz	0		High Starting Torque *2	50Hz	8		
	60Hz Saturation	1			High Starting Torque 2	9		
	50Hz Saturation	2			High Starting Torque 1	A		
					High Starting Torque 2	B		
	72Hz	3			90Hz	C		
Variable Torque	50Hz	Variable Torque 1	4	High Speed Operation	120Hz	D		
		Variable Torque 2	5					
	60Hz	Variable Torque 1	6					
		Variable Torque 2	7					

If one of the custom V/f patterns is selected, then parameters E1-04 through E1-13 will determine the V/F pattern.

Table 5.3 is for 240V class units only. For 480V class units multiply the voltage value by 2.

Important: When a factory Initialization is performed, the setting of E1-03 is unaffected but the settings of E1-04 through E1-13 are returned to their factory default settings.

■ E1-04 Maximum Output Frequency

Setting Range: 0.0 to 120.0 Hz

Factory Default: 60.0 Hz

■ E1-05 Maximum Output Voltage

Setting Ranges: 0.0 to 255.0 V (240 V Models)
0.0 to 510.0 V (480 V Models)

Factory Defaults: 230.0 V (240 V Models)
460.0 V (480 V Models)

■ E1-06 Base Frequency

Setting Range: 0.0 to 200.0 Hz

Factory Default: 60.0 Hz

■ E1-07 Mid Output Frequency A

Setting Range: 0.0 to 200.0 Hz

Factory Default: 3.0 Hz

■ E1-08 Mid Output Voltage A

Setting Ranges: 0.0 to 255.0 V (240 V Models)

0.0 to 510.0 V (480 V Models)

Factory Defaults: 17.2 V (240 V Models)

34.5 V (480 V Models)

■ E1-09 Minimum Output Frequency

Setting Range: 0.0 to 200.0 Hz

Factory Default: 1.5 Hz

■ E1-10 Mid Output Voltage

Setting Ranges: 0.0 to 255.0 V (240 V Models)

0.0 to 510.0 V (480 V Models)

Factory Defaults: 10.3 V (240 V Models)

20.7 V (480 V Models)

■ E1-11 Mid Output Frequency B

Setting Range: 0.0 to 120.0 Hz

Factory Default: 0.0 Hz

■ E1-12 Mid Output Voltage B**E1-13 Base Voltage**

Setting Ranges: 0.0 to 255.0 V (240 V Models)

0.0 to 510.0 V (480 V Models)

Factory Defaults: 0.0 V (All Models)

To set up a custom V/f pattern, program the points shown in the diagram below using parameters E1-04 through E1-13. Be sure that the following condition is true: $E1-09 \leq E1-07 \leq E1-06 \leq E1-11 \leq E1-04$

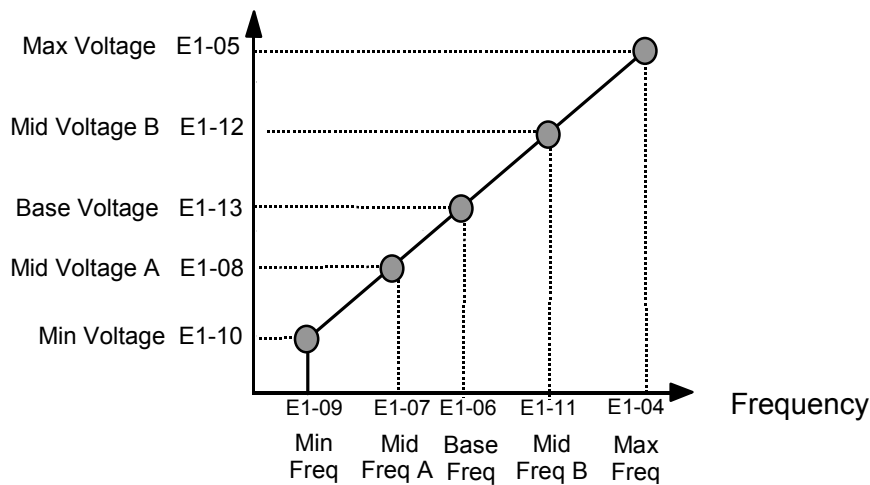

Figure 5.20 Custom V/f Pattern Programming Curve

Increasing the voltage in the V/f pattern increases the available motor torque. However, when setting a custom V/f pattern, increase the voltage gradually while monitoring the motor current, to prevent:

- iQpump drive faults as a result of motor over-excitation
- Motor overheating or excessive vibration

◆ E2 Motor Setup

■ E2-01 Motor Rated Current

Setting Range: 10% to 200%
 Factory Default: Model Dependent

The Motor Rated Current parameter (E2-01) is necessary information for the iQpump drive motor protection function. The motor overload protection parameter L1-01 is enabled by default. In addition, motor rated current is used by the torque compensation function to insure optimum torque production. Set E2-01 to the full load amps (FLA) value stamped on the motor's nameplate. During Auto-tuning, it is required for the operator to enter the motor rated current in parameter T1-04 on the Auto-Tuning menu. If the Auto-tuning operation completes successfully, the value entered into T1-04 will be also written into E2-01.

For applications employing a iQpump drive that is oversized for the motor, E2-01 may be set as low as 10% of the iQpump drive output current rating. The AMP value in E2-01, however, must always be greater than the "No Load Current" value in parameter E2-03 or an OPE02 error will be displayed.

■ E2-03 No Load Current

Setting Range: Model Dependent
 Factory Default: Model Dependent

Set E2-03 to the motor no-load current at rated voltage and rated frequency. Consult the motor manufacturer for the proper value if the no load current is not stated on the motor nameplate.

■ E2-04 Number of Motor Poles

Setting Range: 2 to 48
 Factory Default: 2

This parameter sets the number of motor poles used for no-flow detection function and for the calculation of RPM-related parameters.

◆ H3 Analog Inputs

■ H3-02 Terminal A1 Gain Setting

Setting Range: 0.0 to 1000.0%

Factory Default: 100.0%

■ H3-03 Terminal A1 Bias Setting

Setting Range: -100.0% to +100.0%

Factory Default: 0.0%

In order to have the iQpump drive properly interpret an analog input, it may be necessary to apply a gain and/or a bias to the signal. The analog inputs have a resolution of 10 bits (1024 steps). Using the factory default settings for the analog input's gain and bias, the 0-10 Vdc or 4-20 mA signal at the analog input will yield a 0-100% speed command span.

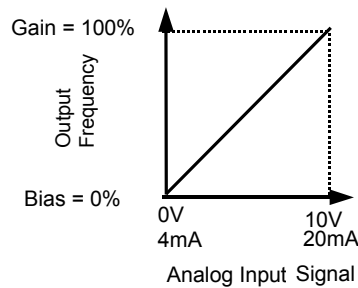

Figure 5.34 Output Frequency as Commanded Via Analog Input

If a different span of analog input signal is desirable, it will be necessary to adjust the gain, the bias, or both to allow the analog input level to generate the desired frequency command. Adjustment of the gain setting will change the speed command that is equivalent to the maximum analog input (10 Vdc or 20 mA). If, for instance, the gain is increased to 200%, then 10 Vdc or 20 mA will be equivalent to a 200% speed command and 5 Vdc or 12 mA will be equivalent to a 100% Speed Command. Since the iQpump drive output is limited by the maximum frequency parameter (E1-04), 0-5 Vdc or 4-12 mA will now be equivalent to 0-100% speed command span.

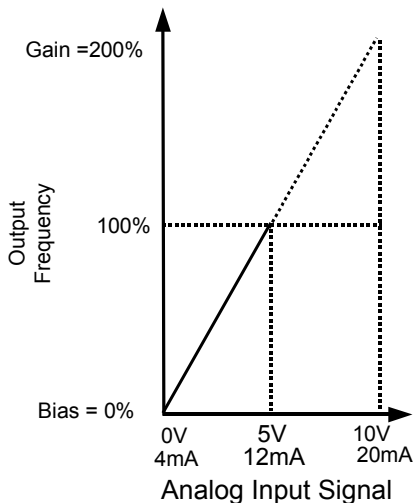

Figure 5.35 Output Frequency as Commanded via Analog Input with Increased Gain Setting

Adjustment of the bias setting will likewise adjust the speed command that is equivalent to the minimum analog input level (0 Vdc or 4 mA). If, for instance, the bias is set to -25%, then 0 Vdc or 4 mA will be equivalent to a -25% speed command. Since the minimum speed command is 0% an analog input of 2.5 to 10 Vdc or 8 to 20 mA will now be equivalent to 0-100% speed command span.

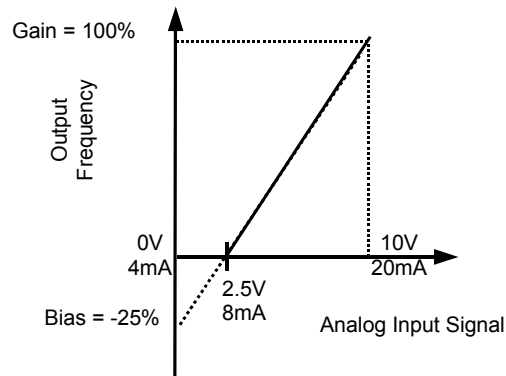

Figure 5.36 Output Frequency with Reduced Bias Setting

As a further example, for an inverse-acting speed command, set the bias = 100% and the gain = 0%. The minimum analog input level (0 Vdc or 4 mA) will produce a 100% speed command and the maximum analog input level (10 Vdc or 20 mA) will produce a 0% speed command.

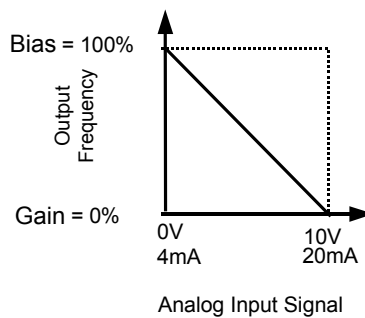

Figure 5.37 Output Frequency with Inverted Gain and Bias Settings

■ H3-08 Terminal A2 Signal Level

Setting	Description
0	0 - 10 Vdc
2	4 - 20 mA (factory default)
3	0 - 20 mA

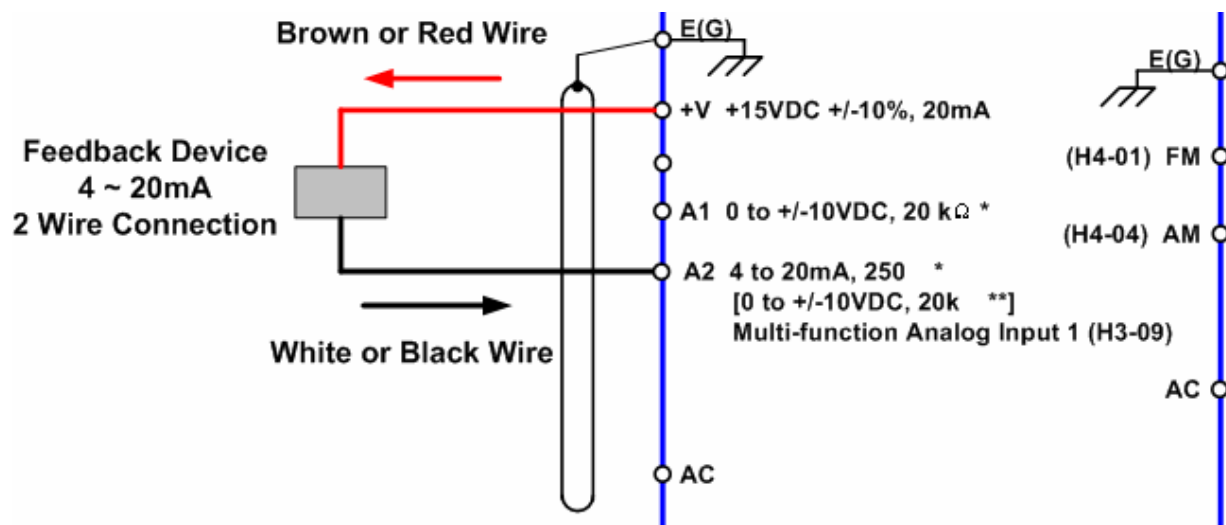

Figure 5.38 Connection of a 2-Wire 4~20 mA Feedback Device (H3-08 = 2)

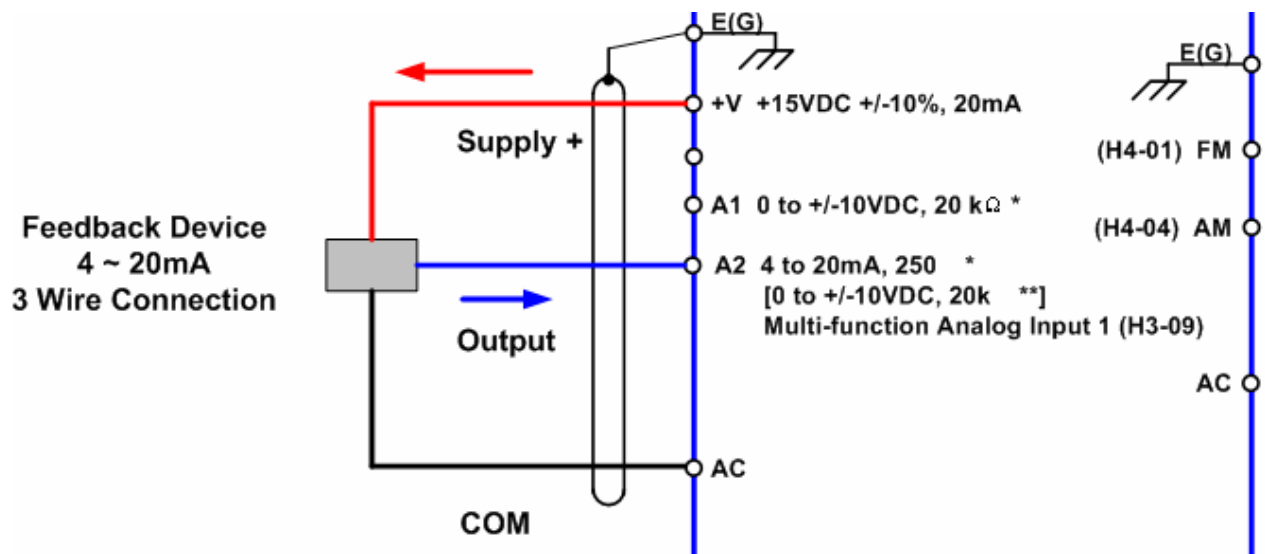

Figure 5.39 Connection of a 3-Wire 4~20 mA Feedback Device (H3-08 = 2)

The H3-08 parameter (Terminal A2 Signal Level) allows the programmer to specify the signal that will be applied to the A2 analog input. The A2 analog input can accept either a 0–10 Vdc or 4-20 mA signal as a reference. The iQpump drive also has a DIP switch (S1) on the removable terminal board that must be set for the proper reference signal into the A2 analog input. The S1-2 dip switch setting determines the internal resistance of the A2 input while parameter H3-08 determines how the iQpump drive interprets the measured signal.

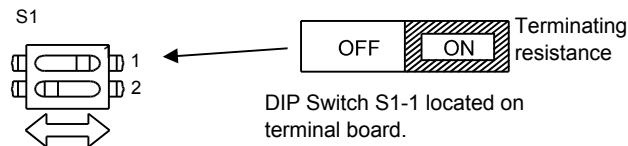
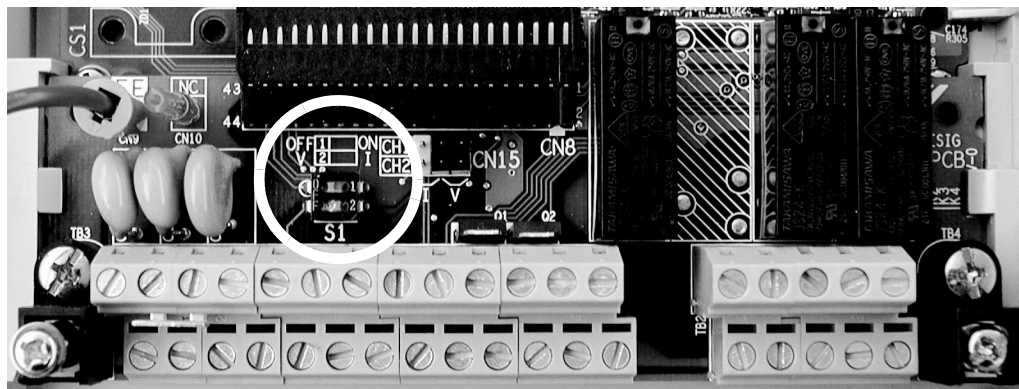

Figure 5.40 DIP Switch S1

Table 5.4 DIP Switch S1

Name	Function	Setting
S1-1	RS-485 and RS-422 terminating resistance	OFF: No terminating resistance ON: Terminating resistance of 110 Ω
S1-2	Input method for analog input A2	OFF: 0 to 10 V (internal resistance: 20 kΩ) ON: 4 to 20 mA (internal resistance: 250 Ω) (Default)

■ H3-09 Terminal A2 Function Selection

Setting	Description
0	Frequency Bias
2	Aux Reference
B	PI Feedback (<i>factory default</i>)
D	Frequency Bias 2
E	Motor Temperature
16	PI Differential
1F	Not Used

The A2 analog input can be programmed to perform many different functions. The setting of parameter H3-09 determines which of the following functions the A2 analog input will perform.

Function: Frequency Bias
Setting: 0

By setting H3-09 = “0: Frequency Bias,” the A2 analog input will serve as a bias signal to the A1 Speed Command. The effect of using A2 for a frequency bias is that the level of the A2 analog input will be summed with the level of the Speed Command analog input (A1). For example, if H3-02 = 100%, H3-03 = 0%, and the A2 analog input level is 1 Vdc, the Speed Command profile will look like the figure below. If A1 = 0 Vdc the Speed Command would be 10% of the programmed maximum frequency because A1 (0 Vdc) + A2 (1 Vdc) = 1 Vdc.

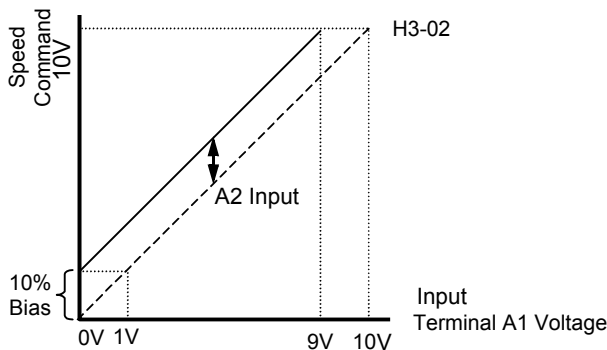

Figure 5.41 Effect of Frequency Bias Function on Speed Command

It should be noted that the bias applied by the A2 analog input functions differently than the level set by the H3-03. If both biases are used simultaneously they will sum together.

The level of the A1 analog input, as a percentage of the maximum input (either 10 Vdc or 20 mA), can be viewed by the U1-15 monitor. The level of the A2 analog input, as a percentage of the maximum input, can be viewed by the U1-16 monitor.

The bias applied by setting H3-09 = “0: Frequency Bias,” can be used in conjunction with the parameter bias H3-03. In that case the H3-03 bias is applied first which changes the slope of the Speed Command vs. Terminal A1 Voltage graph. Then the level of the A2 analog input is summed with the A1 analog input level, which in effect shifts the Speed Command vs. Terminal A1 Voltage graph upwards or downwards but does not change the slope of the line.

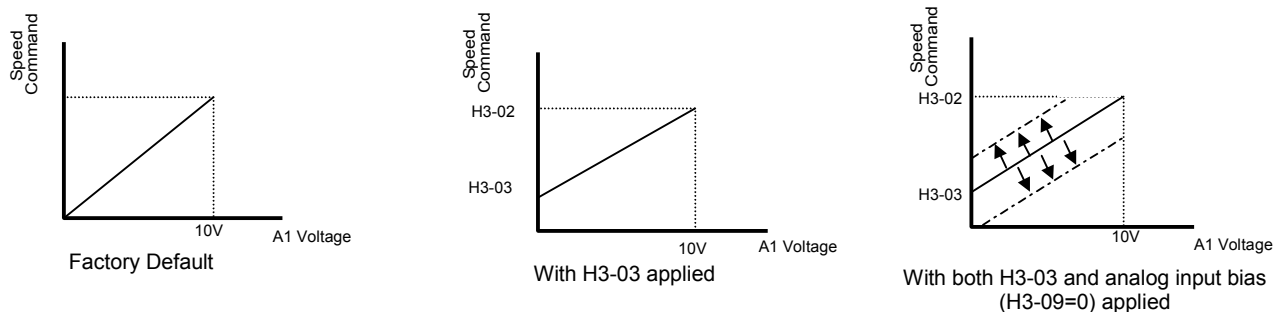

Figure 5.42 Frequency Bias Applied to Analog Speed Command

Function: Aux Reference
Setting: 2

In order for the A2 analog input to be used as the master Speed Command, parameter H3-09 must be set for Aux Reference (H3-09 = “2: Aux Reference”). Once A2 is configured as an auxiliary reference, it can be selected as the master Speed Command by setting H3-13 = “1: Main Fref TA2.” If H3-09 = 2, terminal A2 analog input will become the speed command when a digital input programmed for Multi-Step Ref 1 (H1-0x = 3) is selected by a contact closure.

Function: PI Feedback
Setting: B

Configuring the A2 analog input as PI Feedback (H3-09 = “B: PI Feedback”) is a requirement of setting the iQpump drive up for PI operation. The A2 analog input is the only source for feedback for PI operation though the setpoint can come from a number of different sources (refer to the section covering the PI parameters for more information regarding specifying the setpoint source. PI parameters are listed in section b5).

Parameters H3-10 (Terminal A2 Gain) and H3-11 (Terminal A2 Bias) can be used to configure the A2 analog input to match the signal from the Feedback Transmitter.

The U1-24 monitor (PI Feedback) can be used to check the PI Feedback level with the digital operator.

Function: Frequency Bias 2
Setting: D

By setting H3-09 = “D: Frequency Bias 2,” the A2 analog input will serve as a bias signal to the A1 Speed Command. This setting functions the same as a setting of H3-09 = 0: Frequency Bias.

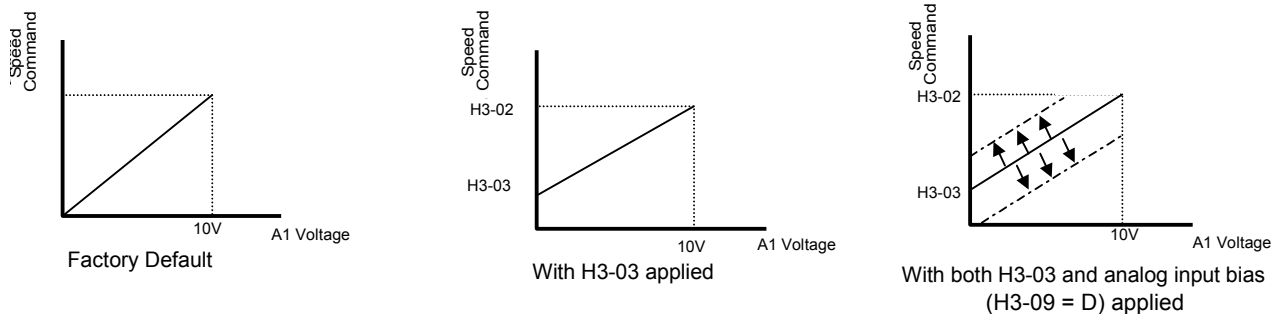

Figure 5.43 Frequency Bias 2 Applied to Analog Speed Command

Function: PI Differential
Setting: 16

Normal PI operation will adjust the iQpump drive output in order to match the measured feedback value to a desired setpoint. When PI is operated in the differential mode, however, the iQpump drive output is adjusted in order to maintain a desired differential between two feedback signals.

When the A2 analog input is configured as a PI Differential (H3-09 = “16: PI Differential”), the A1 analog input becomes the other PI Differential input. The desired differential is set by parameter b5-07 (PI Differential Setpoint) and can be set so that A2 is held less than A1 (b5-07 < 0) or A2 is held greater than A1 (b5-07 > 0).

When PI Differential operation is chosen, the A1 feedback level can be monitored by U1-24 (PI Feedback) and the A2 feedback level can be monitored by U1-53 (PI Feedback2).

Function: Not Used
Setting: 1F

When H3-09 = “1F: Not Used,” any signal applied to the A2 analog input will be ignored by the iQpump drive.

■ **H3-10 Terminal A2 Gain Setting**

Setting Range: 0.0 to 1000.0%
 Factory Default: 100.0%

■ **H3-11 Terminal A2 Bias Setting**

Setting Range: -100.0% to +100.0%
 Factory Default: 0.0%

5.1 iQpump Basic Programming Parameters

Parameters H3-10 and H3-11 perform the same function for the A2 analog input that parameters H3-02 and H3-03 perform for the A1 analog input. Please refer to the parameter description for H3-02 and H3-03 for information about H3-10 and H3-11.

These parameters could be used for final calibration of a factory or field installed pressure to electric transducer input connected to terminal A2 and AC. This field calibration may be needed if there is a job site variation from the typical 3 to 15 PSIG pneumatic signal input range.

■ H3-12 Analog Input Filter Time Constant

Setting Range: 0.00 to 2.00 sec

Factory Default: 0.30 sec

An analog input filter can be used to prevent erratic iQpump drive control when a “noisy” analog reference is used. Parameter H3-12 sets the time constant for a first order filter that will be applied to both the A1 and A2 analog inputs. The iQpump drive operation becomes more stable the longer the time programmed, but it becomes less responsive to rapidly changing analog signals.

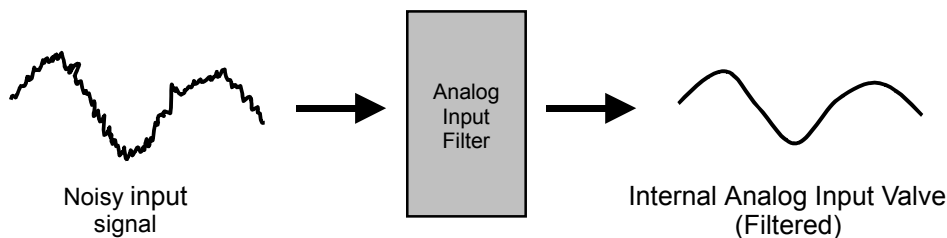

Figure 5.44 Analog Input Filter Time Constant Effect on “Noisy” Signal

■ H3-13 Master Frequency Reference Terminal Selection

Setting	Description
0	Main Fref = A1 (<i>factory default</i>)
1	Main Fref = A2

Parameter H3-13 allows the programmer to select which analog input will serve as the Speed Command input when “Terminals” are selected as the Auto Mode Speed source (b1-01 = “1: Terminals”), or Terminal is selected as the reference source for the Hand mode (b1-12 = “1: Terminals”). For the A2 analog input to be an effective selection for the H3-13 parameter, parameter H3-09 must be configured as Aux Reference (H3-09 = “2: Aux Reference”).

If H3-09 ≠ 2, then the A1 analog input will be used regardless of the setting of parameter b1-12.

◆ L2 Momentary Power Loss Ride-Thru Function

When momentary power loss recovery is enabled (L2-01 ≠ 0), a speed search is executed to catch the potentially spinning motor shaft. This speed search will occur regardless of the setting of b3-01 “Speed Search Selection.”

■ L2-01 Momentary Power Loss Detection Selection

Setting	Description
0	Disabled
1	PwrL Ride Thru t
2	CPU Power Active (<i>factory default</i>)

■ L2-02 Momentary Power Loss Ride-Thru Time

Setting Range: 0.0 to 25.5 sec
 Factory Default: Model Dependent

The iQpump drive allows different responses to momentary power losses. The setting of L2-01 determines whether the iQpump drive attempts to restart after a short loss of incoming AC power and for what length of time this capability remains active.

If L2-01 = “0: Disabled,” the iQpump drive detects a UV1 fault 15ms after power loss and automatic restarting is disabled. The iQpump drive cannot restart until the external run command is removed and the UV1 fault is reset.

If L2-01 = “1: PwrL Ride Thru t,” the iQpump drive restarts without the UV1 fault if power is returned within the time specified in L2-02, the Momentary Power Loss Ride-thru Time. During the power loss but before the fault trip, the digital operator will display a UV alarm. If L2-02 is set for a time longer than the control power supply can be sustained, a UV1 fault will not occur and the iQpump drive restarts upon the return of AC power. The time that the control power supply can be maintained varies with iQpump drive size. The larger the iQpump drive, the greater the potential ride-thru time.

If L2-01 = “2: CPU Power Active,” the iQpump drive ignores L2-02 and attempts a restart as long as the control power supply is still able to maintain a minimal voltage level. In effect, setting L2-01 = “2: CPU Power Active” (factory default) is programming the iQpump drive for maximum Power Loss Ride-thru. An equivalent setting is L2-01 = “1: PwrL Ride Thru t,” with L2-02 set to a time longer than the control power supply can be maintained after power is lost.

Note: The run command must be held during power loss for any power loss ride-thru capability to be possible. It is for this reason that 3-wire control is not recommended for use with the Momentary Power Loss function.

◆ L5 Fault Restart

■ L5-01 Number of Auto Restart Attempts

Setting Range: 0 to 10
 Factory Default: 0

■ L5-02 Auto Restart Operation Selection

Setting	Description
0	No Flt Relay (<i>factory default</i>)
1	Flt Relay Active

■ L5-03 Maximum Restart Time After Fault

Setting Range: 10.0 to 3600.0 sec
 Factory Default: 180.0 sec

All major faults will cause the iQpump drive to stop. For some faults it is possible to configure the iQpump drive to attempt a restart automatically. After the fault occurs, the iQpump drive baseblocks for the Maximum Restart Time After Fault programmed in L5-03. After the baseblock is removed the iQpump drive checks if a fault condition still exists. If no fault condition exists the iQpump drive will attempt to restart the motor. If the restart is successful, the iQpump drive performs a Speed Search (Regardless of the status of b3-01 “Speed Search Selection”) from the set speed command and the Auto Restart Attempts count is increased by one. Even if the restart fails the restart count is increased by one as long as the iQpump drive attempted to rotate the motor. The restart count will not accumulate if the restart is not attempted due to a continuing fault condition, (i.e. an OV fault). The iQpump drive waits the Maximum Restart Time After Fault (L5-03) before attempting another restart. This parameter is not applicable to Loss of Prime Fault.

5.1 iQpump Basic Programming Parameters

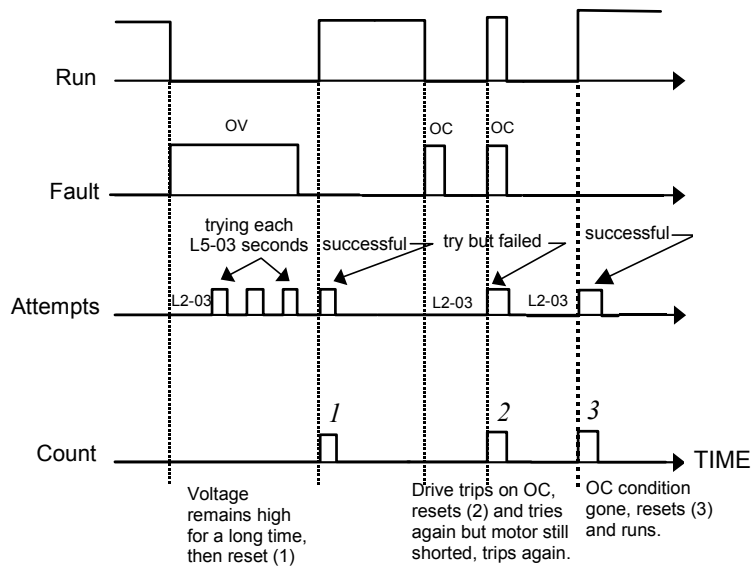

Figure 5.45 Automatic Restart Timing Diagram

The auto restart count is reset back to 0 if any of the following occur:

- No further faults for ten minutes after the last retry.
- The iQpump drives power is turned off (the iQpump drive must be without power long enough to let control power dissipate).
- The SHIFT/RESET key is pushed after the last reset attempt.

The setting of parameter L5-02 determines whether the fault output (MA-MB) will be closed during an auto restart attempt. The setting of L5-02 can be important when interfacing the iQpump drive with other equipment.

The following faults will allow the Auto Restart function to initiate:

- OC (Overcurrent)
- LF (Output Open Phase)
- PF (Input Phase Loss)
- PUF (DC Bus Fuse)
- OL1 (Motor Overload)
- OL3 (Overtorque)
- OL2 (Drive Overload)
- OV (DC Bus Overvoltage)
- GF (Ground Fault)
- UV1 (DC Bus Undervoltage)
- OH1 (Overheat)

In order for auto restart after a UV1 fault, Momentary Power Loss Ride-thru must be enabled (L2-01 = "1: PwrL Ride Thru t," or "2: CPU Power Active"). Setting H2-01 or H2-02 equal to "1E" configures a digital output as "Restart Enabled" to signal if an impending auto restart is possible.

◆ L6 Torque Detection

■ L6-01 Torque Detection Selection 1

Setting	Description
0	Disabled (<i>factory default</i>)
1	OL@SpdAgree - Alm
2	OL At Run - Alm
3	OL@SpdAgree - Flt
4	OL At Run - Flt
5	UL@SpdAgree - Alm
6	UL at Run - Alm
7	UL@SpdAgree - Flt
8	UL At Run - Flt

■ L6-02 Torque Detection Level 1

Setting Range: 0 to 300% of iQpump drive rated output current

Factory Default: 15% of iQpump drive rated output current

■ L6-03 Torque Detection Time 1

Setting Range: 0.0 to 10.0 sec

Factory Default 10.0 sec

The iQpump drive can be programmed to indicate when either an overtorque or an undertorque conditions exist. A digital output must be programmed for “Torque Detection,” (H2-01/H2-02 = “B: Trq Det 1 N.O.” or “17: Trq Det 1 N.C.”). A warning of an overtorque condition can indicate a jam and an undertorque condition can indicate a broken belt, no water in a pump, or other loss of load.

To configure Torque Detection requires the following decisions:

1. Do you wish to check for an overtorque condition or an undertorque condition?
2. Do you wish to check for the torque condition whenever the iQpump drive is running or only at speed agree? Nuisance detection during acceleration, when variable torques are normally required, can be avoided.
3. Do you want the iQpump drive to fault if the torque condition is detected or only alarm and continue operation?

The following table can help choose the proper setting for Torque Detection Selection 1 to get the wanted results.

Table 5.5 L6-01 Setting Choices

L6-01 Setting	Overtorque	Undertorque	Fault	Alarm	Always Detected	Only Detected @ Spd Agree
0	Torque Detection Disabled					
1	X			X		X
2	X			X	X	
3	X		X			X
4	X		X		X	
5*		X		X		X
6		X		X	X	
7		X				X
8		X			X	

*Suggested settings for Loss of Load indication

After selecting the proper detection scheme the Torque Detection Level (L6-02) must be specified. If the current level read by the output current transformers rises above (overtorque) or drops below (undertorque) this level, and remains there for at least the Torque Detection Time (L6-03), then the Torque Detection Function will change the state of any digital output configured for Torque Detection (H2-01/H2-02 = “B: Trq Det 1 N.O.” or “17: Trq Det 1 N.C.”).

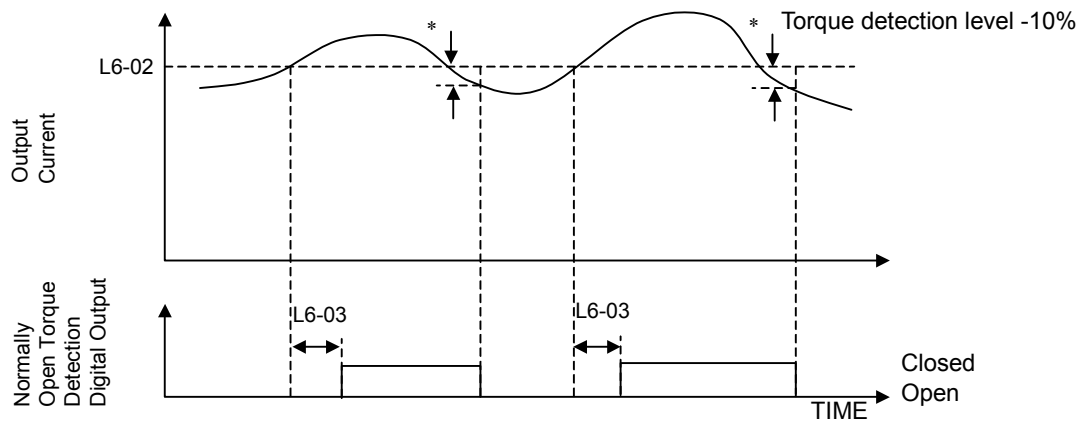

* When the output current drops below the Torque Detection Level by approximately 10% of the Drive's rated output current the digital output is reset.

Figure 5.46 Over Torque Detection

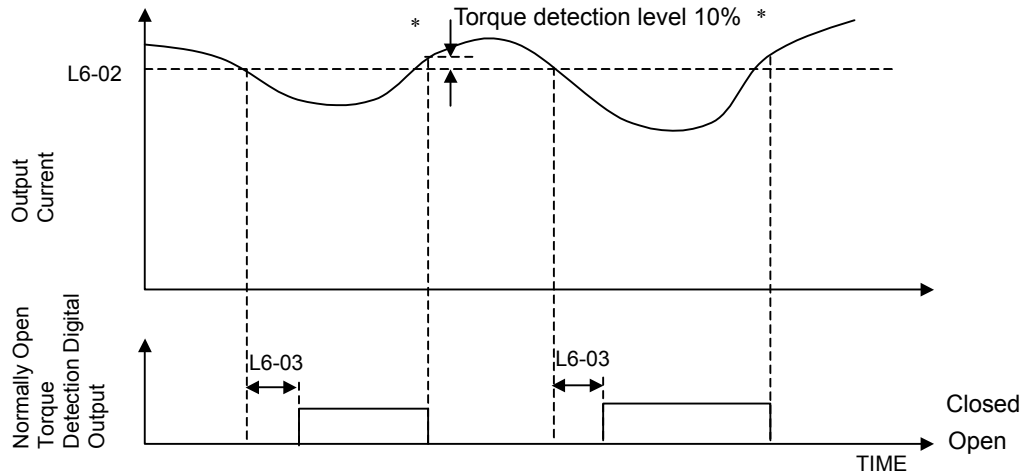

* When the output current rises above the Torque Detection Level by approximately 10% of the Drive's rated output current the digital output is reset.

Figure 5.47 Under Torque Detection

◆ L8 Hardware Protection

■ L8-01 Internal Dynamic Braking Resistor Protection Selection

Setting	Description
0	Not Provided (<i>factory default</i>)
1	Provided

This parameter is not applicable for iQpump drive operation.

■ L8-02 Overheat Pre-Alarm Level

Setting Range: 50 to 130°C

Factory Default: 95°C

■ L8-03 Overheat Pre-Alarm Operation Selection

Setting	Description
0	Ramp to Stop (Decel Time C1-02)
1	Coast to Stop
2	Fast-Stop (Decel Time C1-09)
3	Alarm Only
4	OH Alarm and Reduce (<i>factory default</i>)

The iQpump drive is capable of warning the operator of an impending heatsink over-temperature fault via an OH pre-alarm. The level at which the pre-alarm will activate is determined by the setting of parameter L8-02. Measurement of the heatsink temperature is done with several strategically mounted thermistors. If any of the heatsink thermistors measure a temperature in excess of the setting of L8-02, the iQpump drive will fault (OH2) and either: ramp to stop using the C1-02 deceleration rate (L8-03 = “0: Ramp to Stop”), coast to stop (L8-03 = “1: Coast to Stop”), ramp to stop using the C1-09 fast stop deceleration rate (L8-03 = “2: Fast-Stop”), alarm (OH) and continue running (L8-03 = “3: Alarm Only”), alarm (OH) and continue running but at a reduced speed (L8-03 = “4: Alarm & Reduce”). If L8-03 = 4: Alarm and Reduce, the iQpump drive will continue to run but will reduce the speed to the level determined by parameter L8-19. Refer to the description for parameter L8-19.

If a digital output is configured for OH Prealarm (H2-01 = “20: OH PreAlarm”), it will close whenever the heatsink temperature is greater than the L8-02 level no matter what the setting is of L8-03.

■ L8-05 Input Phase Loss Protection <0033>

Setting	Description
0	Disabled
1	Enabled (<i>factory default</i>)

The input phase loss detection circuit monitors the DC bus current ripple and activates when one of the input phases is lost. The detection circuit calculates the maximum and minimum values of the DC bus voltage in one second intervals, and compares the difference (ΔV) between these values with an internal detection level. If ΔV reaches or exceeds the detection level, after 0.5 second, the input phase loss is detected; a PF fault occurs and the motor coasts to a stop.

Input phase loss detection is disabled in the following cases:

- A Stop command is input
- Magnetic Contactor (MC) shuts OFF
- CPU A / D converter fault (CPF5)
- During deceleration
- Output current $\leq 30\%$ of Inverter rated current

■ L8-06 Input Phase Loss Detection Level

Setting Range: 0.0 to 25.0% of iQpump drives OV Trip point

Factory Default: 7.5%

The iQpump drive checks for a lost input phase by monitoring the DC Bus voltage ripple. After an initial delay of approximately 12 seconds, the iQpump drive will sample the DC BUS voltage every 1.28 seconds to determine the minimum and maximum voltage readings. The difference between the minimum and maximum voltage is averaged over ten consecutive scans. If this “averaged” value is greater than the trip level as determined by L8-06 (L8-06 x 400 for 200 volt class iQpump drives; L8-06 x 800 for 400 volt class iQpump drives) the iQpump drive shuts down and displays “PF,” an input phase loss fault.

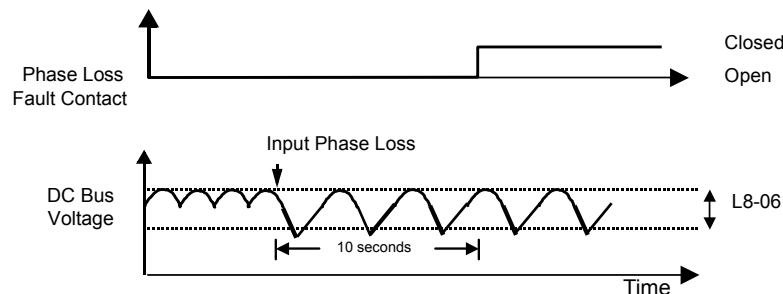

Figure 5.48 Input Phase Loss Detection Diagram

5.1 iQpump Basic Programming Parameters

■ L8-07 Output Phase Loss Protection <0033>

Setting	Description
0	Disabled
1	Enabled (<i>factory default</i>)

The output phase loss detection circuit monitors the DCCT and activates when one or more of the output phases are lost. The detection circuit calculates the RMS current value (I_{RMS}) for each of the phases and compares it with an internal output detection level. If I_{RMS} decreases to or below the detection level for 10 seconds, an output phase loss (LF) fault occurs and the motor coasts to a stop.

■ L8-09 Output Ground Fault Detection Selection

Setting	Description
0	Disabled
1	Enabled (<i>factory default</i>)

The iQpump drive has a ground fault detection circuit that activates when the current to ground exceeds 50% of the iQpump Drive's rated output current. The current to ground is determined by comparing the measured current on each of the output phases. If the current to ground is determined to be above 50% of the Drive's rated output current the digital operator will display a GF and the iQpump Drive will coast to stop.

■ L8-10 Heatsink Cooling Fan Operation Selection

Setting	Description
0	Fan On-Run Mode (<i>factory default</i>)
1	Fan Always On

Refer to L8-11 description.

■ L8-11 Heatsink Cooling Fan Operation Delay Time <0033>

Setting Range: 0 to 300 sec

Factory Default: 300 sec

Parameters L8-10 and L8-11 allow the iQpump drive programmer to customize the heatsink cooling fan operation. Parameter L8-10 determines whether the cooling fans are always ON whenever the iQpump drive is powered (L8-10 = "1: Fan Always On") or if the cooling fans are only ON when the iQpump drive is in a Run condition (L8-10 = "0: Fan On-Run Mode").

Parameter L8-11 is a delayed OFF for the cooling fan if L8-10 = "0: Fan On-Run Mode". When the cooling fans are set to turn OFF is when either the Run command is removed or the drive is in baseblock. The iQpump parameter L8-11 will cause the fans to continue cooling the iQpump drive for the amount of time programmed into L8-11 after the Run command is actually removed or baseblocked enabled. The iQpump drive can be programmed to allow the cooling fan to run for up to 5 minutes (factory default) after the run command is removed or baseblock enabled.

Both parameters are intended to extend fan life while still providing sufficient cooling for proper iQpump drive operation.



Figure 5.49 Heatsink Cooling Fan Operation Timing Diagram

■ L8-19 Overheat Frequency Reference Reduction Level

Setting Range: 0.0 to 100.0% of maximum frequency

Factory Default: 20.0% of maximum frequency

When the heatsink temperature reaches the OH Pre-alarm level (L8-02) and the Overheat Pre-Alarm Operation Selection parameter is set for Alarm and Reduce (L8-03 = “4: OH Alarm & Reduce”), the L8-19 parameter sets the amount of speed decrease that will be applied to the Speed Command in order to lower the heatsink temperature. The decrease in speed will lower the current being switched and conducted by the heat producing output transistors of the iQpump drive.

Parameter L8-19 is set in percentage of maximum frequency (E1-04).

◆ o1 Monitor Configuration

■ o1-01 User Monitor Selection

Setting Range: 6 to 94

Factory Default: 6

Setting	Description
6	Output Voltage (<i>factory default</i>)
7	DC Bus Voltage
8	Output Power
10	Input Terminal Status
11	Output Terminal Status
12	Drive Operation Status
13	Cumulative Operation Time
14	Software Number
15	Terminal A1 Input Voltage
16	Terminal A2 Input Voltage
18	Motor Secondary Current (Iq)
20	Output Frequency After Soft Start
24	PI Feedback Value
28	CPU Number
34	First Parameter Causing an OPE
36	PI Input
37	PI Output
38	PI Setpoint
39	Memobus Communication Error Code
40	Heatsink Cooling Fan Operation Time
90	Pump Setpoint
91	Pump Feedback
92	Pump Status
93	Total Setpoint Compensation
94	Motor Speed

■ o1-02 Power-On Monitor

Setting	Description
1	Frequency Reference (<i>factory default</i>)
2	Output Frequency
3	Output Current
4	User Monitor (set by o1-01)

When the iQpump drive is powered up, three monitors are displayed on the digital operator. The first and largest monitor is the “Power-On” monitor. The factory default “Power-On monitor” is Speed Command (U1-01). Below the Speed Command monitor are the next two sequential monitors, Output Frequency (U1-02) and Output Current (U1-03). Pressing the INCREASE key once scrolls the monitors to show the User Monitor as selected by o1-01. The factory default for o1-01 is the Output Voltage monitor (U1-06).

The active monitor displayed when the iQpump drive is powered on can be changed to either be U1-01 (Speed Command), U1-02 (Output Frequency), U1-03 (Output Current), or the User Monitor. Whichever monitor is selected as the Power-On top monitor, the two monitors displayed below it are the next two sequential monitors. See example below.

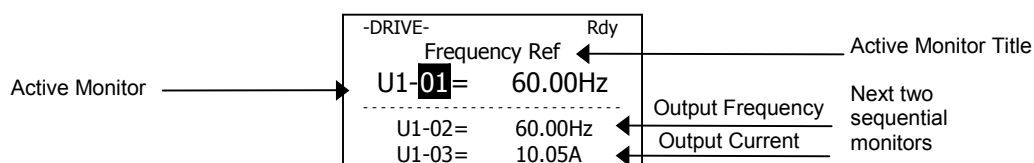

For example, if the iQpump drive needs to display the Elapsed Timer as the Power-On monitor, then o1-01 must be set to “13” and o1-02 must be set to “4.” The next time iQpump drive power is cycled, the digital operator displays U1-13 (Elapsed Time), U1-14 (Flash ID), and U1-15 (Term AI Level).

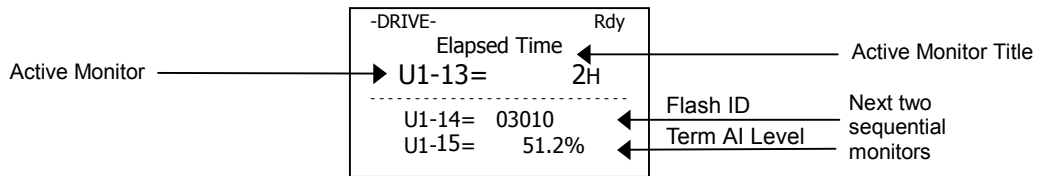

■ o1-05 LCD Contrast Adjustment

Setting Range: 1, 3 or 5
 Factory Default: 3

The contrast setting of the LCD display of the digital operator can be adjusted by the setting of parameter o1-05. The higher the number programmed into o1-05, the darker the background will become. Set o1-05 to the value that makes the LCD the easiest to view at the normal viewing distance and angle.

■ o1-06 User Monitor Selection Mode

Setting	Description
0	3 Mon Sequential
1	3 Mon Selectable (factory default)

■ o1-07 Second Line User Monitor

Setting Range: 1 to 94
 Factory Default: 2

■ o1-08 Third Line User Monitor

Setting Range: 1 to 94
 Factory Default: 91

Normally the monitors shown directly below the active monitor are the next two sequential monitors. If o1-06 (User Monitor Selection Mode) is set to “1: 3 Mon Selectable,” those two monitors are locked as specified by parameters o1-07 and o1-08 and will not change as the top parameter is scrolled with the INCREASE and DECREASE keys.

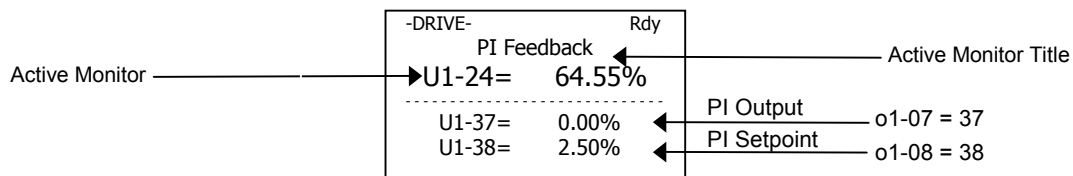

◆ o2 Key Selections

■ o2-06 Operation Selection when Digital Operator is Disconnected

Setting	Description
0	Disabled
1	Enabled (<i>factory default</i>)

■

Leaving o2-06 enabled will cause the iQpump drive to fault, when the digital operator is removed, even if it's not outputting to the motor. The reset key on the digital operator will need to be pressed after reconnecting the digital operator to reset the fault and continue normal operation.

If o2-06 = "0: Disabled" then the iQpump drive will not fault if the digital operator is disconnected, but the iQpump drive will discontinue motor operation. If full iQpump drive operation is required while the digital operator is removed set o2-06 = "0: Disabled" and o2-15 = "0: Disabled" (Hand Key Function). If both o2-06 and o2-15 are disabled then the digital operator can be disconnected without disturbing iQpump drive operation.

■ o2-07 Cumulative Operating Time Setting

Setting Range: 0 to 65535 hours

Factory Default: 0 hours

■ o2-08 Cumulative Operation Time Selection

Setting	Description
0	Power-On Time
1	Running Time (<i>factory default</i>)

The iQpump drive features an Elapsed Timer monitor that records in units of hours. The Elapsed Timer monitor is U1-13. Parameter o2-08 programs this function to either accumulate elapsed hours based on time the iQpump drive is powered (o2-08 = "0: Power-On Time") or time the iQpump drive is running (o2-08 = "1: Running Time"). The iQpump drive is considered "running" anytime there is an active run command or when the iQpump drive is outputting voltage (i.e. including during deceleration).

-DRIVE-	
Elapsed Time	
U1-13 = 0H	
U1-14 =	03010
U1-15 =	34.1%

Parameter o2-07 allows manual adjustment of the Elapsed Timer, primarily to accommodate maintenance or control board replacement in the event of damage. To reset the Elapsed Timer back to zero, set o2-07 = 0.

◆ o3 Digital Operator Copy Function

■ o3-01 Copy Function Selection

Setting	Description
0	COPY SELECT (<i>factory default</i>)
1	INV → OP READ
2	OP → INV WRITE
3	OP ↔ INV VERIFY

Note: The copy function is disabled when serial communication is active.

■ o3-02 Read Allowed Selection

Setting	Description
0	Disabled (<i>factory default</i>)
1	Enabled

The digital operator has parameter COPY capabilities via built in non-volatile memory. The digital operator can READ all of the parameters in the iQpump drive and store them for later WRITE back to the iQpump drive or into an iQpump drive with the same product code and software number. In order to read the parameter values and store them in the digital operator, select o3-02 = "1: Enabled". If you attempt to READ the data, which overwrites any previously stored data, without first setting o3-02 = "1: Enabled," you will get the following error:

```

-ADV-

  PRE
  READ IMPOSSIBLE

```

After setting o3-02 = "1: Enabled," it is possible to store parameter values in the digital operator by setting o3-01 = 1 (INV→OP READ).

A successful READ of the parameter values will display:

```

-ADV-

  READ
  READ COMPLETE

```

An error may occur while saving the parameter values to the digital operator's memory. If an error is displayed, press any key to cancel the error display and return to parameter o3-01. Error displays and their meanings are covered in Chapter 6: Diagnostics and Troubleshooting of the P7 Users Manual (TM.iQp.01). To COPY parameter values into a Drive, set o3-01 = "2: OPÆ INV WRITE". During the writing of the parameter values into the iQpump drive the digital operator will display:

```

-ADV-

  COPY
  OP→INV COPYING

```

A successful COPY of the parameter values will display:

```

-ADV-

  COPY
  COPY COMPLETE

```

An error may occur while writing the parameter values to the Drive. If an error is displayed, press any key to cancel the error display and return to parameter o3-01. Error displays and their meanings are covered in Chapter 6: Diagnostics and Troubleshooting of the iQpump User Manual (TM.iQp.01).

It is possible to compare the parameter values stored in the digital operator with the parameter values currently in the iQpump drive by using the VERIFY function. This VERIFY function should not be confused with the "-VERIFY-" that is displayed on the digital operator when viewing the "Modified Constants" menu. To VERIFY the parameter values in the iQpump drive as compared with those stored in the digital operator, set o3-01 = "3: OP'INV VERIFY". During the comparing of the parameter values into the iQpump drive the digital operator will display:

5.1 iQpump Basic Programming Parameters

-ADV-
VERIFY
DATA VERIFYING

A successful VERIFY of the parameter values will display:

-ADV-
VERIFY
VERIFY COMPLETE

If all the parameter values stored in the digital operator do not match those programmed in the iQpump drive, the digital operator displays the following:

-ADV-
VYE
VERIFY ERROR

The digital operator will not display which parameters did not match, only that the verification found discrepancies in some parameter values.

Note: In order to properly use the COPY or VERIFY functions, the following iQpump drive specifications must be identical between the iQpump drive that the parameters were read from and the iQpump drive that the parameters are to be written to:

- Model Number (e.g. CIMR-P7U2015-107)
- Software Number (e.g. 30030 also known as FLASH ID)

Yaskawa offers DriveWizard™ software that can also READ, COPY, and VERIFY iQpump drive parameter values. DriveWizard™ lists all discrepancies between the iQpump drive and a pre-saved parameter file when verifying is performed.

To use DriveWizard first select o2-15 = “0: Disabled” and select o2-06 = “0: Disabled” then remove the digital operator/keypad and attach the DriveWizard cable in its place.

5.2 Pump Basic

◆ Parameter Overview — P1 Group

Table 5.6

Parameter No.	Modbus Address	Parameter Name Digital Operator Display	Description	Setting Range	Factory Setting	Menu Location	Page No.
P1-01	0600H	Pump Mode Pump Mode	Select type of control operation. 0: Drive Only (Simplex) 1: Drive + 1 Pump (Duplex) 2: Drive + 2 Pumps (Triplex)	0 to 2	0	Programming	—
P1-02 <0032>	0601H	System Units System Units	0: WC:InchOfWater 1: PSI:lb/SqrInch 2: GPM:Gallons/Min 3: F:DegFahrenheit 4: CFM:Cubic ft/Min 5: CMH:Cubic m/Hr 6: LPH:Liters/Hr 7: LPS:Liters/sec. 8: Bar:Bar 9: Pa:Pascals 10: C:DegCelsius 11: Ft: Feet <0032> 12: %: Percent	0 to 12	1	Pump Quick Setup	—
P1-03	0602H	Feedback Device Scaling Fb Dev Scaling	Scaling of feedback device in user units (P1-02 = 1, e.g. 150PSI). Digits 1 through 4 set the maximum feedback number. Digit 5 determines the number of decimal places. Digit 5 = 0: Number format is XXXX Digit 5 = 1: Number format is XXX.X Digit 5 = 2: Number format is XX.XX Digit 5 = 3: Number format is X.XXX Examples: 01000 = 1000 10300 = 300.0 25000 = 50.00 32000 = 2.000	1 to 36000 (system units P1-02)	00145	Pump Quick Setup	—

◆ P1 Pump Minimum Speed and No-Flow Detection

The iQpump controller can be programmed to operate the pump motor at a user set minimum speed and has three independent built-in functions to protect the pump against a no-flow condition.

The following sections describe each of these functions.

■ Set Minimum Pump Speed (P1-06)

The required minimum operating speed of the pump motor can be set with Parameter P1-06 Minimum Pump Frequency.

Table 5.7

Parameter No.	Modbus Address	Parameter Name Digital Operator Display	Description	Setting Range	Factory Setting	Menu Location	Page No.
P1-06 ◆	0605H	Minimum Pump Frequency Min. Pump Freq.	Minimum drive frequency when operated in the auto mode. Programmed value will limit minimum PID output. Minimum value has to be programmed to a value smaller than P3-09 and P3-10 when Drive is operating in the multiplex mode (P1-01).	0 to 120Hz	35.0Hz	Pump Quick Setup	—

◆ Denotes that parameter can be changed when the Drive is running.

5.2 Pump Basic

Example: 3600 RPM Pump Motor

Desired Operation: Minimum Speed is 2100 RPM

Solution: Program P1-06 to 35.0Hz ($2100 \div 3600 \times 60 \text{ Hz (E1-04)} = 35.0 \text{ Hz}$)

Example: 1800 RPM Pump Motor

Desired Operation: Minimum Speed is 1000 RPM

Solution: Program P1-06 to 35.0Hz ($1000 \div 1800 \times 60 \text{ Hz (E1-04)} = 33.3 \text{ Hz}$)

◆ P1 Loss of Prime Detection <0032>

■ P1-12, P1-14

The Loss of prime function can be used to detect a pump system **low suction** condition. The iQpump Controller continuously monitors pump motor current and output frequency while operating auto mode.

■ Enable Loss of Prime Function

Program **P1-14 Prime Loss Level** to low suction condition current level.

Guideline: Use 40% of the pump motor full load amp rating (Parameter E2-01)

■ Operation

If the iQpump Controllers' output frequency is at maximum (Parameter E1-04) and the pump motor output current level drops below **P1-14 Prime Loss Level** for the time programmed in **P1-12 Not Maintaining Set Point and Loss of Prime** the iQpump drive will fault and display "LOP".

Table 5.8

Parameter No.	Modbus Address	Parameter Name Digital Operator Display	Description	Setting Range	Factory Setting	Menu Location	Page No.
P1-12 ◆ <0032>	0107H	Not Maintaining Setpoint and Loss of Prime Time SetPoint-LOP Tim	Delay time before a Not Maintaining SetPoint or Loss of Prime Time fault occurs. Pump protection criteria specified in P1-11 or P1-14 must be met for the Drive to fault. The Drive will coast to a stop when a fault occurs. A value of 0 disables both Loss of Prime and Not Maintaining SetPoint faults.	0 to 3600 sec	60 sec	Pump Quick Setup	—
P1-14 ◆	0109H	Prime Loss Level Prime Loss Level	Used to detect loss of prime in the pump. If output current drops below this level for the time specified in P1-12 and the output frequency is at fmax, a "Loss Of Prime" fault occurs. The Drive will coast to a stop when a fault occurs.	0 to 1000.0 A	0.0 A	Pump Quick Setup	—

◆ Denotes that parameter can be changed when the Drive is running.

Note: Loss of prime function is only active when the maximum numbers of pumps defined by P1-01 are running at maximum frequency.

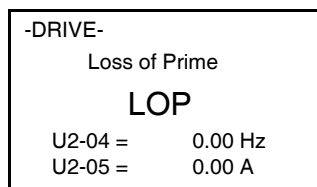

Figure 5.50 Loss of Prime (LOP) Fault

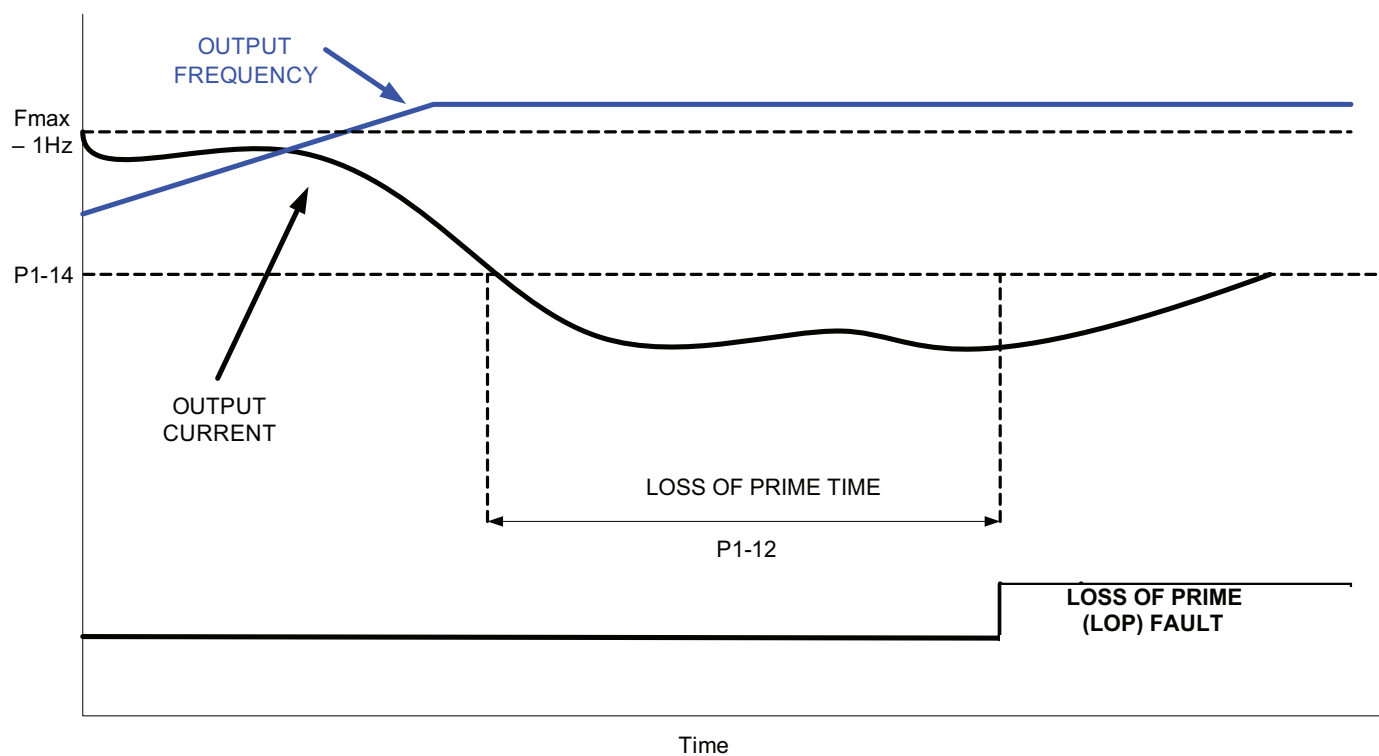

Figure 5.51 Loss of Prime (LOP) Fault

Note: Loss of prime function is only active when the maximum number of pumps defined by P1-01 running at maximum frequency.

Loss of prime function is only active in auto mode.

5.3 Pump Protection

◆ P2 Shutdown Pump System When Running at Low Speed (Sleep)

■ P2-01, P2-02, P2-03

To protect the pump from operating at very low speeds causing excessive pump wear the iQpump Controller offers a function to shutdown (Sleep) the pump system.

■ Select Signal to Monitor

The system level to monitor no-flow operation can be selected with parameter *P2-01 Sleep Level Type*:

Table 5.9

Parameter No.	Modbus Address	Parameter Name Digital Operator Display	Description	Setting Range	Factory Setting	Menu Location	Page No.
P2-01	060AH	Sleep Level Type Sleep Lvl Type	Sets the sleep type. 0: Output Frequency 1: Output Current 2: Feedback Note: Feedback depends on PID direction operation. Displays a “Sleep” Alarm when active.	0 to 2	0	Pump Quick Setup	—
P2-02 ◆	060BH	Sleep Level Sleep Level	Sleep activates when selected level (P2-01) reaches programmed sleep level for time specified in P2-03. The level type is determined by P2-01. A value of 0 disables this function. This function is only active during running while operating in auto mode. Display Units for Sleep Level P2-02 when P2-01 is programmed for the following: P2-01 = 0: >Display based on “Hz” P2-01 = 1: >Display based on “A” P2-01 = 2: >Display based on P1-02 Selection Note: When P2-01 is set for a value of 2, display units will be dependent on P1-02 setting.	0 to 6000.0	0.0	Pump Quick Setup	—
P2-03 ◆	060CH	Sleep Delay Time Sleep Delay Time	Delay time before Drive enters sleep mode when criteria is met as defined by parameter P2-02.	0 to 3600 sec	10 sec	Pump Quick Setup	—
◆ Denotes that parameter can be changed when the Drive is running.							

■ Setup Sleep Level (P2-02)

Sleep Detection level can be setup with *P2-02 Sleep Level*. The Sleep Level units for P2-02 depend on the selection of parameter P2-01 (System Units).

■ Sleep Function Based on Output Frequency (P2-01 = 0)

The iQpump Controller enters sleep mode when the output frequency falls below the level programmed in P2-02 for a time specified in P2-03.

Note: In order for the sleep function to become active the output frequency has to rise above the programmed level P2-02 first or above the Sleep Active Level (P2-20) when programmed to a value greater than 0.0 Hz.

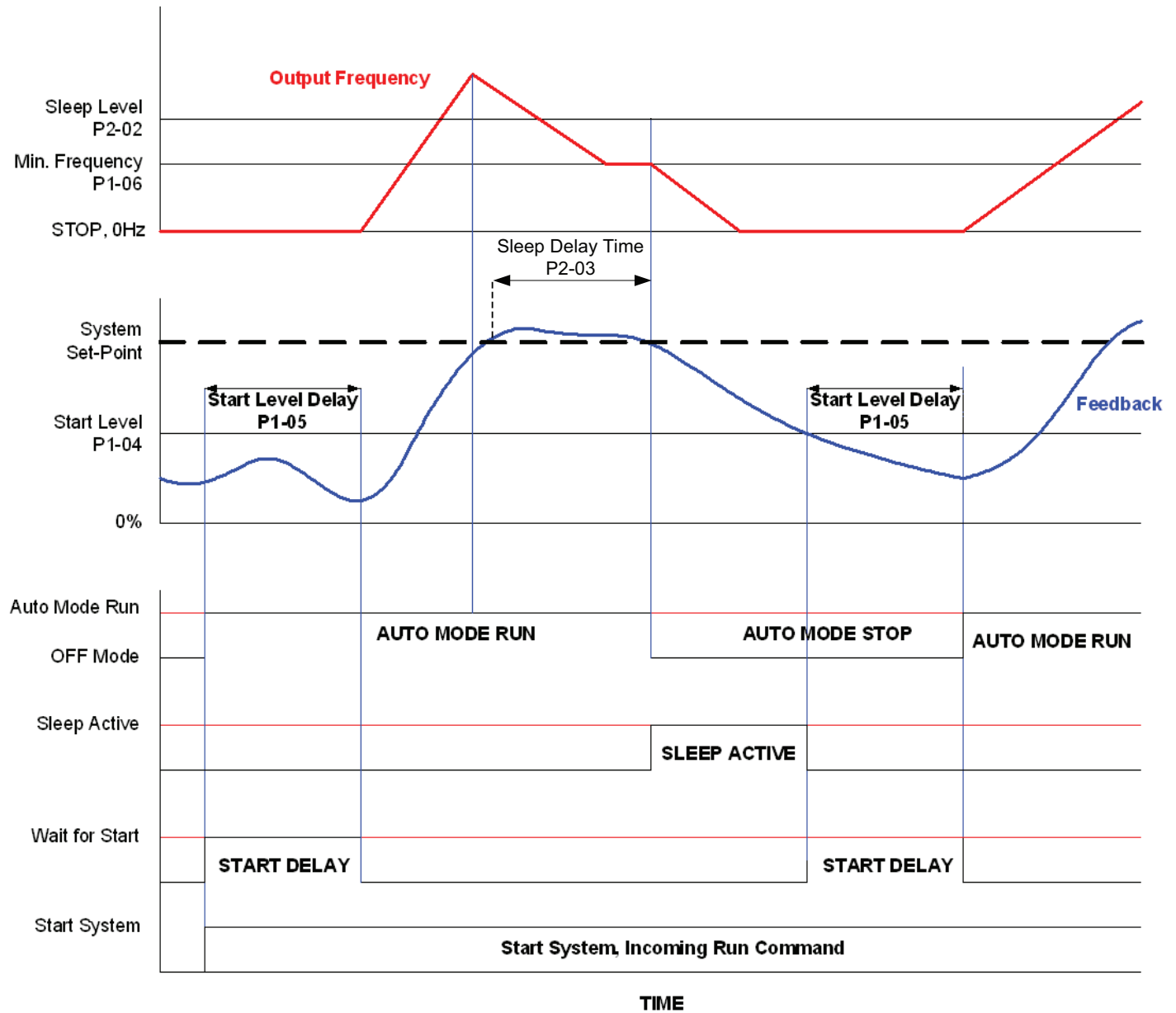

Figure 5.52 Sleep Function Based on Output Frequency

5.3 Pump Protection

■ Sleep Function Based on Output Current (P2-01 = 1)

The iQpump Controller enters sleep mode when output current falls below level programmed in P2-02 for a time specified in P2-03.

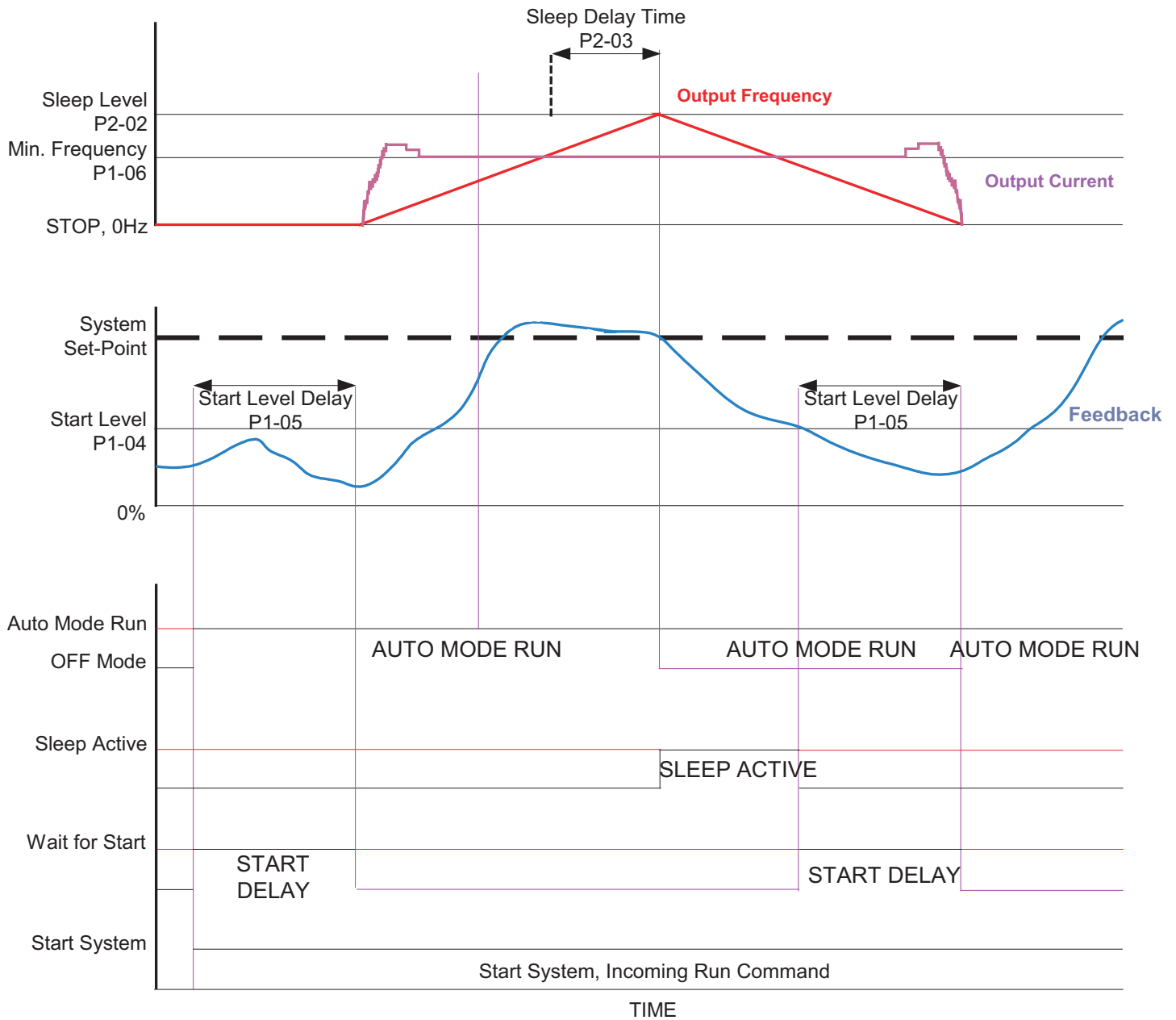

Figure 5.53 Sleep Function Based on Output Current

■ Sleep Function Based on Feedback Level (P2-01 = 2)

The iQpump Controller enters sleep mode when feedback signal rises above the level programmed in P2-02 for a time specified in P2-03. When Pi operation direction (*B5-09 Output Level Selection*) is set for Reverse Output, sleep mode will check for the feedback signal to fall below P2-02.

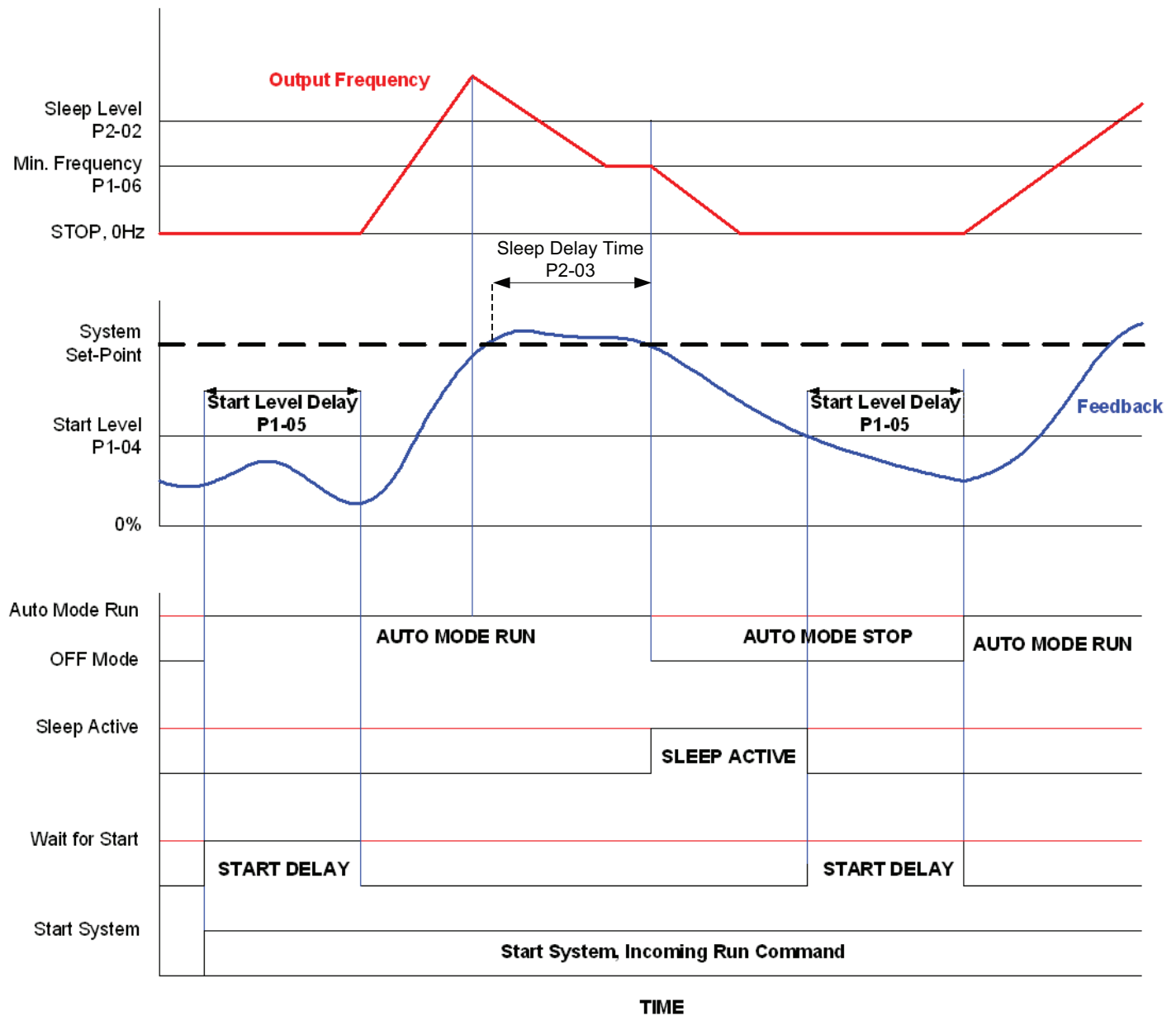

Figure 5.54 Sleep Function Based on Feedback Level

5.4 T1 Auto-Tuning

◆ T1-02 Motor Rated Power

Setting Range: 0.00 to 650.00 kW

Factory Default: Model Dependent

◆ T1-04 Motor Rated Current

Setting Range: Model Dependent

Factory Default: Model Dependent

Auto tuning is recommended to achieve optimum performance. In addition, the iQpump drive requires Line-To-Line Resistance auto-tuning before it can properly perform the Estimated Speed Search method. This method of speed search allows for bi-directional speed search. The T1 parameters are found under the Auto-Tuning menu.

To perform auto-tuning follow these steps:

1. T1-02 should be left at the default value (the last 3 digits of the iQpump drive model number).
2. In T1-04, enter the Full Load Amps (FLA) as stamped on the motor's nameplate.
3. Press the INCREASE key once to display this:

-ATUNE-	Rdy
Auto-Tuning	
0Hz/ 0.00A	
Tuning Ready ?	
Press HAND key	

4. If ready, press the HAND key once to start auto-tuning. This process will last for approximately 15 seconds. Once auto-tuning is finished, the digital operator will display this:

-ATUNE-
Tune Successful
0Hz/ 0.00A

5. To exit the Auto-Tuning menu, press the MENU key once.

Note: It is possible to get a "Data Invalid" error if the either T1-02 or T1-04 fall outside the range of what the iQpump drive will accept as reasonable levels for the programmed size of iQpump drive (o2-04).



Diagnostics & Troubleshooting

This chapter describes diagnostics and troubleshooting for the iQpump drive.

6.1 Fault Detection	136
6.2 iQpump Keypad Messages	141
6.3 Alarm Detection	143
6.4 Operator Programming Errors (OPE)	146
6.5 Auto-Tuning Faults	147
6.6 Digital Operator COPY Function Faults	148
6.7 Troubleshooting	149
6.8 Main Circuit Test Procedure	153
6.9 Drive Date Stamp Information	157

6.1 Fault Detection

When the iQpump drive detects a fault, the fault information is displayed on the digital operator, the fault contact closes, and the motor coasts to stop. (However, a fault with selectable stopping method will operate according to the stopping method selected.)

- If a fault occurs, take appropriate action according to the table by investigating the cause.
- To restart, reset the fault with any of the following procedures:
 - Turn ON the fault reset signal.
 - Set “14: Fault Reset” to a multi-function digital input (H1-01 to H1-05).
 - Press the RESET key of the digital operator.
 - Shut off the iQpump drive input power once, and then turn on again.

WARNING

The Run Command (Start Command) needs to be removed prior to resetting a fault. Resetting a fault by removing and reapplying power to the iQpump drive while the Run Command is applied, may cause the iQpump drive to start unexpectedly. Therefore, make sure all personnel are clear from the iQpump drive, motor, and machine prior to resetting the iQpump drive.

Table 6.1 Fault Displays and Processing

Digital Operator Display	Description	Cause	Corrective Action
BUS Option Com Err	Option Communication Error After initial communication was established, the connection was lost.	Connection is broken, master has stopped communicating.	Check all connections, verify all user-side software configurations.
CE Memobus Com Err	Modbus Communication Error Control data was not received correctly for two seconds.	Connection is broken, master has stopped communicating.	Check all connections, verify all user-side software configurations.
CPF00 COM- ERR(OP&INV)	Operator Communication Fault 1 Transmission between the iQpump and the digital operator cannot be established within 5 seconds after supplying power.	Digital operator cable not securely connected, digital operator defective, control board defective.	Remove the digital operator once and then reinstall it.
	External RAM of CPU is defective.	Control circuit damage.	Cycle power off and on to the iQpump. Replace the iQpump.
CPF01 COM- ERR(OP&INV)	Operator Communication Fault 2 After communication started with the digital operator, a communication fault occurred for 2 seconds or more.	Digital operator cable not securely connected, digital operator defective, control board defective.	Remove the digital operator once and then reinstall it.
			Cycle power off and on to the iQpump.
			Replace the iQpump.
CPF02 BB Circuit Err	Baseblock Circuit Fault Baseblock circuit fault at power-up.	Gate array hardware failure during power-up.	Perform a factory initialization.
			Cycle power off and on to the iQpump.
			Replace the control board.
CPF03 EEPROM Error	EEPROM Fault EEPROM fault, check sum not valid.	Noise or spike on the control circuit input terminals.	Perform a factory initialization.
			Cycle power off and on to the iQpump.
			Replace the control board.
CPF04 Internal A/D Err	CPU Internal A/D Converter Fault	Noise or spike on the control circuit input terminals.	Perform a factory initialization.
			Cycle power off and on to the iQpump.
			Replace the control board.
CPF05 External A/D Err	CPU External A/D Converter Fault	Noise or spike on the control circuit input terminals.	Perform a factory initialization.
			Cycle power off and on to the iQpump.
			Replace the control board.
CPF07 RAM-Err	ASIC Internal RAM Fault (RAM)	—	Cycle power off and on to the iQpump.
		Control circuit damage.	Replace the iQpump.

Digital Operator Display	Description	Cause	Corrective Action
CPF08 WAT-Err	Watchdog Timer Fault (WAT)	—	Cycle power off and on to the iQpump.
		Control circuit damage.	Replace the iQpump.
CPF09 CPU-Err	CPU-ASIC Mutual Diagnosis Fault (COY)	—	Cycle power off and on to the iQpump.
		Control circuit damage.	Replace the iQpump.
CPF10 ASIC-Err	ASIC Version Fault (ASIC)	Control circuit damage.	Replace the iQpump.
CPF20 Option A/D Error	Option Card Fault	Option card connector connection fault.	Remove all inputs to the option board.
		Option card A/D converter fault.	Perform a factory initialization.
			Cycle power off and on to the iQpump.
			Replace the option board.
CPF21 Option CPU Down	Self-diagnosis Fault of Communication Option Card	Noise or spike on the communication line, defective option board.	Replace the control board.
			Perform a factory initialization.
			Cycle power off and on to the iQpump.
			Replace the option board.
CPF22 Option Type Err	Communication Option Card Code Number Fault	Unrecognizable option board is connected to the control board.	Replace the control board.
			Remove any option boards.
			Cycle power off and on to the iQpump.
			Perform a factory initialization.
CPF23 Option DPRAM Err	Communication Option Card Interconnection Fault	An option board is not correctly connected to the control board or an option board that is not made for the iQpump is attached to the control board.	Replace the option board.
			Replace the control board.
			Remove power to the iQpump.
			Connect the option board once more.
			Perform a factory initialization.
EF0 Opt External Flt	Communication Option Card External Fault	An external fault condition exists.	Cycle power off and on to the iQpump.
			Replace the option board.
			Replace the control board.
EF3 Ext Fault S3	External Fault at Terminal S3	An external fault condition exists connected to a multi-function digital input.	Eliminate the cause of an external fault condition.
EF4 Ext Fault S4	External Fault at Terminal S4		
EF5 Ext Fault S5	External Fault at Terminal S5		
EF6 Ext Fault S6	External Fault at Terminal S6		
EF7 Ext Fault S7	External Fault at Terminal S7		
FBL Feedback Loss	PI Feedback Loss This fault occurs when PI Feedback Loss Detection is programmed to fault (b5-12 = 2) and the PI Feedback < PI Feedback Loss Detection Level (b5-13) for the PI Feedback Loss Detection Time (b5-14).	PI Feedback source (e.g. transducer, sensor, building automation signal) is not installed correctly or is not working.	Verify iQpump is programmed to receive the PI Feedback source signal.
			Check to ensure the PI Feedback source is installed and working properly.
GF Ground Fault	Output Ground Fault iQpump output grounding current has exceeded 50% of the iQpump rated output current.	Motor lead is shorted to ground, DCCT defective.	Remove the motor and run the iQpump without the motor.
			Check the motor for a phase-to-ground short.
			Check the output current with a clamp on meter to verify the DCCT reading.

6.1 Fault Detection

Digital Operator Display	Description	Cause	Corrective Action
LF Output Phase Loss	Output Open-phase An open-phase occurred at the iQpump output. This fault is detected when output current has exceeded 5% imbalance.	There is a broken wire in the output cable.	Check the wiring to the motor.
		There is a broken wire in the motor winding.	Check the motor for phase-to-ground short.
		The output terminals were loose.	
		The motor being used has a capacity less than 5% of the iQpump's maximum motor capacity.	Check the motor and iQpump capacity.
		Low impedance motor was used.	Add additional impedance.
Parameter E2-03 set incorrectly.	Adjust E2-03 to a lower value.		
LL3 Loss of Load Det 1	Loss of Load Detection 1 iQpump output current < L6-02 for more than the time set in L6-03.	Motor is underloaded.	Ensure the values in L6-02 and L6-03 are appropriate.
			Check application/machine status to eliminate fault.
OC Over Current	Overcurrent iQpump output current exceeded the overcurrent detection level (approximately 180% of iQpump rated output current).	Shorted iQpump output phase-to-phase, shorted motor, locked rotor, load too heavy, accel/decel time too short, contactor on the iQpump output is opened and closed, a special motor or a motor with a FLA rating larger than iQpump rated output current.	Remove the motor and run the iQpump without the motor.
			Check the motor for a phase-to-phase short.
			Check the iQpump for a phase-to-phase short at the output.
			Verify C1-01 to C1-06 are set correctly.
			Check load conditions.
OH1 Heatsink MAX Temp	Cooling Fin/Cooling Fin Fan Overheat The temperature of the iQpump cooling fin exceeded the temperature programmed in parameter L8-02, and L8-03 = 0-2.	Cooling fan(s) are not working, high ambient temperature, a heat source is too close to the iQpump.	Check for dirt build-up on the fans and cooling fins.
	iQpump Internal Cooling Fan.		Reduce the ambient temperature around the iQpump. Remove the heating unit/Replace the cooling fan.
OH3 Motor Overheat 1	Motor Overheating Alarm The iQpump stops or continues operation according to the setting of L1-03.	Overheating of motor as measured by motor thermistor.	Recheck the cycle time and the size of the load.
			Recheck the accel/decel time (C1-01 to C1-06).
			Recheck the V/F pattern (E1-01 thru E1-13).
			Recheck the motor rated current value (E2-01).
OH4 Motor Overheat 2	Motor Overheating Fault The iQpump stops operation according to the setting of L1-04.	Overheating of motor as measured by motor thermistor.	Recheck the cycle time and the size of the load.
			Recheck the accel/decel time (C1-01 to C1-06).
			Recheck the V/F pattern (E1-01 thru E1-13).
			Recheck the motor rated current value (E2-01).
OL1 Motor Overloaded	Motor Overload Designed to protect the motor. Fully adjustable from parameter E2-01.	The load is too large. The cycle time is too short at the accel/decel time.	Recheck the cycle time and the size of the load as well as the times set in C1-01 and C1-03 to C1-06.
		The voltage of the V/F pattern is high.	Review the V/F pattern parameters, E1-01 thru E1-13.
		Motor rated current setting is improper.	Check the motor rated current value in E2-01.

Digital Operator Display	Description	Cause	Corrective Action
OL2 Inv Overloaded	iQpump Overload Designed to protect the iQpump.	The load is too large. The cycle time is too short at the accel/decel time.	Recheck the cycle time and the size of the load as well as the times set in C1-01 and C1-03 to C1-06.
		The voltage of the V/F pattern is high.	Review the V/F pattern parameters, E1-01 thru E1-13.
		The size of the iQpump is small.	Change to a larger size iQpump.
OL3 Overtorque Det 1	Overtorque Detection 1 iQpump output current > L6-02 for more than the time set in L6-03.	Motor is overloaded.	Ensure the values in L6-02 and L6-03 are appropriate.
			Check application/machine status to eliminate fault.
OPR Oper Disconnect	Digital Operator Connection Fault The iQpump will stop if the digital operator is removed when the iQpump is commanded to run through the digital operator.	The digital operator is not attached or the digital operator connector is broken.	Attach the digital operator.
			Check the digital operator connector.
			Verify the setting of o2-06.
OV DC Bus Overvolt	DC Bus Overvoltage 208-240 VAC: Trip point is ≥ 400 Vdc. 480 VAC: Trip point is ≥ 800 Vdc.	High input voltage at R/L1, S/L2 and T/L3.	Check the input circuit and reduce the input power to within specifications
		The deceleration time is set too short.	Extend the time in C1-02, C1-04 or C1-06.
		Power factor correction capacitors are being used on the input to the iQpump.	Remove the power factor correction capacitors.
PF Input Pha Loss	Input Phase Loss iQpump input power supply has an open phase or has a large imbalance of input voltage.	Open phase on input of the iQpump.	Check the input voltage.
		Loose terminal screws at R/L1, S/L2 or T/L3.	Tighten the terminal screws.
		Momentary power loss occurred.	Check the input voltage.
		Input voltage fluctuation too large.	Check the input voltage.
		Parameter L8-06 value is set incorrectly.	Verify parameter L8-06 is set correctly per the kVA tables on pages C-2 and C-3. Adjust L8-06 according to your application. The higher the value the less sensitive it becomes. CAUTION: Changing this parameter from the factory default setting may cause iQpump failure and void the product warranty. (Consult the factory for application assistance).
PUF DC Bus Fuse Open	DC Bus Fuse Detects if the DC bus fuse has opened.	Shorted output transistor(s) or terminals.	Remove power from the iQpump.
			Disconnect the motor.
			Perform the checks without power in Table 6.6.
			Replace the shorted component(s).
RH DynBrk Resistor	Dynamic Braking Resistor The protection of the dynamic braking resistor based on setting of L8-01.	Overhauling load, extended dynamic braking duty cycle, defective dynamic braking resistor.	Replace the defective fuse.
			Verify dynamic braking duty cycle. Monitor DC bus voltage. Replace dynamic braking resistor.
RR DynBrk Transistr	Dynamic Braking Transistor The dynamic braking transistor failed.	Shorted dynamic braking transistor, high DC bus voltage, defective dynamic braking resistor.	Cycle power off and on to the iQpump.
			Replace defective dynamic braking transistor or resistor. Monitor DC bus voltage.
UV1 DC Bus Undervolt	DC Bus Undervoltage The DC bus voltage is \leq L2-05. 208-240 VAC: Trip point is ≤ 190 Vdc. 480 VAC: Trip point is ≤ 380 Vdc.	Low input voltage at R/L1, S/L2 and T/L3.	Check the input circuit and increase the input power to within specifications.
		The acceleration time is set too short.	Extend the time in C1-01, C1-03, or C1-05.
		Voltage fluctuation of the input power is too large.	Check the input voltage.

6.1 Fault Detection

Digital Operator Display	Description	Cause	Corrective Action
UV2 CTL PS Undervolt	Control Power Supply Undervoltage Undervoltage of the control circuit when running.	External load connected pulling down the iQpump power supplies.	Cycle power off and on to the iQpump.
			Repair or replace the Power PCB/Gate iQpump PCB.
			Remove all control wiring and test iQpump.
UV3 MC Answerback	Soft Charge Circuit Fault The pre-charge contactor opened while the iQpump was running.	Contacts on the soft charge contactor are dirty and the soft charge contactor does not function mechanically.	Cycle power off and on to the iQpump.
			Check the condition of the soft charge contactor.
			Repair or replace the Power PCB/Gate iQpump PCB.

WARNING

Some features within the PI function group cause the iQpump to shut down momentarily (e.g. Sleep Function, Snooze Function, Feedback Loss feature etc.) Upon recovery from the conditions that activate these features, the iQpump may start unexpectedly. Therefore, when enabling these features take appropriate measures to notify personnel working with this equipment that unexpected starting may occur.

6.2 iQpump Keypad Messages

◆ Pump Fault and Alarm Messages

The iQpump has a comprehensive set of dedicated pump alarms and faults that will alert the operator when the pump system has experienced any problems. A warning or fault message on the operator display indicates abnormal iQpump drive status.

■ Pump Fault Messages Generated

Table 6.2 Pump Fault Messages Generated

Digital Operator Display	Description	Cause	Corrective Action
EF1-7 Pump Fault S#	External Pump Fault	Digital input is closed.	Check incoming digital signal from external device.
FBL Feedback Loss <0032>	PI Feedback Loss This fault occurs when PI Feedback Loss Detection is programmed to fault (b5-12 = 2) and the PI Feedback < PI Feedback Loss Detection Level (b5-13) for the PI Feedback Loss Detection Time (b5-14).	PI Feedback source (e.g. transducer, sensor, building automation signal) is not installed correctly or is not working.	Verify iQpump is programmed to receive the PI Feedback source signal. Check to ensure the PI Feedback source is installed and working properly.
HFB High Feedback	High Feedback Fault Feedback signal is too high.	The feedback level has risen above P1-09 level for the time specified in P1-10. High feedback fault is active in Hand Mode, Auto Mode, Pre-charge and Thrust Mode when the Drive is running.	Feedback level lower than the high feedback level (P1-09).
LFB/LW Low FB / Water	Low Feedback Level Fault Feedback signal is too low or water low input closed.	The feedback level has dropped below P1-07 for the time specified in P1-08 or water low input is active. Low feedback fault is active in Auto Mode when the iQpump is running. Digital input is closed.	Feedback level greater than the low feedback level (P1-07). Check incoming digital signal from external device.
LOP Loss of Prime <0032>	Loss of Prime Fault Pump has lost its prime.	If the output current drops below the P1-14 Prime Loss Level for the time specified in P1-12 and the output frequency is at fmax, a "Loss of Prime (LOP)" fault occurs Possible cause: Dry Well, Air in System, No Water	Allow system to pump water again (must have resistance in pump).
NMS Set Point Not Met <0032>	Not Maintaining Set Point Fault Set Point cannot be maintained.	When the setpoint cannot be maintained for a time specified in P1-12, a "Not Maintaining Setpoint (NMS)" fault occurs. The function is disabled when the drive is not running and the PID is not active. Possible cause: Blocked Impeller, Over-Cycling, Broken Pipe	Reduce the difference between the setpoint and the feedback smaller than the Maximum Setpoint Difference (P1-11).
OPE12 <0032>	Thermostat Fault Selection Fault	Both Normally Open (H1-xx= 83) and the Normally Closed (H1-xx = 87) Thermostat Fault inputs have been programmed	Only use one of the two fault inputs.

6.2 iQpump Keypad Messages

Digital Operator Display	Description	Cause	Corrective Action
POC Pump Over Cycle	Pump Over Cycle Protection	VFD Controlled Pump exceeds number of Normal Operation to Sleep Mode Cycles. Cycle limit (P2-09) for time specified in P2-10.	Adjust sleep parameters to prevent system from cycling.
THMS Thermostat	Thermostat Fault	Digital input is closed.	Check incoming digital signal from external device.

6.3 Alarm Detection

The alarms are iQpump drive protection functions that do not operate the fault contact. The iQpump drive will automatically return to its original status once the cause of the alarm has been removed.

During an alarm condition, the digital operator display flashes and an alarm output is generated at the multi-function outputs (H2-01 to H2-02) if programmed.

When an alarm occurs, take appropriate corrective action according to the table below.

Table 6.3 Alarm Displays and Processing

Digital Operator Display	Description	Cause	Corrective Action
BUS Option Com Err	Option Communication Error After initial communication was established, the connection was lost.	Connection is broken, master has stopped communicating.	Check all connections, verify all user side software configurations.
CALL SI-F/G ComCall	Serial communication transmission error. Communication has not yet been established.	Connection not made properly, user software not configured to the proper baud rate or configuration.	Check all connections, verify all user side software configurations.
EF External Fault	External fault at terminals S1 and S2 Both the forward and the reverse run commands are input simultaneously for 500mS or more. This alarm stops the motor.	An external forward and reverse command are input simultaneously.	Check external sequence logic.
EF0 Opt External Flt (Flashing)	Communication Option Card External Fault	An external fault condition exists.	Check for an external condition. Verify the parameters. Verify communication signal.
EF3 Ext Fault S3 (Flashing)	External Fault at Terminal S3	An external fault condition exists connected to a multi-function digital input.	Eliminate the cause of an external fault condition.
EF4 Ext Fault S4 (Flashing)	External Fault at Terminal S4		
EF5 Ext Fault S5 (Flashing)	External Fault at Terminal S5		
EF6 Ext Fault S6 (Flashing)	External Fault at Terminal S6		
EF7 Ext Fault S7 (Flashing)	External Fault at Terminal S7		
DNE iQpump not Enable (Flashing)	iQpump enable command missing. The iQpump does not have the enable command when the run command is applied.	The Run command has been applied prior to the enable signal.	Apply the enable command before applying the run command.
FAN Cooling Fan Error	Failure of the iQpump internal cooling fan when L8-32 = 0.	iQpump cooling fan has stopped.	Replace the cooling fan.
FBL Feedback Loss <0032>	PI Feedback Loss This fault occurs when PI Feedback Loss Detection is programmed to fault (b5-12 = 2) and the PI Feedback < PI Feedback Loss Detection Level (b5-13) for the PI Feedback Loss Detection Time (b5-14).	PI feedback source (e.g. transducer, sensor, building automation signal) is not installed correctly or is not working.	Verify iQpump is programmed to receive the PI feedback source signal. Check to ensure the PI feedback source is installed and working properly. Check the motor for a phase-to-phase short. Check the iQpump for a phase-to-phase short at the output. Verify C1-01 to C1-06 are set correctly. Check load conditions.

6.3 Alarm Detection

Digital Operator Display	Description	Cause	Corrective Action
LL3 Loss of Load Det 1 (Flashing)	Loss of Load Detection 1 iQpump output current < L6-02 for more than the time set in L6-03.	Motor is underloaded.	Ensure the values in L6-02 and L6-03 are appropriate.
			Check application/machine status to eliminate fault.
OH Heatsnk Overtemp (Flashing)	Cooling Fin/Cooling Fin Fan Overheat The temperature of the iQpump cooling fin exceeded the temperature programmed in parameter L8-02.	Cooling fan(s) are not working, high ambient temperature, a heating unit in close proximity to iQpump is present.	Check for dirt build-up on the fans and cooling fins.
	iQpump Internal Cooling Fan.		Reduce the ambient temperature around the iQpump. Remove the heating unit.
OH2 Over Heat 2 (Flashing)	iQpump overheat pre-alarm signal is input from a multi-function digital input terminal.	An external overheat condition exists connected to one of the multi-function input terminals S3, S4, S5, S6 or S7.	Check for an external condition. Verify the program parameters H1-01 thru H1-05.
OH3 Motor Overheat 1 (Flashing)	Motor Overheating Alarm The iQpump stops or continues operation according to the setting of L1-03.	Overheating of motor.	Recheck the cycle time and the size of the load.
			Recheck the accel/decel time (C1-01 to C1-06).
			Recheck the V/F pattern (E1-01 thru E1-13).
			Recheck the motor rated current value (E2-01).
			Check the digital operator connector.
			Verify the setting of o2-06.
OV DC Bus Overvolt (Flashing)	DC Bus Overvoltage 208-240 VAC: Trip point is ≥ 400 Vdc. 480 VAC: Trip point is ≥ 800 Vdc.	High input voltage at R/L1, S/L2 and T/L3.	Check the input circuit and reduce the input power to within specifications.
		The deceleration time is set too short.	Extend the time in C1-02, C1-04, or C1-06.
		Power factor correction capacitors are being used on the input to the iQpump.	Remove the power factor correction capacitors.
PRHT Motor Preheating	Motor Preheating Motor is preheating.	Motor Preheat 2 input is closed.	—
UV DC Bus Undervolt (Flashing)	DC Bus Undervoltage The DC bus voltage is \leq L2-05. 208-240 VAC: Trip point is ≤ 190 Vdc. 480 VAC: Trip point is ≤ 380 Vdc.	Low input voltage at R/L1, S/L2 and T/L3.	Check the input circuit and increase the input power to within specifications.
		The acceleration time is set too short.	Extend the time in C1-01, C1-03, or C1-05.
		Voltage fluctuation of the input power is too large.	Check the input voltage.
UV2 CTL PS Undervolt	Control Power Supply Undervoltage of the control circuit when running.	External load connected pulling down the iQpump power supplies.	Cycle power off and on to the iQpump. Repair or replace the Power PCB/Gate iQpump PCB.
UV3 MC Answerback	Soft Charge Circuit Fault The pre-charge contactor opened while the iQpump was running.	Contacts on the soft charge contactor are dirty and the soft charge contactor does not function mechanically.	Cycle power off and on to the iQpump.
			Check the condition of the soft charge contactor.

◆ Pump Alarm Messages Generated

Digital Operator Display	Description	Cause	Corrective Action
Low Feedback Low FB Sensed	Low Feedback Level Alarm Feedback signal is too low.	The feedback level has dropped below the low feedback level (P1-07). Low feedback fault is active in Auto Mode when the iQpump drive is running.	Feedback level greater than the low feedback level (P1-07).
High Feedback High FB Sensed	High Feedback Alarm Feedback signal is too high.	The feedback level has risen above P1-09 level. High feedback alarm is active in Hand Mode, Auto Mode, Pre-charge and Thrust Mode when the iQpump drive is running.	Feedback level lower than the high feedback level (P1-09).
Start Delay Timer Active	Start Delay Start delay timer is active.	Displays when the iQpump drive is about to start. The feedback level is fallen below the start level (P1-04) and the start delay timer is active. Once the start level delay time (P1-05) expires, the iQpump drive will start. When PI output level selection (b5-09) is programmed for reverse, the alarm is displayed when the feedback level falls rises above start level (P1-04).	Wait for the start level delay time to expire. Program a different start level delay time.
Sleep Active Wait for Start	During Sleep / Wait for Start Sleep mode waiting for appropriate levels to start.	Displays when the iQpump drive is in the “sleep” mode or when the iQpump drive is waiting for feedback level to drop below start level (P1-04). When PI output level selection (b5-09) is programmed for reverse, the alarm is displayed when feedback level falls below start level (P1-04).	Wait for the sleep mode time to deactivate. Program a different start level or disable sleep mode.
Pre-Chg Mode Pre-Chg Active	During Pre-Charge The pre-charge mode is active.	Displays when “Pre-charge” mode is active.	Wait for pre-charge mode to deactivate. Disable pre-charge mode.
Pump Cycling Pump Over Cycle	Pump Over Cycle The number of cycles is exceeded.	VFD Controlled Pump exceeds number of Normal Operation to Sleep Mode Cycles. Cycle limit (P2-09) for time specified in P2-10.	Adjust sleep parameters group P2 to prevent system from cycling.
Thrust Mode Thrust Active	Thrust Bearing The thrust bearing mode is active.	Displays when “Thrust Bearing” mode is active.	Wait for thrust bearing mode to deactivate. Disable thrust bearing mode.

6.4 Operator Programming Errors (OPE)

An Operator Programming Error (OPE) occurs when an inapplicable parameter is set or an individual parameter setting is inappropriate. The iQpump drive does not operate until the parameter is set correctly. (Alarm output and fault contact do not operate.)

If an OPE occurs, change the appropriate parameter by checking the cause shown in [Table 6.4](#).

Table 6.4 OPE Error and Fault Displays

Digital Operator Display	Description	Cause	Corrective Action
OPE01 kVA Selection	Drive kVA setting error.	The control board was replaced and the kVA parameter is set incorrectly.	Enter the correct kVA setting (o2-04) by referring to the iQpump drive model number in Appendix B .
OPE02 Limit	Parameter data out of range.	Parameter set above the allowable range.	Verify the program settings.
OPE03 Terminal	Multi-function input selection fault.	Duplicate functions are selected. Speed search from maximum frequency and set frequency are set simultaneously. MOP Increase (H1-0X = 10) and MOP Decrease (H1-0X = 11) are not set simultaneously.	Verify program settings. (H1-01~H1-05)
OPE05 Sequence Select	Run command is selected through serial communication at 2CN but option board is not installed.	Serial communication option board is not installed, option board is installed incorrectly. The run command selection parameter. b1-02 is set to 3 and option board is not installed.	Verify that the board is installed. Remove power to the iQpump drive and connect the option board once more.
OPE10 V/f Ptn Setting	V/f data setting fault	V/f parameter settings are not set correctly.	Check parameters (E1-04 ~ E1-11). A minimum frequency/voltage value may be set higher than the maximum frequency/voltage.
OPE11 CarrFrq/On-Delay	Carrier frequency data setting fault. Carrier frequency proportional gain C6-05 > 6 and C6-04 > C6-03. Upper/lower limit error of C6-03 to 5.0kHz.	Parameter setting incorrect.	Check the program settings and correct the errors.
ERR EEPROM R/W Err	It does not match at EEPROM write.	<ul style="list-style-type: none"> Power supply is turned OFF. Parameter is reset repeatedly. 	<ul style="list-style-type: none"> Cycle power off and on to iQpump. Do a factory initialization (A1-03).

6.5 Auto-Tuning Faults

Auto-tuning faults are shown below. When the following faults are detected, the fault is displayed on the digital operator and the motor coasts to a stop during operation. The fault contact is not activated.

Table 6.5 Auto-Tuning Displays and Processing

Digital Operator Display	Probable Cause	Corrective Action
Er - 01 Fault	<ul style="list-style-type: none"> • There is an error in the data input for autotuning. • There is an error in the relationship between the motor output and the motor rated current. 	<ul style="list-style-type: none"> • Check input data. • Check iQpump and motor capacity. • Check motor rated current.
Er - 02 Minor Fault	A minor fault is detected during auto-tuning.	<ul style="list-style-type: none"> • Check input data. • Check wirings and around the machine. • Check the load.
Er - 03 STOP key	The STOP key is pressed during auto-tuning, and the auto-tuning is interrupted.	—
Er - 04 Resistance	<p>Auto-tuning is not completed within the specified time.</p> <p>The auto-tuning result became other than the parameter set range.</p>	<ul style="list-style-type: none"> • Check input data. • Check motor wiring. • If a motor and a machine are connected, disconnect the motor from the machine.
Er - 12 I-det. Circuit	<ul style="list-style-type: none"> • Current flow exceeded the motor rated current. • Current detection value symbol was reversed. • Any of U/T1, V/T2, and W/T3 has open-phase. 	<ul style="list-style-type: none"> • Check current detection circuit, wiring and mounting procedure.
Er - 13 Leakage Inductance Fault	<p>Auto-tuning did not finish within the set time.</p> <p>Tuning result was outside the acceptable parameter setting range.</p>	<ul style="list-style-type: none"> • Check motor wiring.
End - 3 Data Invalid	Rated current set value is set too high.	<ul style="list-style-type: none"> • Check input data (especially, motor output current and motor rated current value).

6.6 Digital Operator COPY Function Faults

These faults can occur occurred during the operator COPY function. Fault content is displayed on the operator. An error during the COPY function does not activate the fault contact output or alarm output.

Table 6.6 Digital Operator COPY Function Faults

Function	Digital Operator Display	Probable Causes	Corrective Action
READ Function	PRE READ IMPOSSIBLE	o3-01 was set to 1 to write a parameter when the digital operator was write-protected (o3-02 = 0).	Set o3-02 to 1 to enable writing parameters with the digital operator.
	IFE READ DATA ERROR	The read data length does not agree. The write data is incorrect.	<ul style="list-style-type: none"> Repeat the Read. Check the digital operator cable. Replace digital operator.
	RDE DATA ERROR	An attempted write of a parameter to EEPROM on the digital operator failed.	<ul style="list-style-type: none"> A low Inverter voltage has been detected. Repeat the read. Replace digital operator.
COPY Function	CPE ID UNMATCHED	The iQpump product code or software number is different.	Use COPY function for the same product code and software number.
	VAE INV. KVA UNMATCH	The capacity of the iQpump being copied and the capacity in the digital operator are different.	Use COPY function for the same iQpump drive capacity.
	CRE CONTROL UNMATCHED	The control method of the iQpump being copied and the control method in the digital operator are different.	Use the COPY function for the same control method.
	CYE COPY ERROR	The parameter written to the iQpump was compared with the parameter in the digital operator and they were different.	COPY retest.
	CSE SUM CHECK ERROR	The checksum in the iQpump parameter area was compared with the checksum in the digital operator parameter area and they were different.	Retry the copy.
Verify Function	VYE VERIFY ERROR	The set value of the digital operator and the iQpump do not match.	Retry Verify function. After COPY is retested, Verify is retested.

6.7 Troubleshooting

Due to parameter setting errors, faulty wiring, etc., the iQpump drive and motor may not operate as expected when the system is started up. If this occurs, use this section as a reference and apply the appropriate measures.

If a fault is displayed on the digital operator, refer to [Table 6.1](#).

◆ If Parameter Cannot Be Set

Use the following information if an iQpump drive parameter cannot be set.

■ The display does not change when the INCREASE and DECREASE keys are pressed.

The following causes are possible.

The iQpump drive is operating (drive mode).

There are some parameters that cannot be set during operation. Remove the run command and then set the parameters.

Parameter write enable is input.

This occurs when “parameter write enable” (set value: 1B) is set for a multi-function digital input terminal (H1-01 to H1-05). If the parameter write enable input is OFF, the parameters cannot be changed. Turn it ON and then set the parameters.

Passwords do not match. (Only when a password is set.)

If the parameter A1-04 (Password) and A1-05 (Password Setting) numbers are different, the parameters for the initialize mode cannot be changed. Enter the correct password in A1-04.

If you cannot remember the password, display A1-05 (Password Setting) by pressing the Shift/Reset Key and the MENU Key simultaneously while in the A1-04 display. Reset the password and input the reset password in parameter A1-04.

■ OPE01 through OPE11 is displayed.

The set value for the parameter is wrong. Refer to [section 6.4 Operator Programming Errors \(OPE\)](#) in this chapter and correct the setting.

■ CPF00 or CPF01 is displayed.

This is a Digital Operator communications error. The connection between the Digital Operator and the iQpump drive may be faulty. Remove the Digital Operator and then re-install it.

◆ If the Motor Does Not Operate

Use the following information if the motor does not operate.

- **Ensure the digital operator is securely connected to the iQpump drive.**
- **The motor does not operate when the HAND key on the Digital Operator is pressed.**

The following causes are possible:

The Speed Command (Frequency Reference) is too low.

If the Speed Command (frequency reference) is set below the frequency set in E1-09 (Minimum Output Frequency), the iQpump drive will not operate.

Raise the Speed Command to at least the minimum output frequency.

- **The motor does not operate when an external run command is input.**

The following causes are possible.

The iQpump drive is not in drive mode.

If the iQpump drive is not in drive mode, it will remain in ready status and will not start. Press the MENU key once and press the DATA/ENTER key. The iQpump drive is now in drive mode.

The Speed Command is too low.

If the Speed Command is set below the frequency set in E1-09 (Minimum Output Frequency), the iQpump drive will not operate. Raise the Speed Command to at least the minimum output frequency.

- **The motor stops during acceleration or when a load is connected.**

The load may be too high. The iQpump drive has a stall prevention function and an automatic torque boost function, but the motor responsiveness limit may be exceeded if acceleration is too rapid or if the load is too great. Lengthen the acceleration time (C1-01, C1-03, or C1-05) or reduce the load. Also consider increasing the motor size.

◆ The Direction of the Motor Rotation is Reversed

If the motor rotates in the wrong direction, the motor output wiring is incorrect. When the iQpump drive U/T1, V/T2, and W/T3 terminals are properly connected to the motor, the motor operates in a forward direction when a forward run command is received. The forward direction depends on the manufacturer and the motor type, so be sure to check the specifications.

The direction of rotation can be reversed by switching any two wires among U/T1, V/T2, and W/T3.

◆ If the Motor Does Not Put Out Torque or If Acceleration is Slow

Use the following information if the motor does not output torque or if acceleration is too slow.

- **The stall prevention level during acceleration is too low.**

If the value set for L3-02 (Stall Prevention Acceleration Level) is too low, the acceleration time will be too long. Check to be sure that the set value is suitable.

- **The stall prevention level during running is too low.**

If the value set for L3-06 (Stall Prevention Level during Running) is too low, the motor speed and torque will be limited. Check to be sure that the set value is suitable.

◆ If the Motor Operates at a Higher Speed than the Speed Command

Use the following information if the motor operates at a higher speed than the Speed Command.

■ A signal is being input to the Speed Command (current) terminal A2.

If a preset frequency reference is selected, the preset reference takes priority over the normal reference.

If the PI mode of operation is enabled, the iQpump drive output frequency will change to regulate the process variable to the desired setpoint. Then, the iQpump drive speed may go to maximum.

◆ If the Motor Overheats

Take the following steps if the motor overheats.

■ The load is too high.

If the motor load is too high and the motor is used when the effective torque exceeds the motor's rated torque, the motor will overheat. Reduce the load amount by either reducing the load or increasing the acceleration/deceleration times. Also consider increasing the motor size.

■ The ambient temperature is too high.

The motor rating is determined by a particular ambient operating temperature range. The motor will overheat if it is run continuously at the rated torque in an environment where the maximum ambient operating temperature rating is exceeded. Lower the motor's ambient temperature to within its acceptable range.

■ The withstand voltage between the motor phases is insufficient.

When the motor is connected to the iQpump drive output, voltage surges are generated by standing waves that can occur with certain combinations of iQpump drive carrier frequency and motor cable length. Normally the maximum surge voltage is three times the iQpump drive's input power supply voltage (i.e., 1200 VAC for a 480 VAC). Be sure to use a motor with a withstand voltage between the motor phases that is greater than the maximum surge voltage. In particular, when using a 480 VAC iQpump drive, use an inverter-duty (NEMA MG1, Parts 30 & 31) motor. Motor protection filter can also be an effective measure.

◆ If Peripheral Devices Like DDCs or Others are Influenced by Starting or Running iQpump Drive

If noise is generated by iQpump drive switching, implement the following countermeasures:

1. Change the iQpump drive's carrier frequency selection (C6-02) to lower the carrier frequency. This will help to reduce the amount of internal switching.
2. Install an Input Noise Filter at the iQpump drive's input power terminals.
3. Use metal conduit. Electric waves can be shielded by metal, so encase the iQpump drive and power wires in metal.
4. Ground the iQpump drive and motor.
5. Separate main circuit wiring from control wiring.

◆ If a "Stand-alone" Ground Fault Interrupter Operates When the iQpump Drive is Run

The iQpump drive performs internal switching, so there is a certain amount of leakage current. This may cause an external ground fault interrupter to operate and cut off the power supply. Whenever possible, use a ground fault interrupter with a high leakage detection level (i.e., a sensitivity current of 200 mA or greater per Unit, with an operating time of 0.1 s or more), or one that incorporates high frequency countermeasures (i.e., one designed for use with drives). It will also help to change the iQpump drive's carrier frequency selection (C6-02) to lower the carrier frequency. In addition, remember that the leakage current increases as the cable is lengthened.

◆ If There is Mechanical Vibration

Use the following information when there is mechanical vibration.

■ The application is making unusual sounds.

The following causes are possible.

There may be resonance between the mechanical system's natural frequency and the carrier frequency.

This is characterized by the motor running with no noise generation, but the machinery vibrates with a high-pitched whine. To prevent this type of resonance, adjust the carrier frequency with parameters C6-02 to C6-05.

There may be resonance between an applications characteristic frequency and the output frequency of the iQpump drive.

To prevent this from occurring, use the jump frequency functions in parameters d3-01 to d3-04, or have the driven motor and load balanced to reduce vibration.

■ Oscillation and hunting are occurring with V/f control.

The gain adjustment may be insufficient. Reset the gain to a more effective level by raising the value of C4-02 (Torque Compensation Primary Delay Time Parameter) and then lowering the setting of n1-02 (Hunting Prevention Gain).

■ Oscillation and hunting are occurring with PI control.

If there is oscillation or hunting during PI control, check the oscillation cycle and individually adjust P and I parameters.

- Disable integral (I) control
- Reduce the proportional gain (P) until hunting stops
- Reintroduce the integral function, starting with long integral time values, to eliminate the P offset

◆ If the Motor Rotates Even When iQpump Drive Output is Stopped

If the motor rotates even when the iQpump drive is stopped, the DC injection braking may be insufficient. If the motor continues operating at low speed, without completely stopping after a stop has been executed, it means that the DC injection braking is not decelerating the motor enough. Adjust the DC injection braking as follows:

- Increase the parameter b2-04 (DC Injection Braking (initial excitation) Time at Stop) setting.
- Increase the parameter b2-02 (DC Injection Braking Current) setting.

◆ If Zero Volts is Detected When a Motor is Started, or Stalls

Generation of 0 V (main circuit voltage) and stalling can occur if a motor is turning when it is started and the DC injection braking is insufficient.

This can be prevented by slowing motor rotation by DC injection braking before starting. Increase parameter b2-03 (DC injection braking time at start) setting.

◆ If the Accepted Speed Command Does Not Rise to the User Speed Command Input

■ The Speed Command is within the jump frequency range.

When the jump frequency function is used, the output frequency cannot be set within the jump frequency range. Check to be sure that the Jump Frequency (parameters d3-01 to d3-03) and Jump Frequency Width (parameter d3-04) settings are suitable.

■ The frequency reference upper limit has been reached.

The output frequency upper limit is determined by the following formula:

- Freq Ref Upper Limit = Maximum Output Frequency (E1-04) × Frequency Reference Upper Limit (d2-01) / 100
- Check to be sure that the parameter E1-04 and d2-01 settings are suitable.

6.8 Main Circuit Test Procedure

WARNING

Prior to removing any protective cover or wiring any part of the iQpump drive, remove all power sources, including main input power and control circuit power. Wait a minimum of 5 minutes after power removal, before removing any cover. The charge lamp located within the iQpump drive should be off prior to working inside. Even if the charge lamp is off, one must measure the AC input, output, and DC Bus potential to insure safe levels prior to resuming work. Failure to adhere to this warning may result in personal injury or death.

Before attempting any troubleshooting checks, make sure that the three-phase power is disconnected and locked out. With power removed from the unit, the DC bus capacitors will stay charged for several minutes. The Charge LED in the iQpump drive will glow red until the DC bus voltage is below 10 Vdc. To ensure that the DC bus is completely discharged, measure between the positive and negative bus with a DC voltmeter set to the highest scale.

Table 6.7 Main Circuit Test Procedures

Check	Procedure
Measure DC Bus Voltage	<ol style="list-style-type: none"> 1. Set the digital multi-meter to its highest VDC scale. 2. Measure between \oplus 1 and (-) for the following check: Place the positive (red) meter lead on \oplus 1. Place the negative (black) meter lead on (-). 3. If the measured voltage is < 10 Vdc, it is safe to work inside the Drive. If not, wait until the DC Bus has completely discharged.
Input Diodes (D1-D12 or Q1)	<p>The input diodes rectify or transform the three-phase input AC voltage into a DC voltage.</p> <ol style="list-style-type: none"> 1. Set a digital multi-meter to the Diode Check setting. 2. Place the positive (red) meter lead on terminal R/L1. Place the negative (black) meter lead on terminal \oplus 1. Expected reading is about 0.5 Volts. 3. Place the positive (red) meter lead on terminal S/L2. Place the negative (black) meter lead on terminal \oplus 1. Expected reading is about 0.5 Volts. 4. Place the positive (red) meter lead on terminal T/L3. Place the negative (black) meter lead on terminal \oplus 1. Expected reading is about 0.5 Volts. 5. Place the positive (red) meter lead on terminal R/L1. Place the negative (black) meter lead on terminal (-). Expected reading is OL displayed. 6. Place the positive (red) meter lead on terminal S/L2. Place the negative (black) meter lead on terminal (-). Expected reading is OL displayed. 7. Place the positive (red) meter lead on terminal T/L3. Place the negative (black) meter lead on terminal (-). Expected reading is OL displayed. 8. Place the positive (red) meter lead on terminal (-). Place the negative (black) meter lead on terminal R/L1. Expected reading is about 0.5 Volts. 9. Place the positive (red) meter lead on terminal (-). Place the negative (black) meter lead on terminal S/L2. Expected reading is about 0.5 Volts. 10. Place the positive (red) meter lead on terminal (-). Place the negative (black) meter lead on terminal T/L3. Expected reading is about 0.5 Volts. 11. Place the positive (red) meter lead on terminal \oplus 11. Place the negative (black) meter lead on terminal R/L1. Expected reading is OL displayed. 12. Place the positive (red) meter lead on terminal \oplus 1. Place the negative (black) meter lead on terminal S/L2. Expected reading is OL displayed. 13. Place the positive (red) meter lead on terminal \oplus 1. Place the negative (black) meter lead on terminal T/L3. Expected reading is OL displayed.

6.8 Main Circuit Test Procedure

Check	Procedure
Soft Charge Resistor Check (R1, R2, 6PCB)	The soft charge resistor works in conjunction with the soft charge contactor to slowly charge the DC bus capacitors to minimize the inrush current when power is applied to the Drive. <ol style="list-style-type: none"> 1. Conduct a visual inspection. Check for physical damage. 2. Set a digital multi-meter to the R x 1 scale. 3. If the resistor is damaged, the measured value will be infinite ohms.
Soft Charge Contactor (K1)	The purpose of the soft charge contactor is to bypass the soft charge resistor after the DC bus voltage has reached its normal operating level. <ol style="list-style-type: none"> 1. Conduct a visual inspection. Check for physical damage. 2. Set a digital multi-meter to the R x 1 scale. 3. On Drives with a board-mounted contactor, verify that each contact resistance measures infinite ohms. 4. On Drives without a board-mounted contactor, press the plunger in, and verify that each contact measures zero ohms. 5. On Drives without a board-mounted contactor, release the plunger, and verify that the resistance is the ohmic value of the soft charge resistor. 6. On Drives with a board-mounted contactor, verify that the contactor coil measures about 300 ohms. The coil can be tested by applying the appropriate voltage to verify the contacts change states. 7. On Drives without a board-mounted contactor, verify that the 230 VAC contactor coil measures about 175 ohms. The coil can be tested by applying the appropriate voltage to verify the contacts change states. 8. On Drives without a board-mounted contactor, verify that the 24 Vdc auxiliary coil measures about 2.2M ohms. The coil can be tested by applying the appropriate voltage to verify the contacts change states.
DC Bus Fuse (F1)	The DC bus fuse is located in the negative portion of the DC Bus. The DC bus fuse is used to protect the main circuit components if the output transistors short. If the DC bus fuse is open, at least one of the output transistors has failed. When a transistor fails, there is a short between the positive and negative portions of the DC Bus. The DC bus fuse does not protect the transistors, but protects the rest of the main circuit from the high current present during a short. <i>Never replace the DC bus fuse without first checking all of the output transistors.</i> <ol style="list-style-type: none"> 1. Set a digital multi-meter to the R x 1 scale. 2. Place one lead of the multi-meter on one side of the fuse and place the other lead of the multi-meter on the other side of the fuse. 3. If the fuse is good, the measured value will be zero ohms. 4. If the fuse is bad, the measured value will be infinite ohms.

Check	Procedure
<p>Output Transistors (Q1-Q12)</p>	<p>The output transistors are used to switch the DC bus voltage to allow current to flow to the motor.</p> <ol style="list-style-type: none"> 1. Set a digital multi-meter to the Diode Check setting. 2. Place the positive (red) meter lead on terminal U/T1. Place the negative (black) meter lead on terminal ⊕ 1. Expected reading is about 0.5 Volts. 3. Place the positive (red) meter lead on terminal V/T2. Place the negative (black) meter lead on terminal ⊕ 1. Expected reading is about 0.5 Volts. 4. Place the positive (red) meter lead on terminal W/T3. Place the negative (black) meter lead on terminal ⊕ 1. Expected reading is about 0.5 Volts. 5. Place the positive (red) meter lead on terminal U/T1. Place the negative (black) meter lead on terminal (-). Expected reading is OL displayed. 6. Place the positive (red) meter lead on terminal V/T2. Place the negative (black) meter lead on terminal (-). Expected reading is OL displayed. 7. Place the positive (red) meter lead on terminal W/T3. Place the negative (black) meter lead on terminal (-). Expected reading is OL displayed. 8. Place the positive (red) meter lead on terminal (-). Place the negative (black) meter lead on terminal U/T1. Expected reading is about 0.5 Volts. 9. Place the positive (red) meter lead on terminal (-). Place the negative (black) meter lead on terminal V/T2. Expected reading is about 0.5 Volts. 10. Place the positive (red) meter lead on terminal (-). Place the negative (black) meter lead on terminal W/T3. Expected reading is about 0.5 Volts. 11. Place the positive (red) meter lead on terminal ⊕ 1. Place the negative (black) meter lead on terminal U/T1. Expected reading is OL displayed. 12. Place the positive (red) meter lead on terminal ⊕ 1. Place the negative (black) meter lead on terminal V/T2. Expected reading is OL displayed. 13. Place the positive (red) meter lead on terminal ⊕ 1. Place the negative (black) meter lead on terminal W/T3. Expected reading is OL displayed.
<p>Control Power Fuse</p>	<p>All Drives have a Control Power Fuse. The fuse is located on either the Power PCB (3PCB) or the Gate Drive PCB (3PCB). The Control Power Fuse protects the primary switching mode power supply.</p> <ol style="list-style-type: none"> 1. Set a digital multi-meter to the R x 1 scale. 2. Place one lead of the multi-meter on one side of the fuse and place the other lead of the multi-meter on the other side of the fuse. 3. If the fuse is good, the measured value will be zero ohms. If the fuse is bad, the measured value will be infinite ohms.
<p>24 Vdc Cooling Fans (Heat Sink & Internal)</p>	<p>The Heat Sink & Internal Cooling Fans cool the heat sink as well as the output transistor modules of the Drive.</p> <ol style="list-style-type: none"> 1. Conduct a visual inspection to ensure the fan turns freely. 2. If there is no physical evidence that the fan is bad, the fan motor can be checked with a digital multi-meter. 3. Set the digital multi-meter to the R x 1 scale. 4. Measure across the fan motor terminals. If zero ohms are measured, conclude that the fan motor is shorted. If infinite ohms are measured, conclude that the fan motor is burned open. 5. If the fan is not working, then disconnect the fan and apply 24 Vdc to the fan to test the motor.
<p>230/240 VAC Cooling Fans (Heat Sink)</p>	<p>The Heat Sink Cooling Fans cool the heat sink to remove heat from the Drive.</p> <ol style="list-style-type: none"> 1. Conduct a visual inspection to ensure the fan turns freely. 2. If there is no physical evidence that the fan is bad, the motor can be checked with a digital multi-meter. 3. Set a digital multi-meter to the R x 1 scale. 4. Measure across the fan motor terminals. If the fan motor is good, the measured value should be about 500 ohms. If zero ohms are measured, conclude that the fan motor is shorted. If infinite ohms are measured, conclude that the fan motor is burned open. 5. If the fan is not working, then disconnect the fan and apply 230/240 VAC to the fan to test the motor.

6.8 Main Circuit Test Procedure

Check	Procedure
Cooling Fan Fuse	<p>Large Drive units contain a Cooling Fan Fuse. It is located on either the Gate Drive Board (3PCB) or the Tap Change Board (8PCB). If the Cooling Fan Fuse is open, then the 230/240 VAC cooling fans may be defective.</p> <ol style="list-style-type: none">1. Set a digital multi-meter to the R x 1 scale.2. Place one lead of the multi-meter on one side of the fuse and place the other lead of the multi-meter on the other side of the fuse.3. If the fuse is good, the measured value will be zero ohms. If the fuse is bad, the measured value will be infinite ohms.

6.9 Drive Date Stamp Information

This information is used to determine when a iQpump drive was built to see if it is within its warranty period. The date stamp is located on the lower right side of the iQpump drive.

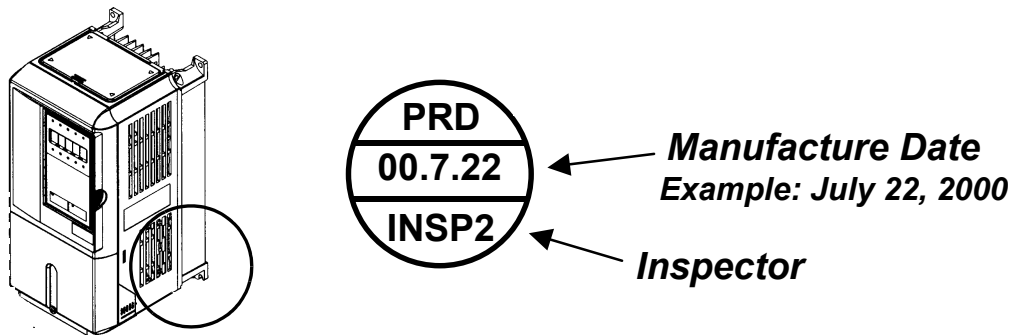

Figure 6.1 Date Stamp Location

6.9 Drive Date Stamp Information

THIS PAGE INTENTIONALLY LEFT BLANK.



Maintenance

This chapter describes basic maintenance and inspection of the iQpump drive. Please refer to these instructions to ensure that the iQpump drive receives the proper maintenance to maintain overall performance.

7.1 Periodic Inspection	160
7.2 Preventive Maintenance	161
7.3 Heatsink Cooling Fan Replacement	162
7.4 Removing and Mounting the Terminal Card	164

7.1 Periodic Inspection

Check the following items during periodic maintenance.

- The motor should not be vibrating or making unusual noises.
- There should be no abnormal heat generation from the iQpump drive or motor.
- The ambient temperature should be within the iQpump drive specification of -10°C to 40°C (14°F to 104°F).
- The output current value shown in parameter U1-03 should not be higher than the motor rated current for an extended period of time.
- The cooling fan in the iQpump drive should be operating normally.

Always turn OFF the input power before beginning inspection. Confirm that the digital operator indicators on the front cover have all turned OFF, and then wait an additional five minutes before beginning the inspection. Be sure not to touch terminals immediately after the power has been turned off. Doing so can result in electric shock. *Refer to Warnings and Cautions on page 7.*

WARNING

Prior to removing any protective cover or wiring any part of the iQpump drive, remove all power sources, including main input power and control circuit power. Wait a minimum of 5 minutes after power removal, before removing any cover. The charge lamp located within the iQpump drive should be off prior to working inside. Even if the charge lamp is off, one must measure the AC input, output, and DC Bus potential to insure safe levels prior to resuming work. Failure to adhere to this warning may result in personal injury or death.

Table 7.1 Periodic Inspections With No Power Applied

Item	Inspection	Corrective Action
External terminals, mounting bolts, connectors, etc.	Are all screws and bolts tight?	Tighten loose screws and bolts firmly.
	Are connectors tight?	Reconnect the loose connectors.
Cooling fins	Are the fins dirty or dusty?	Clean off any dirt and dust with an air gun using clean and dry air at a pressure between 55-85 psi.
Control PCB Terminal PCB Power PCB Gate Drive PCBs	Is there any conductive dirt or oil mist on the PCBs?	Clean off any dirt and dust with an air gun using clean and dry air at a pressure between 55-85 psi. Replace the boards if they cannot be made clean.
Input Diodes IPMs Output Transistors	Is there any conductive dirt or oil mist on the modules or components?	Clean off any dirt and dust with an air gun using clean and dry air at a pressure between 55-85 psi.
DC bus capacitors	Are there any irregularities, such as discoloration or odor?	Replace the capacitors or iQpump drive.

Apply power to the iQpump drive and conduct the following inspection.

Table 7.2 Periodic Inspections With Power Applied

Item	Inspection	Corrective Action
Cooling fan(s)	Is there any abnormal noise or vibration, or has the total operating time exceeded 20,000 hours. Check U1-40 for elapsed cooling fan operation time.	Replace Cooling Fan

7.2 Preventive Maintenance

Table 7.3 Preventive Maintenance

Inspection Points	Item	Check Points	Every 3-6 Months	Yearly
General	Environment	Ambient Temperature	X	
		Humidity	X	
		Dust	X	
Harmful Gas		X		
Oil Mist		X		
	Equipment	Abnormal vibration or noise	X	
	AC Power Supply	Main circuit & control voltage	X	
AC Power Circuit & Devices	Conductors & Wire Connections	Loose lugs, screws & wires		X
		Hot spots on parts		X
		Corrosion		X
		Bent conductors		X
		Breakage, cracking or discoloration		X
		Check spacing		X
	Transformers & Reactors	Discoloration or Noise	X	
	Terminal Blocks	Loose, damaged		X
DC Bus Capacitors	DC Bus Capacitors	Leakage		X
		Ruptures, broken, expansion		X
		Capacitance & insulation resistance		X
Relays & Contactors	Relays & Contactors	Noisy		X
		Contact discoloration		X
Soft Charge Resistors	Soft Charge Resistors	Cracked		X
		Discoloration		X
Control Circuits	Operation	Speed reference voltage/current		X
		I/O contact operation		X
Cooling System	Cooling Fans/Fins & Heatsink	Abnormal fan noise	X	
		Loose connectors		X
		Free of accumulation	X	
Keypad/Diplay	Digital Operator	LEDs	X	
		Monitor display values	X	
		Key functionality		X
		Clean		X

If the iQpump drive is used under the following conditions, it may be necessary to inspect more often:

- High ambient temperatures, humidity or altitudes above 3,300 feet
- Frequent starting and stopping
- Fluctuations of the AC power supply or load
- Excessive vibration and/or shock loading
- Poor environment, including dust, metal particles, salt, sulfuric acid, chlorine

7.3 Heatsink Cooling Fan Replacement

◆ Models CIMR-P7U20P4 thru 2018 (25HP @ 208V/240V) and 40P4 thru 4018 (30HP @ 480V)

A cooling fan is attached to the bottom of the iQpump drive.

If the iQpump drive is installed using the mounting holes on the back of the iQpump drive heatsink, the cooling fan can be replaced without removing the iQpump drive from the enclosure panel.

If the iQpump drive is mounted with the heatsink external to the enclosure, the cooling fan can only be replaced by removing the iQpump drive from the enclosure.

■ Removing the Heatsink Cooling Fan

1. Always turn OFF the input power before removing and installing the heatsink cooling fan.
2. Press in on the right and left sides of the fan cover in the direction of arrows “1” and then pull the fan out in the direction of arrow “2.”
3. Pull out the cable connected to the fan from the fan cover and disconnect the power connector. See [Figure 7.1](#).
4. Open the fan cover on the left and right sides in the direction of arrows “3” and remove the fan cover from the fan.

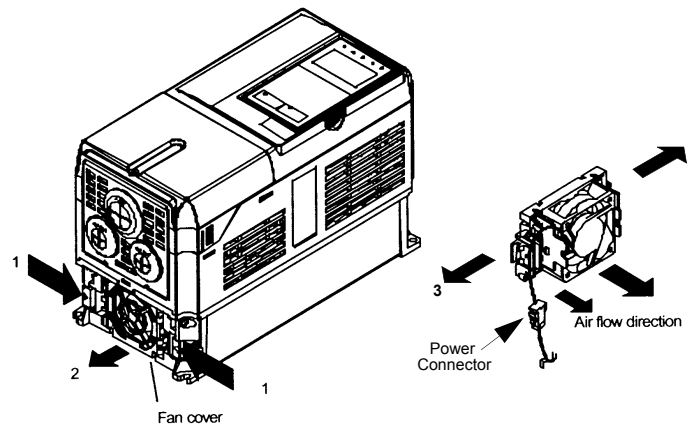

Figure 7.1 Cooling Fan Replacement Procedure

■ Installing the Heatsink Cooling Fan

1. Attach the fan cover to the cooling fan. Be sure that the air flow direction indicated by the arrows above faces into the iQpump drive.
2. Connect the power connector securely and place the power connector and cable into the fan cover.
3. Mount the fan cover on the iQpump drive. Be sure that the tabs on the sides of the fan cover click into place on the iQpump drive.

◆ Models CIMR-P7U2022 thru 2110 (30HP to 150HP @ 208V/240V) and 4024 thru 4300 (40HP to 500HP @ 480V)

A cooling fan assembly is attached to the top inside the iQpump drive. The cooling fan assembly includes the heat sink cooling fans and the internal cooling fan. The cooling fan(s) can be replaced without removing the iQpump drive from the enclosure panel.

■ Removing the Cooling Fan Assembly

1. Always turn OFF the input power before removing and installing the heatsink cooling fan assembly.
2. Remove the terminal cover, iQpump drive cover, Digital Operator, and front cover from the front of the iQpump drive.
3. Remove the Control PCB bracket (if necessary) to which the cards are mounted. Remove all cables connected to the Control PCB and remove the cooling fan power connector from the fan board (13 PCB) positioned near the top of the iQpump drive.
4. Remove the cooling fan power connectors from the gate drive board (3PCB) positioned at the back of the iQpump drive.
5. Remove the fan assembly screws and pull out the fan assembly from the iQpump drive.
6. Remove the cooling fan(s) from the fan assembly.

■ Mounting the Cooling Fan Assembly

After attaching a new cooling fan, reverse the above procedure to attach all of the components.

When attaching the cooling fan to the mounting bracket, be sure that the air flow goes toward the top of the iQpump drive.

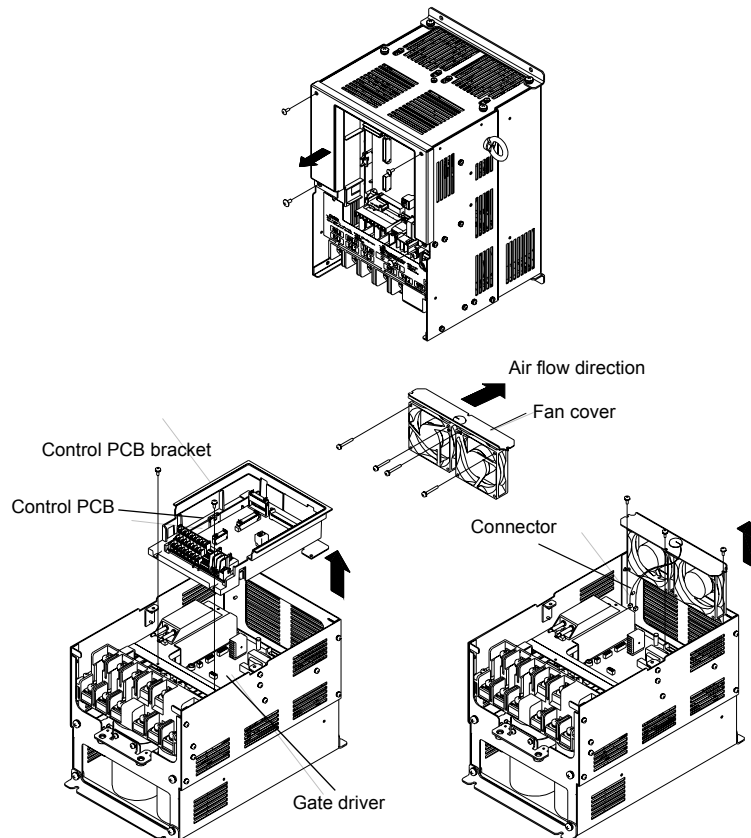

Figure 7.2 Cooling Fan Assembly Replacement Procedure

7.4 Removing and Mounting the Terminal Card

The terminal card can be removed and mounted without disconnecting the control wiring.

Note: Always confirm that input power is removed and the Charge LED is not lit before removing or mounting the terminal card.

◆ Removing the Terminal Card

1. Remove the terminal cover on the iQpump drive.
2. Remove the Digital Operator and front cover on the iQpump drive.
3. Remove the wires connected to FE and NC on the terminal card.
4. Loosen the mounting screws on the left and right sides of the terminal card until they are free. It is not necessary to remove the mounting screws completely. They are captive and self-rising.
5. Pull the terminal card out in the direction of the block arrow.

◆ Mounting the Terminal Card

Reverse the removal procedure to mount the terminal card.

Confirm that the terminal card and the Control PCB properly meet at connector CN8 before insertion.

The connector pins may be bent if the terminal card is forced into place, possibly preventing correct iQpump drive operation.

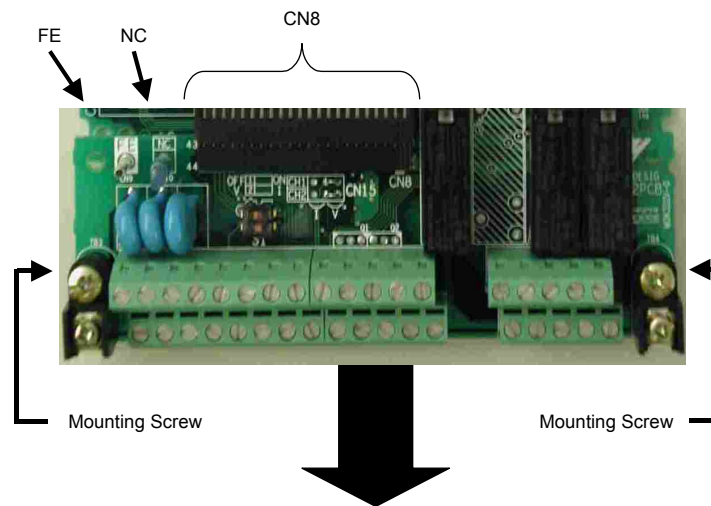

Figure 7.3 Terminal Card Removal Procedure



Appendix: A

Parameters

This appendix lists all the parameter numbers and names, along with a description of each. Also, below the parameter name in bold type is the abbreviated name as it appears on the digital operator display/keypad.

PARAMETER LIST	166
MONITOR LIST	190

Parameter List

Table 1 Parameter List

Parameter No.	Modbus Address	Parameter Name Digital Operator Display	Description	Setting Range	Factory Setting	Menu Location	Page No.
Initialization							
A1-00 ◆	0100H	Language Selection Select Language	Language selection for digital operator display. 0: English 2: Deutsch 3: Francais 4: Italiano 5: Espanol 6: Portugues *Not returned to factory setting by initialization	0 to 6	0	Programming	8
A1-01 ◆	0101H	Access Level Selection Access Level	This setting determines which parameters are accessible. 0: Operation Only 2: Advanced Level	0 or 2	2	Programming	8
A1-03	0103H	Initialize Parameters Init Parameters	Used to return all parameters to their factory or user setting. 0: No Initialize 1110: User Initialize (The user must set their own parameter default values and then parameter o2-03 must be set to "1" to save them. If the parameter values are changed after o2-03 is set to "1," the user default values can be restored by setting A1-03 to 1110.) 2220: 2-Wire Initial 3330: 3-Wire Initial	0 to 3330	0	Programming	8
A1-04	0104H	Password 1 Enter Password	When the value set into A1-04 does NOT match the value set into A1-05, parameters A1-01 thru A1-03 cannot be changed. All other parameters as determined by A1-01 can be changed. Parameter A1-05 can be accessed by pressing the MENU key while holding the RESET key.	0 to 9999	0	Programming	99
A1-05	0105H	Password 2 Select Password		0 to 9999	0	Programming	9
◆ Denotes that parameter can be changed when the drive is running. * Menu location is Pump Quick Setup when b5-01=1, and Programming when b5-01=0.							
Sequence							
b1-01	0180H	Frequency Reference Selection Reference Source	Selects the speed command (frequency reference) input source. 0: Operator - Digital preset speed d1-01 1: Terminals - Analog Input Terminal A1 (or Terminal A2 see parameter H3-13) 2: Serial Com - RS-485 terminals R+, R-, S+ and S- 3: Option PCB - Option board connected at 2CN	0 to 3	0	Pump Quick Setup	10
b1-02	0181H	Run Command Selection Run Source	Selects the run command input source. 0: Operator - "Hand" and "Off" keys on digital operator 1: Terminals - Contact Closure on Terminal S1 2: Serial Com - RS-485 terminals R+, R-, S+ and S- 3: Option PCB - Option board connected at 2CN	0 to 3	0	Pump Quick Setup	12
b1-03	0182H	Stopping Method Selection Stopping Method	Selects the stopping method when the run command is removed. 0: Ramp to Stop 1: Coast to Stop 2: DC Injection to Stop 3: Coast w/Timer (A new run command is ignored if input before the time in C1-02 expires.)	0 to 3	0	Programming	15
b1-07	0186H	Local/Remote Run Selection LOC/REM RUN Sel	0: Cycle External RUN - If the run command is closed when switching from hand (local) mode to auto (remote) mode, the Drive will not run. 1: Accept External RUN - If the run command is closed when switching from hand (local) mode to auto (remote) mode, the Drive WILL run. Note: Used with LCD Operator only.	0 or 1	0	Programming	—
b1-08	0187H	Run Command Selection During Program RUN CMD at PRG	0: Disabled - Run command accepted only in the operation menu. 1: Enabled - Run command accepted in all menus (except when b1-02 = 0).	0 or 1	0	Programming	—
b1-11	010FH	Drive Delay Time Setting Wait to Run Time	After a run command, Drive output will start after this delay time.	0 to 600	0 sec	Programming	17
DC Braking							
b2-01	0189H	DC Injection Braking Start Frequency DCInj Start Freq	Sets the frequency at which DC injection braking starts when ramp to stop (b1-03 = 0) is selected. If b2-01 < E1-09, DC injection braking starts at E1-09.	0.0 to 10.0	0.5 Hz	Programming	18
b2-02	018AH	DC Injection Braking Current DCInj Current	Selects the DC injection braking current as a percentage of the Drive rated current.	0 to 100	50%	Programming	18

Parameter No.	Modbus Address	Parameter Name Digital Operator Display	Description	Setting Range	Factory Setting	Menu Location	Page No.
b2-03	018BH	DC Injection Braking Time at Start DCInj Time @ Start	Sets the time length of DC injection braking at start in units of 1 second.	0.00 to 10.00	0.00 sec	Programming	18
b2-04	018CH	DC Injection Braking Time at Stop DCInj Time @ Stop	When b1-03 = 2 actual DC Injection time is calculated as follows: b2-04 * 10 * Output Frequency / E1-04. When b1-03 = 0, this parameter determines the amount of time DC Injection is applied to the motor at the end of the decel ramp. This should be set to a minimum of 0.50 seconds when using HSB. This will activate DC injection during the final portion of HSB and help ensure that the motor stops completely.	0.00 to 10.00	0.5 sec	Programming	18
b2-09	01E1H	Motor Pre-Heat Current Preheat Current	Motor Pre-heat current in% of Drive rated current. This is used to keep the motor warm to prevent condensation and is used in conjunction with a digital input (data = 60).	0 to 100	0%	Programming	19
Speed Search							
b3-01	0191H	Speed Search Selection SpdSrCh at Start	Enables/disables and selects the speed search function at start. 0: SpdsrchF Disable - Speed search at start is disabled (estimated speed method is used at other times) 1: SpdsrchF Enable - Speed search is enabled (estimated speed method) 2: SpdsrchI Disable - Speed search at start is disabled (current detection method is used at other times) 3: SpdsrchI Enable - Speed search is enabled (current detection method) Estimated Speed Method: Actual motor speed and direction is estimated, then the motor is ramped from that speed to the commanded speed. Current Detection Method: Current level is monitored while output frequency is ramped down.	0 to 3	2	Programming	20
b3-02	0192H	Speed Search Deactivation Current SpdSrCh Current	Used only when b3-01 = 3. Sets the speed search operation current as a percentage of Drive rated current.	0 to 200	120%	Programming	22
b3-03	0193H	Speed Search Deceleration Time SpdSrCh Dec Time	Used only when b3-01 = 3. Sets the deceleration time during speed search.	0.1 to 10.0	2.0 sec	Programming	22
b3-05	0195H	Speed Search Delay Time Search Delay	Delays the speed search operation after a momentary power loss to allow time for an external output contactor to re-energize.	0.0 to 20.0 sec	0.2 sec	Programming	22
b3-14	019EH	Bidirectional Speed Search Selection Bidir Search Sel	0: Disabled 1: Enabled	0 or 1	1	Programming	22
Delay Timers							
b4-01	01A3H	Timer Function ON-Delay Time Delay-ON Timer	Used in conjunction with a multi-function digital input and a multi-function digital output. This sets the amount of time between when the digital input is closed, and the digital output is energized.	0.0 to 3000.0	0.0 sec	Programming	23
b4-02	01A4H	Timer Function OFF-Delay Time Delay-OFF Timer	Used in conjunction with a multi-function digital input and a multi-function digital output. This sets the amount of time the output stays energized after the digital input is opened.	0.0 to 3000.0	0.0 sec	Programming	23
PI Control							
b5-01	01A5H	PI Mode Setting PI Mode	This parameter enables / disables the closed loop (PI) controller. 0: Disabled 1: Enabled (commanded speed becomes PI setpoint) 3: Fref+PI	0, 1, 3	1	Programming	25, 170
b5-02 ◆	01A6H	Proportional Gain Setting P Gain	Sets the proportional gain of the PI controller.	0.00 to 25.00	2.00	Programming	25, 170
b5-03 ◆	01A7H	Integral Time Setting PI I Time	Sets the integral time for the PI controller. A setting of zero disables integral control.	0.0 to 360.0	5.0 sec	Programming	25, 170
b5-04 ◆	01A8H	Integral Limit Setting PI I Limit	Sets the maximum output possible from the integrator. Set as a% of fmax.	0.0 to 100.0	100.0%	Programming	26
b5-06 ◆	01AAH	PI Output Limit PI Limit	Sets the maximum output possible from the entire PI controller. Set as a% of fmax.	0.00 to 100.0	100.0%	Programming	26
◆ Denotes that parameter can be changed when the drive is running. * Menu location is Quick Setting when b5-01=1, and Programming when b5-01=0.							

Parameter No.	Modbus Address	Parameter Name Digital Operator Display	Description	Setting Range	Factory Setting	Menu Location	Page No.
b5-07 ◆	01ABH	PI Offset Adjustment PI Offset	Sets the amount of offset of the output of the PI controller. Set as a% of fmax. The PI Offset Adjustment parameter has two different uses. Parameter b5-07 serves different functions depending on whether it is used on a standard PI loop or a Differential PI loop. 1: Parameter b5-07 causes an offset to be applied to the output of the PI function in a non-Differential PI loop. Every time the PI output is updated, the offset is summed with the PI output. This can be used to artificially kick-start a slow starting PI loop. 2: If the Drive is configured for Differential PI Regulation (H3-09=16), then the PI Offset is the targeted maintained differential between the signal measured on analog input A1 and the signal measured on analog input A2.	-100.0 to +100.0	0.0%	Programming	26
b5-08 ◆	01ACH	PI Primary Delay Time Constant PI Delay Time	Sets the amount of time for a filter on the output of the PI controller.	0.00 to 10.00	0.00 sec	Programming	26
b5-09	01ADH	PI Output Level Selection Output Level Sel	Determines whether the PI controller will be direct or reverse acting. 0: Normal Output (direct acting) 1: Reverse Output (reverse acting)	0 or 1	0	Programming	27
b5-10	01AEH	PI Output Gain Setting Output Gain	Sets the output gain of the PI controller.	0.0 to 25.0	1.0	Programming	27
b5-12	01B0H	PI Feedback Reference Missing Detection Selection PFb los Det Sel	0: Disabled 1: Alarm 2: Fault	0 to 2	0	Pump Quick Setup	—
b5-13	01B1H	PI Feedback Loss Detection Level Fb los Det Lvl	Sets the PI feedback loss detection level as a percentage of maximum frequency (E1-04).	0 to 100	0%	Pump Quick Setup	27
b5-14	01B2H	PI Feedback Loss Detection Time Fb los Det Time	Sets the PI feedback loss detection delay time in terms of seconds.	0.0 to 25.5	1.0 sec	Pump Quick Setup	27
b5-17	01B5H	PI Accel/Decel Time Acc/Dec Time	Applies an accel/decel time to the PI setpoint reference.	0.0 to 25.5	0.0 sec	Programming	28

◆ Denotes that parameter can be changed when the drive is running.

Energy Saving							
b8-01	01CCH	Energy Saving Control Selection Energy Save Sel	Energy Savings function enable/disable selection 0: Disabled 1: Enabled	0 or 1	0	Programming	29
b8-04	01CFH	Energy Saving Coefficient Value Energy Save COEF	Used to fine-tune the energy savings function.	0.0 to 655.00	kVA Dependent	Programming	29
b8-05	01D0H	Power Detection Filter Time kW Filter Time		0 to 2000	20 ms	Programming	29
b8-06	01D1H	Search Operation Voltage Limit Search V Limit		0 to 100	0%	Programming	29

Accel / Decel							
C1-01 ◆	0200H	Acceleration Time 1 Accel Time 1	Sets the time to accelerate from zero to maximum frequency.	0.0 to 6000.0	25.0 sec	Pump Quick Setup	30
C1-02 ◆	0201H	Deceleration Time 1 Decel Time 1	Sets the time to decelerate from maximum frequency to zero.		25.0 sec	Pump Quick Setup	30
C1-03 ◆	0202H	Acceleration Time 2 Accel Time 2	Sets the time to accelerate from zero to maximum frequency when selected via a multi-function input.		10.0 sec	Programming	30
C1-04 ◆	0203H	Deceleration Time 2 Decel Time 2	Sets the time to decelerate from maximum frequency to zero when selected via a multi-function input.		10.0 sec	Programming	30
C1-05 ◆	0204H	Acceleration Time 3 Accel Time 3	Sets the time to accelerate from zero to maximum frequency when activated by P3-12. Used for system response stabilization.		50.0 sec	Programming	30
C1-06 ◆	0205H	Deceleration Time 3 Decel Time 3	Sets the time to decelerate from maximum frequency to zero when activated by P3-12. Used for system response stabilization.		50.0 sec	Programming	30
C1-09	0208H	Fast Stop Time Fast Stop Time	Sets the time to decelerate from maximum frequency to zero for the "Fast Stop" function.		0.0 to 6000.0	10.0 sec	Programming

◆ Denotes that parameter can be changed when the drive is running.

Parameter No.	Modbus Address	Parameter Name Digital Operator Display	Description	Setting Range	Factory Setting	Menu Location	Page No.
C1-11	020AH	Accel/Decel Switch Frequency Acc/Dec SW Freq	Sets the frequency for automatic switching of accel / decel times. Fout < C1-11: Accel/Decel Time 2 Fout >= C1-11: Accel/Decel Time 1 Multi-function input "Multi-Acc/Dec 1" has priority over C1-11.	0.0 to 200.0	0.0 Hz	Programming	30
S-Curve Acc/Dec							
C2-01	020BH	S-Curve Characteristic at Accel Start SCrv Acc @ Start	<p>S-curve is used to further soften the starting ramp. The longer the S-curve time, the softer the starting ramp.</p>	0.00 to 2.50	0.20 sec	Programming	32
C2-02	020CH	S-Curve Characteristic at Accel End SCrv Acc @ End		0.00 to 2.50	0.20 sec	Programming	32
Torque Comp							
C4-01 ◆	0215H	Torque Compensation Gain Torq Comp Gain	This parameter helps to produce better starting torque. It determines the amount of torque or voltage boost based upon motor current and motor resistance.	0.00 to 2.50	1.00	Programming	33
C4-02	0216H	Torque Compensation Primary Delay Time Torq Comp Time	This parameter adjusts a filter on the output of the torque compensation function. Increase to add torque stability, decrease to improve torque response.	0 to 10000	200 ms	Programming	33
◆ Denotes that parameter can be changed when the drive is running.							
Carrier Freq							
C6-01	0223H	Normal Duty Selection Normal Duty Sel	1: Normal Duty 1 2: Normal Duty 2	1 or 2	2	Programming	34
C6-02	0224H	Carrier Frequency Selection CarrierFreq Sel	Carrier frequency sets the number of pulses per second of the output voltage waveform. 0: Low Noise (Carrier frequency is randomly modulated for lower audible noise) 1: Fc = 2.0 kHz 2: Fc = 5.0 kHz 3: Fc = 8.0 kHz 4: Fc = 10.0 kHz 5: Fc = 12.5 kHz 6: Fc = 15.0 kHz F: Program (Determined by the settings of C6-03 thru C6-05)	0 to F	kVA Dependent	Programming	34
C6-03	0225H	Carrier Frequency Upper Limit CarrierFreq Max	Maximum carrier frequency allowed when C6-02 = F.	0.4 to 15.0 kHz	kVA Dependent	Programming	34
C6-04	0226H	Carrier Frequency Lower Limit CarrierFreq Min	Minimum carrier frequency allowed when C6-02 = F.	0.4 to 15.0 kHz	kVA Dependent	Programming	34
C6-05	0227H	Carrier Frequency Proportional Gain CarrierFreq Gain	Sets the relationship of output frequency to carrier frequency when C6-02 = F.	0 to 99	0	Programming	34

Parameter No.	Modbus Address	Parameter Name Digital Operator Display	Description	Setting Range	Factory Setting	Menu Location	Page No.
Preset Reference							
d1-01 ◆	0280H	Setpoint Reference 1 Setpoint 1	Digital preset setpoint reference 1. Used when b1-01 = 0 and when in "hand" mode. Setting units are affected by P1-02.	1 to P1-03 Value	0	Programming	36
d1-02 ◆	0281H	Setpoint Reference 2 Setpoint 2	Digital preset setpoint reference 2. Selected via multi-function input terminals. Setting units are affected by P1-02.		0	Programming	36
d1-03 ◆	0282H	Setpoint Reference 3 Setpoint 3	Digital preset setpoint reference 3. Selected via multi-function input terminals. Setting units are affected by P1-02.		0	Programming	36
d1-04 ◆	0283H	Setpoint Reference 4 Setpoint 4	Digital preset setpoint reference 4. Selected via multi-function input terminals. Setting units are affected by P1-02.		0	Programming	36
d1-17 ◆	0292H	Jog Frequency Reference Jog Reference	Jog reference used when a jog is selected via the LCD operator keypad. This parameter is not available with the HOA operator. Setting units are affected by o1-03.		0	Programming	37
◆ Denotes that parameter can be changed when the drive is running.							
Reference Limits							
d2-01	0289H	Frequency Reference Upper Limit Ref Upper Limit	Determines maximum speed command, set as a percentage of parameter E1-04. If speed command is above this value, actual Drive speed will be limited to this value. This parameter applies to all speed command sources.	0.0 to 110.0	100.0%	Programming	38
d2-02	028AH	Frequency Reference Lower Limit Ref Lower Limit	Determines minimum speed command, set as a percentage of parameter E1-04. If speed command is below this value, actual Drive speed will be set to this value. This parameter applies to all speed command sources.	0.0 to 110.0	0.0%	Programming	38
d2-03	0293H	Master Speed Reference Lower Limit Ref1 Lower Limit	Determines the minimum speed command, set as a percentage of parameter E1-04. If speed command is below this value, actual Drive speed will be set to this value. This parameter only applies to analog inputs A1 and A2.	0.0 to 110.0	0.0%	Programming	38
Jump Frequencies							
d3-01	0294H	Jump Frequency 1 Jump Freq 1	These parameters allow programming of up to three prohibited frequency points for eliminating problems with resonant vibration of the motor / machine. This feature does not actually eliminate the selected frequency values, but will accelerate and decelerate the motor through the prohibited bandwidth.	0.0 to 200.0	0.0 Hz	Programming	39
d3-02	0295H	Jump Frequency 2 Jump Freq 2			0.0 Hz	Programming	39
d3-03	0296H	Jump Frequency 3 Jump Freq 3			0.0 Hz	Programming	39
d3-04	0297H	Jump Frequency Width Jump Bandwidth	This parameter determines the width of the deadband around each selected prohibited frequency point. A setting of "1.0" will result in a deadband of +/- 1.0 Hz.	0.0 to 20.0	1.0 Hz	Programming	39
V/F Pattern							
E1-01	0300H	Input Voltage Setting Input Voltage	Set to the nominal voltage of the incoming line.	155 to 255.0 (240V) 310 to 510.0 (480V)	240 V 480 V	Programming	40
E1-03	0302H	V/F Pattern Selection V/F Selection	0: 50 Hz 1: 60 Hz Saturation 2: 50 Hz Saturation 3: 72 Hz 4: 50 Hz VT1 5: 50 Hz VT2 6: 60 Hz VT1 7: 60 Hz VT2 8: 50 Hz HST1 9: 50 Hz HST2 A: 60 Hz HST1 B: 60 Hz HST2 C: 90 Hz D: 120 Hz F: Custom V/F FF: Custom w/o limit	0 to FF	F	Programming	40

Parameter No.	Modbus Address	Parameter Name Digital Operator Display	Description	Setting Range	Factory Setting	Menu Location	Page No.
E1-04	0303H	Maximum Output Frequency Max Frequency	<p>Output voltage (V)</p> <p>VMAX (E1-05) VBASE (E1-13) VA (E1-08) VMIN (E1-10)</p> <p>FMIN FA FBASE FMAX (E1-09) (E1-07) (E1-06) (E1-04)</p> <p>Frequency (Hz)</p> <p>To set V/f characteristics in a straight line, set the same values for E1-07 and E1-09. In this case, the setting for E1-08 will be disregarded. Always ensure that the four frequencies are set in the following manner: E1-04 (FMAX) ≠ E1-06 (FA) > E1-07 (FB) ≠ E1-09 (FMIN)</p>	0.0 to 120.0 Hz	60.0 Hz	Programming	41
E1-05	0304H	Maximum Output Voltage Max Voltage		0.0 to 255.0 (240V) 0.0 to 510.0 (480V)	230.0 V 460.0 V	Programming	41
E1-06	0305H	Base Frequency Base Frequency		0.0 to 200.0	60.0 Hz	Programming	42
E1-07	0306H	Mid Output Frequency A Mid Frequency A		0.0 to 200.0	3.0 Hz	Programming	42
E1-08	0307H	Mid Output Voltage A Mid Voltage A		0.0 to 255.0 (240V) 0.0 to 510.0 (480V)	17.2 VAC 34.5 VAC	Programming	42
E1-09	0308H	Minimum Output Frequency Min Frequency		0.0 to 200.0	1.5 Hz	Programming	42
E1-10	0309H	Mid Output Voltage Min Voltage		0.0 to 255.0 (240V) 0.0 to 510.0 (480V)	10.3 VAC 20.7 VAC	Programming	42
E1-11	030AH	Mid Output Frequency B Mid Frequency B		0.0 to 200.0	0.0 Hz	Programming	42
E1-12	030BH	Mid Output Voltage B Mid Voltage B		0.0 to 255.0 (240V) 0.0 to 510.0 (480V)	0.0 VAC	Programming	42
E1-13	030CH	Base Voltage Base Voltage		0.0 to 255.0 (240V) 0.0 to 510.0 (480V)	0.0 VAC	Programming	42
			Motor Setup				
E2-01	030EH	Motor Rated Current Motor Rated FLA	Set to the motor nameplate full load amps.	10% to 200%	kVA Dependent	Pump Quick Setup	45
E2-03	030FH	No-Load Current	Sets the magnetizing current of the motor.	kVA Dependent	kVA Dependent	Programming	45
E2-04	0311H	Number of Motor Poles Number of Poles	Set to the number of poles. Used for no-flow detection function and for the calculation of RPM related parameters.	2 to 48	2	Pump Quick Setup	45
E2-05	0312H	Motor Line-to-Line Resistance Term Resistance	Phase to phase motor resistance, normally set by the autotuning routine.	0.000 to 65.000	kVA Dependent	Programming	45
			Com OPT Setup				
F6-01	03A2H	Operation Selection after Communication Error Com Bus Flt Sel	Sets the stopping method for option PCB communications error (BUS fault). Active only when a communications option PCB is installed and when b1-01 or b1-02 = 3. 0: Ramp to Stop 1: Coast to Stop 2: Fast-Stop 3: Alarm Only	0 to 3	1	Programming	46
F6-02	03A3H	Input Level of External Fault from Communication Option Card EF0 Detection	0: Always detected 1: Detected only during run	0 or 1	0	Programming	46

Parameter No.	Modbus Address	Parameter Name Digital Operator Display	Description	Setting Range	Factory Setting	Menu Location	Page No.
F6-03	03A4H	Stopping Method for External Fault from Communication Option Card EF0 Fault Action	0: Ramp to Stop 1: Coast to Stop 2: Fast-Stop 3: Alarm Only	0 to 3	1	Programming	46
F6-05	03A6H	Current Monitor Display Unit Selection Current Unit Sel	0: A Display 1: 100%/8192 (Drive Rated Current)	0 or 1	0	Programming	46
			Digital Inputs				
H1-01	0400H	Terminal S3 Function Selection Terminal S3 Sel	0: 3-wire control FWD/REV selection for 3-wire sequence 1: Local/Remote Sel Hand/Auto Selection - Closed = Hand, Open = Auto. 2: Option/Inv Sel Selects source of speed command and sequence. Closed = b1-01 & b1-02, Open = Option Card 3: Multi-Step SP1 Closed = speed command from d1-02 or Aux Terminal. Open = speed command determined by b1-01. 4: Multi-Step SP2 Closed = speed command from d1-03 or d1-04. Open = speed command determined by b1-01. 7: Multi-Acc/Dec 1 Closed = Accel & Decel Ramps determined by C1-03 & C1-04. Open = Accel & Decel Ramps determined by C1-01 & C1-02. 8: Ext BaseBlk N.O. Closed = Output transistors forced off, Open = Normal operation. 9: Ext BaseBlk N.C. Closed = Normal Operation, Open = Output transistors forced off. A: Acc/Dec RampHold Closed = Acceleration suspended and speed held, Open = Normal Operation. C: Term A2 Enable Closed = Terminal A2 is active, Open = Terminal A2 is disabled. F: Term Not Used Terminal has no effect. 10: MOP Increase Closed = Speed Command Increases, Open = Speed Command Held. Must be set in conjunction with MOP Decrease and b1-02 must be set to 1. 11: MOP Decrease Closed = Speed Command Decreases, Open = Speed Command Held. Must be set in conjunction with MOP Increase and b1-02 must be set to 1. 14: Fault Reset Closed = Resets the Drive after the fault and the run command have been removed. 15: Fast-Stop N.O. Closed = Drive decelerates using C1-09, regardless of run command status. 17: Fast-Stop N.C. Closed = Normal operation. Open = Drive decelerates using C1-09, regardless of run command status. 18: Timer Function Input for independent timer, controlled by b4-01 and b4-02. Used in conjunction with a multi-function digital output. 19: PI Disable Turns off the PI controller, and PI setpoint becomes speed command. 1B: Program Lockout Closed = All parameter settings can be changed. Open = Only speed command at U1-01 can be changed.	0 to 87	24	Programming	47
H1-02	0401H	Terminal S4 Function Selection Terminal S4 Sel		0 to 87	14	Programming	47
H1-03	0402H	Terminal S5 Function Selection Terminal S5 Sel		0 to 87	3: 2-wire 0: 3-wire	Programming	47

Parameter No.	Modbus Address	Parameter Name Digital Operator Display	Description	Setting Range	Factory Setting	Menu Location	Page No.
H1-04	0403H	Terminal S6 Function Selection Terminal S6 Sel	<p>20: External Pump Fault, Normally Open, Always Detected, Ramp To Stop</p> <p>21: External Pump Fault, Normally Closed, Always Detected, Ramp To Stop</p> <p>22: External Pump Fault, Normally Open, During Run, Ramp To Stop</p> <p>23: External Pump Fault, Normally Closed, During Run, Ramp To Stop</p> <p>24: External Pump Fault, Normally Open, Always Detected, Coast To Stop</p> <p>25: External Pump Fault, Normally Closed, Always Detected, Coast To Stop</p> <p>26: External Pump Fault, Normally Open, During Run, Coast To Stop</p> <p>27: External Pump Fault, Normally Closed, During Run, Coast To Stop</p> <p>28: External Pump Fault, Normally Open, Always Detected, Fast-Stop</p> <p>29: External Pump Fault, Normally Open, Always Detected, Fast-Stop</p> <p>2A: External Pump Fault, Normally Open, During Run, Fast-Stop</p> <p>2B: External Pump Fault, Normally Closed, During Run, Fast-Stop</p> <p>2C: External Pump Fault, Normally Open, Always Detected, Alarm Only</p> <p>2D: External Pump Fault, Normally Closed, Always Detected, Alarm Only</p> <p>2E: External Pump Fault, Normally Open, During Run, Alarm Only</p> <p>2F: External Pump Fault, Normally Closed, During Run, Alarm Only</p> <p>30: PID Integral Reset</p> <p>31: PID Integral Hold</p> <p>34: PI SFS Cancel.</p> <p>35: Input Level Sel</p> <p>36: Option/Inv Sel 2</p> <p>Selects source of speed command and sequence. Closed = Option Card, Open = b1-01 & b1-02.</p> <p>60: Motor Preheat Applies current to create heat to avoid condensation. Closed = Apply amount of current as set in parameter b2-09.</p> <p>61: Speed Search 1 When closed as a run command is given, Drive does a speed search starting at maximum frequency (E1-04). (Current detection.)</p> <p>62: Speed Search 2 When closed as a run command is given, Drive does a speed search starting at speed command. (Current detection.)</p> <p>64: Speed Search 3</p> <p>67: Com Test Mode - Used to test RS-485/422 interface. Direction determined by fwd/rev input. 3-wire control Only.</p> <p>6A: Drive Enable - Closed = Drive will accept run command. Open = Drive will not run. If running, Drive will stop per b1-03.</p> <p>6B: Com/Inv Sel - Selects source of speed command and sequence Closed = Serial Communication (R+,R-,S+,S-), Open = b1-01 & b1-02</p> <p>6C: Com/Inv Sel 2</p> <p>80: Hand Mode Function Active in Stopped and Auto Mode. Closed: Hand mode operation as defined in P1-14. Open: Stop Mode when with no incoming run command.</p> <p>Note: Input not active when b1-02 is set for 0 – Operator.</p> <p>81: Disable Sleep Mode Function Active in Auto Mode. Closed: Disables sleep function, Feedback Drop Detection and Over cycle protection. Open: Sleep function, Feedback Drop Detection and Over cycle protection enabled.</p> <p>82: Sleep Activation Active in Auto Mode. Closed: Drive will go to sleep (External Digital Input). Open: No function.</p>	0 to 87	80	Programming	47

Parameter No.	Modbus Address	Parameter Name Digital Operator Display	Description	Setting Range	Factory Setting	Menu Location	Page No.
H1-05	0404H	Terminal S7 Function Selection Terminal S7 Sel	<p>83: Thermostat Fault, Function Active in Auto Mode. Closed: Drive will trip on "Thermostat Fault". Open: Thermostat fault not active.</p> <p>Open: Low Water Level Fault.</p> <p>84: Pre-charge Closed: Disables pre-charge function. Open: Pre-charge function enabled.</p> <p>85: Low Water Level Function Active in Auto Mode during normal operation, also used with pre-charge function. Function logic depends on parameter P1-15 (Low Water Input). P1-15 = 0 (Closed @ Low Water). Closed: Low Water Level Fault. Open: Reservoir/Tank is filled to normal level.</p> <p>P1-15 = 1 (Open @ Low Water). Closed: Reservoir/Tank is filled to normal level. Pre-charge function: Function uses low water level input as "Tank/Reservoir" feedback to indicate water level reached.</p> <p>86: Fixed Speed Auto Function Active in Auto Mode Only, Pre-Charge and Thrust Bearing function have a higher priority. When fixed speed auto is active (closed) drive disabled Sleep Mode and Lead/Lag operation. Closed: Drive runs at P3-02 frequency, PI Control disabled Open: Drive runs normal operation auto mode.</p> <p>87: Thermostat Fault, Normally Closed <0032> Function Active in Auto Mode. Closed: Thermostat fault not active. Open: Drive will trip on "Thermostat Fault".</p>	0 to 87	84	Programming	47

Parameter No.	Modbus Address	Parameter Name Digital Operator Display	Description	Setting Range	Factory Setting	Menu Location	Page No.
Digital Outputs							
H2-01	040BH	Terminal M1-M2 Function Selection Term M1-M2 Sel	<p>0: During RUN 1 = Closed when a run command is input or the Drive is outputting voltage.</p> <p>1: Zero Speed = Closed when Drive output frequency is less than Fmin (E1-09).</p> <p>2: Fref/Fout Agree 1 = Closed when Drive output speed equals the speed command within the bandwidth of L4-02.</p> <p>3: Fref/Set Agree 1 = Closed when the Drive output speed and the speed command are equal to the value in L4-01 within the bandwidth of L4-02.</p> <p>4: Freq Detect 1 = Closed when the Drive output speed is less than or equal to the value in L4-01, with hysteresis determined by L4-02.</p> <p>5: Freq Detect 2 = Closed when the Drive output speed is greater than or equal to the value in L4-01, with hysteresis determined by L4-02.</p> <p>6: Inverter Ready = Closed when the Drive is not in a fault state, and not in program mode.</p> <p>7: DC Bus Undervolt = Closed when the DC bus voltage falls below the UV trip level (L2-05).</p> <p>8: Base Blk 1 = Closed when the Drive is not outputting voltage.</p> <p>9: Operator Reference = Closed when the speed command is coming from the digital operator.</p> <p>A: Remote/Auto Oper = Closed when the run command is coming from the digital operator.</p> <p>B: Trq Det 1 N.O. - Closes when the output current exceeds the value set in parameter L6-02 for more time than is set in parameter L6-03.</p> <p>C: Loss of Ref - Closes when the Drive has detected a loss of analog speed command.</p> <p>Speed command is considered lost when it drops 90% in 0.4 seconds. Parameter L4-05 determines Drive reaction to a loss of speed command.</p> <p>D: DB Overheat.</p> <p>E: Fault - Closes when the Drive experiences a major fault.</p> <p>F: Not Used</p> <p>10: Minor Fault - Closes when Drive experiences a minor fault or alarm.</p> <p>11: Reset Cmd Active - Closes when the Drive receives a reset command from terminals or serial comms.</p> <p>12: Timer Output - Output for independent timer, controlled by b4-01 and b4-02.</p> <p>Used in conjunction with a multi-function digital input.</p> <p>17: Trq. Det 1 N.C. - Opens when the output current exceeds the value set in parameter L6-02 for more time than is set in parameter L6-03.</p> <p>1A: Reverse Dir - Closes when the Drive is running in the reverse direction.</p> <p>1E: Restart Enabled - Closes when the Drive is performing an automatic restart.</p> <p>Automatic restart is configured by parameter L5-01.</p> <p>1F: Overload (OL1) - Closes before a motor overload occurs. (90% of OL1 time).</p> <p>20: OH Prealarm - Closes when the Drive's heatsink temperature exceeds the setting of parameter L8-02.</p> <p>38: Drive Enable - Closes when the Drive enable input is active.</p> <p>39: Waiting to Run - Closes during the time after a run command is issued, but the Drive is not running due to the time set in parameter b1-10.</p> <p>3A: OH Freq Reduce</p> <p>3B: Run Src Com/Opt</p> <p>3D: Cooling Fan Err = Closed during internal cooling fan failure.</p> <p>40: Pump 2 Control</p> <p>Open: Shutdown Additional Pump 2.</p> <p>Closed: Start Additional Pump 2.</p> <p>Function Active in multiplex mode.</p> <p>Contact control for second pump.</p> <p>41: Pump 3 Control</p> <p>Open: Shutdown Additional Pump 3.</p> <p>Closed: Start Additional Pump 3.</p> <p>Function Active in multiplex mode.</p> <p>Contact control for second pump.</p>	0 to 42	40	Programming	63
H2-02 (continued on next page)	040CH	Terminal M3-M4 Function Selection Term M3-M4 Sel	<p>13: Trq. Det 1 N.O. - Closes when the output current exceeds the value set in parameter L6-02 for more time than is set in parameter L6-03.</p> <p>14: Loss of Ref - Closes when the Drive has detected a loss of analog speed command.</p> <p>Speed command is considered lost when it drops 90% in 0.4 seconds. Parameter L4-05 determines Drive reaction to a loss of speed command.</p> <p>15: DB Overheat.</p> <p>16: Fault - Closes when the Drive experiences a major fault.</p> <p>17: Not Used</p> <p>18: Minor Fault - Closes when Drive experiences a minor fault or alarm.</p> <p>19: Reset Cmd Active - Closes when the Drive receives a reset command from terminals or serial comms.</p> <p>20: Timer Output - Output for independent timer, controlled by b4-01 and b4-02.</p> <p>Used in conjunction with a multi-function digital input.</p> <p>21: Trq. Det 1 N.C. - Opens when the output current exceeds the value set in parameter L6-02 for more time than is set in parameter L6-03.</p> <p>22: Reverse Dir - Closes when the Drive is running in the reverse direction.</p> <p>23: Restart Enabled - Closes when the Drive is performing an automatic restart.</p> <p>Automatic restart is configured by parameter L5-01.</p> <p>24: Overload (OL1) - Closes before a motor overload occurs. (90% of OL1 time).</p> <p>25: OH Prealarm - Closes when the Drive's heatsink temperature exceeds the setting of parameter L8-02.</p> <p>38: Drive Enable - Closes when the Drive enable input is active.</p> <p>39: Waiting to Run - Closes during the time after a run command is issued, but the Drive is not running due to the time set in parameter b1-10.</p> <p>3A: OH Freq Reduce</p> <p>3B: Run Src Com/Opt</p> <p>3D: Cooling Fan Err = Closed during internal cooling fan failure.</p> <p>40: Pump 2 Control</p> <p>Open: Shutdown Additional Pump 2.</p> <p>Closed: Start Additional Pump 2.</p> <p>Function Active in multiplex mode.</p> <p>Contact control for second pump.</p> <p>41: Pump 3 Control</p> <p>Open: Shutdown Additional Pump 3.</p> <p>Closed: Start Additional Pump 3.</p> <p>Function Active in multiplex mode.</p> <p>Contact control for second pump.</p>	0 to 42	41	Programming	63

Parameter No.	Modbus Address	Parameter Name Digital Operator Display	Description	Setting Range	Factory Setting	Menu Location	Page No.
H2-02 (continued)	040CH	Terminal M3-M4 Function Selection Term M3-M4 Sel	42: Pump Fault Function Active in hand, auto, pre-charge and thrust mode Open: No Dedicated Pump Faults are active. Closed: Dedicated pump fault active (Low Feedback Fault, High Feedback Fault, Over Cycling Fault, Pump Protection Fault, Thermostat Fault, Low Water Fault, Ext. Pump Fault).	0 to 42	41	Programming	63
Analog Inputs							
H3-02 ◆	0411H	Terminal A1 Gain Setting Terminal A1 Gain	Sets the speed command when 10 V is input, as a percentage of the maximum output frequency (E1-04).	0.0 to 1000.0	100.0%	Programming	70
H3-03 ◆	0412H	Terminal A1 Bias Setting Terminal A1 Bias	Sets the speed command when 0 V is input, as a percentage of the maximum output frequency (E1-04).	-100.0 to +100.0	0.0%	Programming	70
H3-08	0417H	Terminal A2 Signal Level Selection Term A2 Signal	Selects the signal level of terminal A2. 0: 0 - 10 Vdc (switch S1-2 must be in the off position) 2: 4 - 20 mA (switch S1-2 must be in the on position)	0 or 2	2	Programming	71
H3-09	0418H	Aux Terminal Function Selection Terminal A2 Sel	Selects what effect the aux terminal has on the Drive. 0: Frequency Bias - 0 - 100% bias 2: Aux Reference B: PI Feedback D: Frequency Bias 2 - 0 - 100% bias E: Motor Temperature - See parameters L1-03 & L1-04 16: PI Differential 1F: Not Used	0 to 1F	B**	Programming	72
H3-10 ◆	0419H	Terminal A2 Gain Setting Terminal A2 Gain	Sets the percentage when 10 V (20 mA) is input.	0.0 to 1000.0	100.0%	Programming	76
H3-11 ◆	041AH	Terminal A2 Bias Setting Terminal A2 Bias	Sets the percentage when 0 V (4 mA) is input.	-100.0 to +100.0	0.0%	Programming	76
H3-12	041BH	Analog Input Filter Time Constant Filter Avg Time	Used to “smooth” out erratic or noisy analog input signals.	0.00 to 2.00	0.30 sec	Programming	76
H3-13	041CH	Master Frequency Reference Terminal SelectionTA1/ A2 Select	Determines which terminal will be the main reference source. 0: Main Fref TA1 - Terminal TA1 is the main speed command and Terminal TA2 is the Aux speed command. 1: Main Fref TA2 - Terminal TA2 is the main speed command and Terminal TA1 is the Aux speed command. Only effective when H3-09 is set to 2 “Aux Reference”.	0 or 1	0	Programming	76
◆ Denotes that parameter can be changed when the drive is running. ** Factory setting changes to “B” when b5-01 = 1.							
Analog Outputs							
H4-01	041DH	Terminal FM Monitor Selection Terminal FM Sel	Selects which monitor will be output on terminals FM and AC. 1: Frequency Ref (100% = max. output frequency) 2: Output Freq (100% = max. output frequency) 3: Output Current (100% = Drive rated current) 6: Output Voltage (100% = 230 V or 100% = 460 V) 7: DC Bus Voltage (100% = 400 V or 100% = 800 V) 8: Output kWatts (100% = Drive rated power) 15: Term A1 Level 16: Term A2 Level 18: Mot SEC Current (100% = Motor rated secondary current) 20: SFS Output (100% = max. output frequency) 24: PI Feedback 31: Not Used 36: PI Input 37: PI Output (100% = max. output frequency) 38: PI Setpoint Note: 100% = 10 V DC output * FM gain setting (H4-02).	1 to 38 <0032>	2	Programming	77
H4-02 ◆	041EH	Terminal FM Gain Setting Terminal FM Gain	Sets terminal FM output voltage (in percent of 10 V) when selected monitor is at 100% output.	0.0 to 1000.0	100.0%	Programming	78
H4-03 ◆	041FH	Terminal FM Bias Setting Terminal FM Bias	Sets terminal FM output voltage (in percent of 10 V) when selected monitor is at 0% output.	-110.0 to 110.0	0.0%	Programming	78

Parameter No.	Modbus Address	Parameter Name Digital Operator Display	Description	Setting Range	Factory Setting	Menu Location	Page No.
H4-04	0420H	Terminal AM Monitor Selection Terminal AM Sel	Selects which monitor will be output on terminals AM and AC. 1: Frequency Ref (100% = max. output frequency) 2: Output Freq (100% = max. output frequency) 3: Output Current (100% = Drive rated current) 6: Output Voltage (100% = 230 V or 100% = 460 V) 7: DC Bus Voltage (100% = 400 V or 100% = 800 V) 8: Output kWatts (100% = Drive rated power) 15: Term A1 Level 16: Term A2 Level 18: Mot SEC Current (100% = Motor rated secondary current) 20: SFS Output (100% = max. output frequency) 24: PI Feedback 31: Not Used 36: PI Input 37: PI Output (100% = max. output frequency) 38: PI Setpoint Note: 100% = 10 V DC output * AM gain setting (H4-05).	1 to 38 <0032>	8	Programming	79
H4-05 ◆	0421H	Terminal AM Gain Setting Terminal AM Gain	Sets terminal AM output voltage (in percent of 10 V) when selected monitor is at 100% output.	0.0 to 1000.0	50.0%	Programming	79
H4-06 ◆	0422H	Terminal AM Bias Setting Terminal AM Bias	Sets terminal AM output voltage (in percent of 10 V) when selected monitor is at 0% output.	-110.0 to 110.0	0.0%	Programming	79
H4-07	0423H	Terminal FM Signal Level Selection AO Level Select1	0: 0 - 10 Vdc 2: 4-20 mA*	0 or 2	0	Programming	80
H4-08	0424H	Terminal AM Signal Level Selection AO Level Select2	0: 0 - 10 Vdc 2: 4-20 mA* * An analog output of 4 - 20 mA cannot be used with the standard terminal board. Therefore an optional terminal board (with shunt connector CN15) is needed.	0 or 2	0	Programming	80

◆ Denotes that parameter can be changed when the drive is running.

Serial Com Setup							
H5-01	0425H	Drive Node Address Serial Com Adr	Selects Drive station node number (address) for terminals R+, R-, S+, S-.* Note: An address of "0" disables serial com.	0 to 20 (H5-08=0) 0 to FF (H5-08=1) 0 to 63 (H5-08=2)	1F	Programming	93
H5-02	0426H	Communication Speed Selection Serial Baud Rate	Selects the baud rate for terminals R+, R-, S+ and S-.* 0: 1200 Baud 1: 2400 Baud 2: 4800 Baud (APOGEE FLN) 3: 9600 Baud (Metasys N2) 4: 19200 Baud	0 to 4	3	Programming	93
H5-03	0427H	Communication Parity Selection Serial Com Sel	Selects the communication parity for terminals R+, R-, S+ and S-.* 0: No Parity 1: Even Parity 2: Odd Parity	0 to 2	0	Programming	93
H5-04	0428H	Stopping Method after Communication Error Serial Fault Sel	Selects the stopping method when a communication error is detected. 0: Ramp to Stop 1: Coast to Stop 2: Fast-Stop 3: Alarm Only	0 to 3	3	Programming	94
H5-05	0429H	Communication Error Detection Selection Serial Flt Dct	Enables or disables the communications timeout detection function. 0: Disabled - A communications loss will NOT cause a communications fault. 1: Enabled - If communications are lost for more than the time specified in parameter H5-09, a communications fault will occur.	0 or 1	1	Programming	94
H5-06	042AH	Drive Transmit Wait Time Transmit WaitTIM	Sets the time from when the Drive receives data to when the Drive sends data.	5 to 65	5 ms	Programming	94
H5-07	042BH	RTS Control Selection RTS Control Sel	Enables or disables "request to send" (RTS) control: 0: Disabled (RTS is always on) 1: Enabled (RTS turns on only when sending)	0 or 1	1	Programming	94

Parameter No.	Modbus Address	Parameter Name Digital Operator Display	Description	Setting Range	Factory Setting	Menu Location	Page No.
H5-09	0435H	Communication Error Detection Time CE Detect Time	Determines how long communications must be lost before a fault is annunciated. Works in conjunction with parameters H5-05 and H5-04.	0.0 to 10.0 (H5-08=0) 0.0 to 10.0 (H5-08=1) 0.0 to 90.0 (H5-08=2)	2.0 sec	Programming	94
Motor Overload							
L1-01	0480H	Motor Overload Protection Selection MOL Fault Select	Enables or disables the motor thermal overload protection. 0: Disabled 1: Std Fan Cooled (Enabled) 2: Std Blower Cooled 3: Vector Motor	0 to 1	1	Programming	96
L1-02	0481H	Motor Overload Protection Time MOL Time Const	Determines how much time will elapse prior to a motor overload fault (OL1), when motor amps exceed the value set in parameter E2-01 by 10%. Actual (OL1) trip time will vary depending on severity of overload.	0.1 to 20.0	8.0min	Programming	96
L1-03	0482H	Motor Overheat Alarm Operation Selection Mtr OH Alarm Sel	Operation selection when the motor temperature analog input (H3-09 = E) exceeds the OH3 alarm level (1.17 V) 0: Ramp to Stop 1: Coast to Stop 2: Fast-Stop 3: Alarm Only	0 to 3	3	Programming	97
L1-04	0483H	Motor Overheat Fault Operation Selection Mtr OH Fault Sel	Stopping method when the motor temperature analog input (H3-09 = E) exceeds the OH4 level (2.34 V). 0: Ramp to Stop 1: Coast to Stop 2: Fast-Stop	0 to 2	1	Programming	97
L1-05	0484H	Motor Temperature Input Filter Time Mtr Temp Filter	Delay Time applied to motor temperature analog input (H3-09 = E) for filtering purposes.	0.00 to 10.00	0.20 sec	Programming	97
PwrLoss Ridethru							
L2-01	0485H	Momentary Power Loss Detection Selection PwrL Selection	Enables and disables the momentary power loss function. 0: Disabled - Drive trips on (UV1) fault when power is lost. 1: PwrL Ride Thru t - Drive will restart if power returns within the time set in L2-02.* 2: CPU Power Active - Drive will restart if power returns prior to internal power supply shut down.* * In order for a restart to occur, the run command must be maintained throughout the ride thru period.	0 to 2	2	Programming	99
L2-02	0486H	Momentary Power Loss Ride-thru Time PwrL Ridethru t	Determines the power loss ride-thru time. This value is dependent on the capacity of the Drive. Only effective when L2-01 = 1.	0.0 to 25.5 sec	kVA Dependent	Programming	99
L2-03	0487H	Momentary Power Loss Minimum Base Block Time PwrL Baseblock t	Used to allow the residual motor voltage to decay before the Drive output turns back on. After a power loss, if L2-03 is greater than L2-02, operation resumes after the time set in L2-03.	0.1 to 5.0 sec	kVA Dependent	Programming	99
L2-04	0488H	Momentary Power Loss Voltage Recovery Ramp Time PwrL V/F Ramp t	The time it takes the output voltage to return to the preset V/f pattern after speed search (current detection mode) is complete.	0.0 to 5.0 sec	kVA Dependent	Programming	100
L2-05	0489H	Undervoltage Detection Level PUV Det Level	Sets the Drive's DC Bus undervoltage trip level. If this is set lower than the factory setting, additional AC input reactance or DC bus reactance may be necessary.	Voltage Class Dependent	Voltage Class Dependent	Programming	100
Stall Prevention							
L3-01	048FH	Stall Prevention Selection During Accel StallP Accel Sel	0: Disabled (Motor accelerates at active acceleration, C1-01 or C1-03. The motor may stall if load is too heavy or accel time is too short.) 1: General Purpose (When output current exceeds L3-02 level, acceleration stops. It starts to accelerate at current value recovery.) 2: Intelligent (The active acceleration rate, C1-01 or C1-02, is ignored. Acceleration is completed in the shortest amount of time w/o exceeding the current value set in L3-02.	0 to 2	1	Programming	101
L3-02	0490H	Stall Prevention Level During Accel StallP Accel Lvl	This function is enabled when L3-01 is "1" or "2". Drive rated current is 100%. Decrease the set value if stalling occurs at factory setting.	0 to 200	120%	Programming	101

Parameter No.	Modbus Address	Parameter Name Digital Operator Display	Description	Setting Range	Factory Setting	Menu Location	Page No.
L3-04	0492H	Stall Prevention Selection During Decel StallP Decel Sel	0: Disabled (The Drive decelerates at the active deceleration rate, C1-02 or C1-04. If the load is too large or the deceleration time is too short, an OV fault may occur.) 1: General Purpose (The Drive decelerates at the active deceleration rate, C1-02 or C1-04, but if the main circuit DC bus voltage reaches the stall prevention level the output frequency will clamp. Deceleration will continue once the DC bus level drops below the stall prevention level.) 2: Intelligent (The active deceleration rate is ignored and the Drive decelerates as fast as possible w/o hitting OV fault level.)	0 to 3	1	Programming	102
L3-05	0493H	Stall Prevention Level During Decel StallP Run Sel	0: Disabled (Drive runs a set frequency.) A heavy load may cause the Drive to trip on an OC fault. 1: Decel Time 1 (In order to avoid stalling during heavy loading, the Drive will start to decelerate at Decel time 1 (C1-02) if the output current exceeds the level set by L3-06. Once the current level drops below the L3-06 level the Drive will accelerate back to its set frequency at the active acceleration rate.) 2: Decel Time 2 (Same as setting 1 except the Drive decelerates at Decel Time 2 (C1-04).) For 6 Hz or less frequency, stall prevention function during run is disabled regardless of L3-05 set.	0 to 2	1	Programming	103
L3-06	0494H	Stall Prevention Level During Running StallP Run Level	This function is enabled when L3-05 is "1" or "2". Drive rated current is set as 100%. Normally, changing the setting is not required. Decrease the set value if stalling occurs at factory setting.	30 to 200	120%	Programming	103
Ref Detection							
L4-01	0499H	Speed Agreement Detection Level Spd Agree Level	L4-01 and L4-02 are used in conjunction with the multi-function outputs, (H2-01 and H2-02) as a setpoint and hysteresis for a contact closure.	0.0 to 200.0	0.0 Hz	Programming	104
L4-02	049AH	Speed Agreement Detection Width Spd Agree Width		0.0 to 20.0	2.0 Hz	Programming	104
L4-05	049DH	Frequency Reference Loss Detection Selection Ref Loss Sel	Determines how the Drive will react when the frequency reference is lost. 0: Stop (Disabled) - Drive will not run at the frequency reference. 1: Enabled @ % of PrevRef - Drive will run at a percentage (L4-06) of the frequency reference level at the time frequency reference was lost. Note: Only available in the Hand Mode (P5-01 = 0).	0 or 1	0	Programming	105
L4-06	04C2H	Frequency Reference Level at Loss Frequency Fref at Floss	If Frequency Reference loss function is enabled (L4-05 = 1) and Frequency Reference is lost, then the Drive will run at reduced frequency reference determined by L4-06. New Fref=Fref at time of loss x L4-06. Note: Only available in the Hand Mode (P5-01 = 0)	0 or 1	0	Programming	105
Fault Restart							
L5-01	049EH	Number of Auto Restart Attempts Num of Restarts	Determines the number of times the Drive will perform an automatic restart.	0 to 10	0	Pump Quick Setup	105
L5-02	049FH	Auto Restart Operation Selection Restart Sel	Determines if the fault contact activates during an automatic restart attempt. 0: No Flt Relay - fault contact will not activate during an automatic restart. 1: Flt Relay Active - fault contact will activate during an automatic restart.	0 or 1	0	Programming	105
L5-03	04A0H	Maximum Restart Time After Fault Max Restart Time	If the restart fails (or is not attempted due to a continuing fault condition, e.g. an OV fault) the Drive waits the Maximum Restart Time After Fault (L5-03) before attempting another restart. This parameter is not applicable to Loss of Prime Fault.	10.0 to 3600.0 <0032>	180.0 sec	Pump Quick Setup	105

Parameter No.	Modbus Address	Parameter Name Digital Operator Display	Description	Setting Range	Factory Setting	Menu Location	Page No.
Torque Detection							
L6-01	04A1H	Torque Detection Selection 1 Load Detection	Determines the Drive's response to an overtorque / undertorque condition. Overtorque and Undertorque are determined by the settings in parameters L6-02 and L6-03. 0: Disabled 1: OL@SpdAgree - Alm (Overtorque Detection only active during Speed Agree and Operation continues after detection) 2: OL At RUN - Alm (Overtorque Detection is always active and operation continues after detection) 3: OL@SpdAgree - Flt (Overtorque Detection only active during Speed Agree and Drive output will shut down on an OL3 fault.) 4: OL At RUN - Flt (Overtorque Detection is always active and Drive output will shut down on an OL3 fault.) 5: LL@SpdAgree - Alm (Undertorque Detection is only active during Speed Agree and operation continues after detection.) 6: LL at RUN - Alm (Undertorque Detection is always active and operation continues after detection.) 7: LL @ SpdAgree - Flt (Undertorque Detection only active during Speed Agree and Drive output will shut down on an OL3 fault.) 8: LL At RUN - Flt (Undertorque Detection is always active and Drive output will shut down on an OL3 fault.)	0 to 8	0	Programming	107
L6-02	04A2H	Torque Detection Level 1 Load Det Lvl	Sets the overtorque/undertorque detection level as a percentage of Drive rated current.	0 to 300	15%	Programming	107
L6-03	04A3H	Torque Detection Time 1 Loss Det Time	Sets the length of time an overtorque / undertorque condition must exist before being recognized by the Drive. OL3 is then displayed.	0.0 to 10.0	10.0 sec	Programming	107
Hdwe Protection							
L8-01	04ADH	Internal Dynamic Braking Resistor Protection Selection DB Resistor Prot	0: Not Provided 1: Provided	0 or 1	0	Programming	109
L8-02	04AEH	Overheat Pre-Alarm Level OH Pre-Alarm Lvl	When the cooling fin temperature exceeds the value set in this parameter, an overheat pre-alarm (OH) will occur.	50 to 130	95°C	Programming	109
L8-03	04AFH	Overheat Pre-Alarm Operation Selection OH Pre-Alarm Sel	Drive Operation upon OH Pre Alarm Detection. 0: Ramp to Stop (Decel Time C1-02). 1: Coast to Stop 2: Fast-Stop (Decel Time = C1-09). 3: Alarm Only *0 to 2 is recognized as fault detection, and 3 is recognized as alarm. (For the fault detection, the fault contact operates.) 4: OH Alarm & Reduce (Continue operation and reduce output frequency by L8-19)	0 to 4	4	Programming	109
L8-05 <0033>	04B1H	Input Phase Loss Protection Selection Ph Loss In Sel	Selects the detection of input current phase loss, power supply voltage imbalance, or main circuit electrostatic capacitor deterioration. 0: Disabled 1: Enabled	0 to 1	1	Programming	110
L8-06	04B2H	Input Phase Loss Detection Level Ph Loss In Lvl	Monitors the DC Bus current ripple and activates when one of the input phases is lost (PF).	0.0 to 25.0	0.5%	Programming	110
L8-07 <0033>	04B3H	Output Phase Loss Protection Selection Ph Loss Out Sel	Selects the detection of output current open-phase. When applied motor capacity is too small for Drive capacity, output phase loss may be detected inadvertently. In this case, set to 0. 0: Disabled 1: Enabled	0 to 1	1	Programming	110
L8-09	04B5H	Output Ground Fault Detection Selection Ground Fault Sel	Enables and disables Drive output ground fault detection. 0: Disabled 1: Enabled	0 or 1	1	Programming	110
L8-10	04B6H	Heatsink Cooling Fan Operation Selection Fan On/Off Sel	Controls the Heatsink Cooling Fan Operation. 0: Fan On-Run Mode (Fan will operate only when Drive is running and for L8-11 seconds after RUN is removed). 1: Fan Always On (Cooling fan operates whenever Drive is powered up.)	0 or 1	0	Programming	110
L8-11 <0032>	04B7H	Heatsink Cooling Fan Operation Delay Time Fan Delay Time	When L8-10=0 this parameter sets a delay time for Cooling Fan de-energization after the run command is removed or baseblock enabled.	0 to 300	300 sec	Programming	111

Parameter No.	Modbus Address	Parameter Name Digital Operator Display	Description	Setting Range	Factory Setting	Menu Location	Page No.								
L8-12	04B8H	Ambient Temperature Setting Ambient Temp	When the Drive is installed in an ambient temperature exceeding its rating, Drive overload (OL2) protection level is reduced.	45 to 60°C	45°C	Programming	111								
L8-15	04BBH	OL2 Characteristic Selection at Low Speeds OL2 Sel @ L-Spd	This parameter assists in protecting the output transistor junctions from overheating when output current is high and output frequency is low. 0: Disabled 1: Enabled (L8-18 is active)	0 or 1	1	Programming	111								
L8-18	04BEH	Soft CLA Selection Soft CLA Sel	Enables and disables current limit "A". 0: Disabled 1: Enabled.	0 or 1	1	Programming	112								
L8-19	04BFH	OH Frequency Reference Reduction Level Fref During OH	Sets the amount of frequency reference reduction when an Overheat Pre-alarm (OH) is detected.	0.0 to 100.0	20.0%	Programming	112								
Hunting Prev															
n1-01	0580H	Hunting Prevention Selection Hunt Prev Select	0: Disabled (Hunting prevention function disabled.) 1: Enabled (Hunting prevention function enabled.) If the motor vibrates while lightly loaded, hunting prevention may reduce the vibration. There is a loss of responsiveness if hunting prevention is enabled.	0 or 1	1	Programming	113								
n1-02	0581H	Hunting Prevention Gain Setting Hunt Prev Gain	Gain setting for the Hunting Prevention Function. If the motor vibrates while lightly loaded and n1-01=1, increase the gain by 0.1 until vibration ceases. If the motor stalls while n1-01=1 decrease the gain by 0.1 until the stalling ceases.	0.00 to 2.50	1.00	Programming	113								
High Slip															
n3-01	0588H	High-Slip Braking Deceleration Frequency Width HSB Decel Width	Sets how aggressively the Drive decreases the output frequency as it stops the motor. If overvoltage (OV) faults occur during HSB, this parameter may need to be increased. Note: Function Deactivated	1.0 to 20.0	5%	Programming	113								
n3-02	0589H	High-Slip Braking Current Limit HSB Current Ref	Sets the maximum current to be drawn during a HSB stop. Higher n3-02 settings will shorten motor stopping times but cause increased motor current, and therefore increased motor heating. Note: Function Deactivated	100.0 to 200.0	150%	Programming	113								
n3-03	058AH	High-Slip Braking Dwell Time at Stop HSB DwellTim@ Stp	Sets the amount of time the Drive will dwell at E1-09 (Minimum Frequency). If this time is set too low, the machine inertia can cause the motor to rotate slightly after the HSB stop is complete and Drive output is shut off. Note: Function Deactivated	0.00 to 10.0	1.0 sec	Programming	113								
n3-04	058BH	High-Slip Braking Overload Time HSB OL Time	Sets the time required for a HSB Overload Fault to occur when the Drive output frequency does not change for some reason during a HSB stop. Normally this does not need to be adjusted. Note: Function Deactivated	30.0 to 1200.0	40 sec	Programming	113								
Monitor Select															
o1-01 ◆	0500H	User Monitor Selection User Monitor Sel	Selects which monitor will be displayed upon power-up when o1-02 = 4.	6 to 94	6	Programming	114								
o1-02	0501H	User Monitor Selection After Power-Up Power-On Monitor	Selects which monitor will be displayed upon power-up. 1: Auto: Setpoint 2: Output Freq 3: Output Current 4: User Monitor (set by o1-01)	1 to 4	1**	Programming	114								
o1-05	0504H	LCD Brightness Adjustment LCD Contrast	<table border="1" style="margin-left: auto; margin-right: auto;"> <thead> <tr> <th>Set Value</th> <th>Description</th> </tr> </thead> <tbody> <tr> <td>5</td> <td>LCD display becomes dark</td> </tr> <tr> <td>3</td> <td>Standard setting</td> </tr> <tr> <td>1</td> <td>LCD display becomes light</td> </tr> </tbody> </table>	Set Value	Description	5	LCD display becomes dark	3	Standard setting	1	LCD display becomes light	0 to 5	3	Programming	115
Set Value	Description														
5	LCD display becomes dark														
3	Standard setting														
1	LCD display becomes light														
o1-06	0517H	User Monitor Selection Mode Monitor Mode Sel	Selects the "U1" monitors displayed on the 4th and 5th lines of the digital operator display. 0: 3 Mon Sequential (Displays the next 2 sequential U1 monitors.) 1: 3 Mon Selectable (Displays U1 monitors set by o1-07 and o1-08.)	0 or 1	1**	Programming	115								

◆ Denotes that parameter can be changed when the drive is running.

Parameter No.	Modbus Address	Parameter Name Digital Operator Display	Description	Setting Range	Factory Setting	Menu Location	Page No.
o1-07	0518H	Second Line User Monitor Selection 2nd Monitor Sel	Sets the “U1” monitor always displayed on the 4th line of the digital operator display. Effective only when o1-06 = 1.	1 to 94	2**	Programming	115
o1-08	0519H	Third Line User Monitor Selection 3rd Monitor Sel	Sets the “U1” monitor always displayed on the 5th line of the digital operator display. Effective only when o1-06 = 1.	1 to 94	91**	Programming	115
Key Selections							
o2-01	0505H	Local/Remote Key Function Selection Local/Remote Key	Has no function when HOA operator is connected. 0: Disabled 1: Enabled	0 or 1	1	Programming	116
o2-02	0506H	OFF Key Function During Auto Run Oper OFF Key	Determines if the off key on the digital operator will stop the Drive when Drive is operating from external terminals or serial communications. 0: Disabled 1: Enabled	0 or 1	1	Programming	116
o2-03	0507H	User Parameter Default Value User Defaults	Allows storing of current parameter values as a User Initialization Selection at parameter A1-03. 0: No Change (No user parameter set active). 1: Set Defaults (Saves current parameter settings as user initialization. A1-03 now allows selecting <1110> for user initialization. 2: Clear All (Clears the currently saved user initialization. A1-03 no longer allows selecting <1110>.	0 to 2	0	Programming	116
o2-04	0508H	Drive/kVA Selection Inverter Model #	Sets the kVA of the Drive. Enter the number based on Drive Model #. Use the □□□□ portion of the CIMR-P7□□□□-107 Model Number.	0 to FF	kVA Dependent	Programming	117
o2-05	0509H	Frequency Reference Setting Method Selection Operator M.O.P.	Determines if the Data/Enter key must be used to input a frequency reference from the digital operator. 0: Disabled - Data/Enter key must be pressed to enter a frequency reference. 1: Enabled: -Data/Enter key is not required. The frequency reference is adjusted by the up and down arrow keys on the digital operator without having to press the data/enter key.	0 or 1	0	Programming	118
o2-06	050AH	Operation Selection when Digital Operator is Disconnected Oper Detection	Determines if the Drive will stop when the digital operator is removed. 0: Disabled - The Drive will not stop when the digital operator is removed. 1: Enabled - The Drive will fault (OPR) and coast to stop when the operator is removed.	0 or 1	1	Programming	118
o2-07	050BH	Cumulative Operation Time Setting Elapsed Time Set	Sets the initial value of the elapsed operation timer.	0 to 65535	0 H	Programming	118
o2-08	050CH	Cumulative Operation Time Selection Elapsed Time Run	Sets how time is accumulated for the elapsed timer (o2-07). 0: Power-On Time (Time accumulates whenever Drive is powered). 1: Running Time (Time accumulates only when Drive is running)	0 or 1	1	Programming	118
o2-10	050EH	Cumulative Cooling Fan Operation Time Setting Fan ON Time Set	Sets the initial value of the heatsink fan operation time.	0 to 65535	0 H	Programming	119
o2-12	0510H	Fault Trace/Fault History Clear Function FLT Trace Init	Clears the fault memory contained in the U2 and U3 monitors. 0: Disabled (no effect). 1: Enabled - resets U2 and U3 monitors, and returns o2-12 to zero.	0 or 1	0	Programming	119
o2-14	0512H	kWh User Monitor (U1-29) Initialization kWh MonitorClear	Used to reset the kilowatt Hour monitor to zero 0: Disabled (no change). 1: Clear all - Resets U1-29 to zero and returns o2-14 to zero.	0 or 1	0	Programming	119
COPY Function							
o3-01	0515H	Copy Function Selection Copy Function Sel	This parameter controls the copying of parameters to and from the digital operator. 0: COPY SELECT (no function) 1: INV -> OP READ - All parameters are copied from the Drive to the digital operator. 2: OP -> INV WRITE - All parameters are copied from the digital operator into the Drive. 3: OP<->INV VERIFY - Parameter settings in the Drive are compared to those in the digital operator. Note: When using the copy function, the Drive model number and software number (U1-14) must match or an error will occur.	0 to 3	0	Programming	120

Parameter No.	Modbus Address	Parameter Name Digital Operator Display	Description	Setting Range	Factory Setting	Menu Location	Page No.
o3-02	0516H	Read Allowed Selection Read Allowable	Enables and disables all digital operator copy functions. 0: Disabled - No digital operator copy functions are allowed. 1: Enabled - Copying allowed	0 to 1	0	Programming	120
Pump Basic							
P1-01	0600H	Pump Mode Pump Mode	Select type of control operation. 0: Drive Only (Simplex) 1: Drive + 1 Pump 2: Drive + 2 Pumps	0 to 2	0	Programming	122
P1-02	0601H	System Units System Units	0: WC:InchOfWater 1: PSI:lb/SqrInch 2: GPM:Gallons/Min 3: F:DegFahrenheit 4: CFM:Cubic ft/Min 5: CMH:Cubic m/Hr 6: LPH:Liters/Hr 7: LPS:Liters/sec 8: Bar:Bar 9: Pa:Pascals 10: C:DegCelsius 11: Ft: Feet <0032> 12:%: Percent	0 to 12	1	Pump Quick Setup	124
P1-03	0602H	Feedback Device Scaling Fb Dev Scaling	Scaling of feedback device in user units (P1-02=1, e.g. 150PSI). Digits 1 through 4 set the maximum feedback number. Digit 5 determines the number of decimal places. Digit 5 = 0: Number format is XXXX Digit 5 = 1: Number format is XXX.X Digit 5 = 2: Number format is XX.XXX Digit 5 = 3: Number format is X.XXX Examples: 01000 = 1000 13000 = 300.0 25000 = 50.00 32000 = 2.000	1 to 36000 (system units P1-02)	00145	Pump Quick Setup	124
P1-04 ◆	0603H	Start Level Start Level	Drive starts when the feedback level drops below the start level for a time specified in P1-05. This level also specifies the wake up level when the drive is in Sleep Mode. Note: When PID operates in the reverse mode, the feedback value has to rise above the start level for the time programmed in P1-05 for the system to start. A value of 0 disables this function.	0.0 to 6000.0 (system units P1-02)	0.0 (system units P1-02)	Pump Quick Setup	125
P1-05 ◆	0604H	Start Level Delay Time S-Lvl Delay Time	Drive starts when the feedback level drops below the start level for a time specified in P1-05.	0 to 3600	0 sec	Pump Quick Setup	125
P1-06 ◆	0605H	Minimum Pump Frequency Min. Pump Freq.	Minimum drive frequency when operated in the auto mode. Programmed value will limit minimum PID output. Minimum value has to be programmed to a value smaller than P3-09 and P3-10 when Drive is operating in the multiplex mode (P1-01).	0.0 to 120.0 Hz	35.0 Hz	Pump Quick Setup	125
P1-07 ◆	0606H	Low Feedback Level Low FB Level	The Drive will display a “Low Feedback (LFB)” alarm when the feedback level falls below the programmed level. The alarm will turn off when the feedback level rises above the programmed Low Feedback Level plus the Hysteresis Level (P1-13). A value of 0 disables this function. This function is only active during running while operating in the auto mode.	0.0 to 6000.0 (system units P1-02)	0.0 (system units P1-02)	Pump Quick Setup	125
P1-08 ◆	0607H	Low Feedback Level Fault Delay Time Low Lvl FLT Time	The Drive will display a “Low Feedback/Water (LFB/LW)” alarm when the feedback level falls below the programmed level for a time specified in P1-08. The Drive will coast to a stop when a fault occurs. A value of 0 disables this function. This function is only active during running while operating in the auto mode.	0 to 3600 sec	5 sec	Pump Quick Setup	125
P1-09 ◆	0608H	High Feedback Level High FB Level	The Drive will display a “High Feedback Level (HFB)” alarm when the feedback level rises above the programmed level. The alarm will turn off when the feedback level falls below the programmed High Feedback Level minus the Hysteresis Level (P1-13). This function is active during running in the hand mode, auto mode, pre-charge and thrust-bearing mode.	0.0 to 6000.0 (system units P1-02)	155.0 (system units P1-02)	Pump Quick Setup	126
P1-10 ◆	0609H	High Feedback Level Fault Delay Time Hgh Lvl FLT Time	The Drive will initiate a “High Feedback Fault (HFB)” when the feedback level rises above the programmed level for a time specified in P1-10. The Drive will coast to a stop when a fault occurs. This function is active during running in all operation modes.	0 to 3600	2 sec	Pump Quick Setup	126

◆ Denotes that parameter can be changed when the drive is running.

Parameter No.	Modbus Address	Parameter Name Digital Operator Display	Description	Setting Range	Factory Setting	Menu Location	Page No.
P1-11 ◆ <0032>	0106H	Maximum SetPoint Difference Max Setpoint Diff	When the Drive is running and the difference between the setpoint and the feedback exceeds the level in P1-11 for the time specified in P1-12, the Drive will trip on a “Not Maintaining Setpoint (NMS)”. The Drive will coast to a stop when a fault occurs. A value of 0 disables this function. This function is only active during running while operating in auto mode.	0.0 to 6000.0 (system units P1-02)	0.0 (system units P1-02)	Pump Quick Setup	126
P1-12 ◆ <0032>	0107H	Not Maintaining Setpoint and Loss of Prime Time Setpoint-LOP Tim	Delay time before a Not Maintaining Setpoint or Loss of Prime Time fault occurs. Pump protection criteria specified in P1-11 or P1-14 must be met for the Drive to fault. The Drive will coast to a stop when a fault occurs. A value of 0 disables both Loss of Prime and Not Maintaining Setpoint faults.	0 to 3600	60 sec	Pump Quick Setup	127
P1-13 ◆	0108H	Hysteresis Level Hysteresis Level	Hysteresis Level used for low and high feedback alarm detection. See function P1-07 and P1-09.	0.0 to 100.0 (system units P1-02)	0.0 (system units P1-02)	Programming	127
P1-14 ◆	0109H	Prime Loss Level Prime Loss Level	Used to detect loss of prime in the pump. If output current drops below this level for the time specified in P1-12 and the output frequency is at fmax, a “Loss Of Prime” fault occurs. The Drive will coast to a stop when a fault occurs.	0.0 to 1000.0	0.0 A	Pump Quick Setup	127
P1-15 ◆	010AH	Low Water Input Low Water Input	Sets the type of control operation 0: Closed at Low Water, (Closed indicates low water condition) 1: Open at Low Water, (Open indicates low water condition) To use the low water function one of the digital inputs (H1-XX=85) needs to be programmed. The low water input can be used for a low water condition or in combination with the pre-charge function to indicate the reservoir is filled. The low water input fault is only active during running while operating in auto mode.	0 or 1	0	Programming	128
Pump Protection							
P2-01	060AH	Sleep Level Type Sleep Lvl Type	Sets the sleep type. 0: Output Frequency 1: Output Current 2: Feedback Note: Feedback depends on PID direction operation. Displays a “Sleep” Alarm when active.	0 to 2	0	Pump Quick Setup	129
P2-02 ◆	060BH	Sleep Level Sleep Level	Sleep activates when selected level (P2-01) reaches programmed sleep level for time specified in P2-03. The level type is determined by P2-01. A value of 0 disables this function. This function is only active during running while operating in auto mode. Display Units for Sleep Level P2-02 when P2-01 is programmed for the following: P2-01=0: >Display based on “Hz” P2-01=1: >Display based on “A” P2-01=2: >Display based on P1-02 Selection Note: When P2-01 is set for a value of 2, display units will be dependent on P1-02 setting.	0.0 to 6000.0	0.0	Pump Quick Setup	133
P2-03 ◆	060CH	Sleep Delay Time Sleep Delay Time	Delay time before Drive enters sleep mode when criteria is met as defined by parameter P2-02.	0 to 3600	10 sec	Pump Quick Setup	133
P2-04 ◆	060DH	Delta Sleep Feedback Drop Level D Fb Drop Level	When the Drive enters sleep mode, the software monitors the feedback to detect a flow-no flow condition. If the PID Error (setpoint minus feedback) exceeds the programmed level P2-04 within the programmed time (P2-05) and the output frequency is greater than the minimum frequency (P1-06), the sleep operation deactivates and the Drive returns to normal operation. A value of 0 disables this function.	0.0 to 6000.0 (system units P1-02)	0.0 (system units P1-02)	Programming	133
P2-05 ◆	060EH	Feedback detection drop time. FB Drop DetTime	Defines the time window in which the software monitors the feedback to detect a flow-no flow condition. Works in conjunction with parameter P2-04.	0 to 3600	10 sec	Programming	134
P2-06 ◆	060FH	Sleep Mode: Cycling Protection Cycle Protection	Maximum number of cycles allowed within the time specified in P2-07 before the Drive initiates a “Pump Cycle Fault (PCF)”. One Cycle is defined when the Drive transfers from normal operation in auto mode to sleep mode. A value of 0 disables this function.	0 to 10	0	Programming	134
P2-07 ◆	0610H	Sleep Mode: Maximum Cycling Protection Time Max. Cycle Time	Maximum time allowed between cycles. When no cycling occurs within the programmed time, the Drive will reset the internal cycle register. Works in conjunction with P2-06.	0 to 3600	300 sec	Programming	135
◆ Denotes that parameter can be changed when the Drive is running.							

Parameter No.	Modbus Address	Parameter Name Digital Operator Display	Description	Setting Range	Factory Setting	Menu Location	Page No.
P2-08	0611H	Over Cycling Mode Over Cycle Mode	Sets the Over Cycle Mode: 0: Disabled 1: Alarm 2: Pump Over Cycle Fault (POC) 3: Auto Compensation	0 to 3	0	Programming	135
P2-09	0612H	Setpoint compensation Setpoint Comp.	Allows for the software to automatically compensate the setpoint in case of excessive cycling.	0.0 to 6000.0 (system units P1-02)	0.0 (system units P1-02)	Programming	136
P2-10	0613H	Maximum Setpoint compensation Max. SP Comp.	Maximum allowable setpoint compensation for the over-cycling function.	0.0 to 6000.0 (system units P1-02)	0.0 (system units P1-02)	Pump Quick Setup	136
P2-11	010BH	No-Flow Activation Level NF Act. Level	When the motor RPM falls below the programmed level in P2-12, the no-flow detection will activate. A value of 0 disables this function.	0 to 24000	0 RPM	Programming	136
P2-12	010CH	No-Flow Detection Bandwidth NF Det.Bandwidth	Sets the motor RPM fluctuation bandwidth. No-flow activates when the motor RPM remains within the programmed bandwidth in P2-12 for a time specified in parameter P2-13.	0 to 1000	15 RPM	Programming	139
P2-13	010DH	No-Flow Detection Time NF Detect Time	No-flow activates when the motor RPM remains within the programmed bandwidth (P2-12) for a time specified in parameter P2-13.	0.0 to 1000.0	5.0 sec	Programming	139
P2-14	010EH	No-Flow Stabilization Time NF StabilizeTime	Time delay when setpoint returns to the original setting after being changed for no-flow detection.	0.0 to 1000.0	5.0 sec	Programming	139
P2-15	010FH	No-Flow Delta Feedback Level NF FB Level	No-flow feedback (PID-Error: setpoint minus feedback) level used to detect no-flow condition based on feedback value. Delta feedback (setpoint minus feedback) has to exceed the programmed level for the time programmed in P2-17 to detect a no-flow condition.	0.0 to 6000.0 (system units P1-02)	1.0 (system units P1-02)	Programming	139
P2-16	011FH	No-Flow Setpoint Compensation NF SP Comp.	Setpoint compensation used in the no-flow detection function.	0.0 to 6000.0 (system units P1-02)	1.5 (system units P1-02)	Programming	140
P2-17	0120H	No-Flow Feedback Delay Time NF FB.Delay Time	Delay timer used in combination with the no-flow feedback (PID-Error: setpoint minus feedback) level (P2-15) used to detect the no-flow condition based on the feedback value. Delta feedback (Setpoint minus feedback) has to exceed the programmed level (P2-15) for the time programmed to detect a no-flow condition.	0.0 to 1000.0	2.0 sec	Programming	140
P2-18	0121H	No-Flow Motor RPM Sample Time NF RPM Sample Tm	No-flow detection motor RPM sample rate.	0.1 to 1000.0	2.0 sec	Programming	140
P2-19	0122H	No-Flow Feedback Detection Direction NF FB Det.Direct	Direction of feedback detection upon return of no-flow detection. 0: Outside Bandwidth (P2-15) 1: Inside Bandwidth (P2-15)	0 or 1	0	Programming	140
P2-20 ◆	0123H	Alternative Sleep Activate Level SLP Act. Level	When P2-01 Sleep Level Type is set for 0 (Output Frequency), the sleep function becomes active when the output frequency is greater or equal to the level in P2-20. When programmed to 0, the sleep function will become active above the P2-02 Sleep Level. A value of 0 disables this function.	0.0 to 120.0	0.0 Hz	Programming	141
◆ Denotes that parameter can be changed when the Drive is running.							
Pump Multiplex							
P3-01	0614H	Lead-Lag Control Lead-Lag Control	Selects lead-lag detection operation. 0: Output Frequency (Output Frequency). 0: Uses P3-02, P3-04, P3-06, P3-09, P3-10. 1: Feedback (Feedback Level). 1: Uses P3-03,P3-04,P3-05,P3-06. 2: Feedback + Fout (Feedback Level and Output Frequency). 2: Uses P3-02,P3-03,P3-05,P3-06,P3-07, P3-08,P3-10. Works in conjunction with parameters P2-11 to P2-19.	0 to 2	0	Programming	143

Parameter No.	Modbus Address	Parameter Name Digital Operator Display	Description	Setting Range	Factory Setting	Menu Location	Page No.
P3-02 ◆	0615H	Drive Multi/Maximum Level Max-Multi Level	<p>Sets the maximum level used for multiplex pumping operation. Parameter is active when P3-01 = 0 or P3-01 = 2 is selected.</p> <p>P3-01=0: When the output frequency rises above the level programmed in P3-02 for a time specified in P3-04, the next available pump will be added to the system by means of a multi-function digital output closure (H2-XX = 40, 41).</p> <p>P3-01=1: Not Used.</p> <p>P3-01=2: When the output frequency rises above level programmed in P3-02 and the delta feedback (setpoint minus feedback) has exceeded the level programmed in P3-03 for a time specified in P3-04, the next available pump will be added to the system by means of a multi-function digital output closure (H2-XX = 40, 41).</p>	0.0 to 120.00	59.0 Hz	Programming	149
P3-03 ◆	0616H	Add Pump Delta Level Add Pump D-Lvl	<p>Sets the level used for multiplex pumping operation. The parameter is active when P3-01 = 1 or P3-01 = 2 is selected.</p> <p>P3-01=0: Not Used.</p> <p>P3-01=1: When the delta feedback (setpoint minus feedback) has exceeded the level programmed in P3-03 for a time specified in P3-04, the next available pump will be added to the system by means of a multi-function digital output closure. (H2-XX = 40, 41).</p> <p>P3-01=2: When the output frequency rises above level programmed in P3-02 and the delta feedback (Setpoint minus feedback) has exceeded the level programmed in P3-03 for a time specified in P3-04, the next available pump will be added to the system by means of a multi-function digital output closure. (H2-XX = 40, 41).</p> <p>Note: Do not program this level too close to the system setpoint or excessive cycling of the pump system may occur.</p>	0.0 to 6000.0 (system units P1-02)	0.0 (system units P1-02)	Programming	150
P3-04 ◆	0617H	Add Pump Delay Time Add Pump Dly Tm	<p>Sets the delay time before a pump is added to the system. Works in conjunction with parameters P3-02, P3-03, and P2-11 to P2-19.</p>	0 to 3600	2 sec	Programming	150
P3-05 ◆	0618H	Shutdown Pump Delta Level Shdn Pump D-Lvl	<p>Sets the level used for multiplex pumping operation. Parameter is active when P3-01 = 1 or P3-01 = 2 is selected.</p> <p>P3-01=0: Not Used.</p> <p>P3-01=1: When the delta feedback (feedback minus setpoint) has exceeded the level programmed in P3-05 for a time specified in P3-06, the last pump that was brought online will be shutdown by means of a multi-function digital output opening. (H2-XX = 40, 41).</p> <p>P3-01=2: When the output frequency drops below level programmed in P3-09 or P3-10 (depends on last pump running) and the delta feedback (feedback minus setpoint) has exceeded the level programmed in P3-05 for a time specified in P3-06, the last pump that was brought online will be shutdown by means of a multi-function digital output opening. (H2-XX = 40, 41).</p> <p>Note: Do not program this level too close to the system setpoint or excessive cycling of the pump system may occur.</p>	0.0 to 6000.0 (system units P1-02)	0.0 (system units P1-02)	Programming	150
P3-06 ◆	0619H	Shutdown Pump Delay Time Shdn Pump Dly Tm	<p>Sets the delay time before one of the additional across the line pumps is shutdown. Works in conjunction with parameters P3-02 and P3-03.</p>	0 to 3600	5 sec	Programming	151
P3-07 ◆	061AH	Multi Pump Setpoint Increase MP Setpoint Inc.	<p>Sets the amount the Drive's setpoint will decrease for each time a new pump is brought offline.</p> <p>Pump 1: Setpoint. Pump 1+2: Setpoint + P3-07. Pump 1+2+3: Setpoint + (2 x P3-07).</p>	0.0 to 6000.0 (system units P1-02)	0.0 (system units P1-02)	Programming	151
P3-08 ◆	061BH	Multi Pump Setpoint Decrease MP Setpoint Dec.	<p>Sets the amount the Drive's setpoint will increase for each time a new pump is brought online.</p> <p>Pump 1: Setpoint. Pump 1+2: Setpoint - P3-08. Pump 1+2+3: Setpoint - (2 x P3-08).</p>	0.0 to 6000.0 (system units P1-02)	0.0 (system units P1-02)	Programming	152

◆ Denotes that parameter can be changed when the Drive is running.

Parameter No.	Modbus Address	Parameter Name Digital Operator Display	Description	Setting Range	Factory Setting	Menu Location	Page No.
P3-09 ◆	061CH	Pump 2 Frequency Shutdown Level P2 Freq. Shd Lvl	<p>Sets the level used for multiplex pumping operation. Parameter is active when P3-01 = 0 or P3-01 = 2 is selected.</p> <p>P3-01=0: When the output frequency falls below the level programmed in P3-09 for a time specified in P3-06 and a total of 2 pumps are running, the last pump (Pump 2) that was brought online will be shutdown by means of a multi-function digital output opening (H2-XX = 40, 41).</p> <p>P3-01=1: Not Used.</p> <p>P3-01=2: When the output frequency falls below the level programmed in P3-09 and a total of 2 pumps are running and the delta feedback (feedback minus setpoint) has exceeded the level programmed in P3-05 for a time specified in P3-06, the last pump (Pump 2) that was brought online will be shutdown by means of a multi-function digital output opening (H2-XX = 40, 41).</p>	0.0 to 120.0	35.0 Hz	Programming	153
P3-10 ◆	061DH	Pump 3 Frequency Shutdown Level P3 Freq. Shd Lvl	<p>Sets the level used for multiplex pumping operation. Parameter is active when P3-01 = 0 or P3-01 = 2 is selected.</p> <p>PE-01=0: When the output frequency falls below the level programmed in P3-10 for a time specified in P3-06 and a total of 3 pumps are running, the last pump (Pump 3) that was brought online will be shutdown by means of a multi-function digital output opening (H2-XX = 40, 41).</p> <p>P3-01=1: Not Used.</p> <p>P3-01=2: When the output frequency falls below the level programmed in P3-10 and a total of 3 pumps are running and the delta feedback (feedback minus setpoint) has exceeded the level programmed in P3-05 for a time specified in P3-06, the last pump (Pump 3) that was brought online will be shutdown by means of a multi-function digital output opening (H2-XX = 40, 41).</p>	0.0 to 120.00	35.0 Hz	Programming	153
P3-11 ◆	0110H	Multiplex Stabilization Time M-Stabilize Time	<p>Sets the time used to stabilize system when a pump is added (brought online) or shutdown during multiplex operation. When a pump is added, the stabilize timer temporarily disables the lead/lag functionality for the programmed time to prevent pump cycling.</p> <p>Note: This function only active in the multiplex mode when P1-01 is greater than 0. During the stabilization time, the pump protection and lead-lag control is suspended.</p>	0 to 3600	2 sec	Programming	154
P3-12 ◆	0111H	Delta Setpoint Feedback Acc/Dec Changeover SP ACC/DEC Hyst.	<p>Sets the level when the acceleration and deceleration times change over to the values programmed in C1-05 and C1-06 respectively. This function will activate when the difference between the delta setpoint and feedback are within the level programmed in P3-12. This function is used to improve the pump regulation. A value of 0 disables this function.</p>	0.0 to 6000.0 (system units P1-02)	0.0 (system units P1-02)	Programming	155
P3-13 ◆	0112H	Friction compensation start Frequency Fric. Comp. Lvl	<p>Sets the level when the setpoint will be adjusted to compensate for the friction losses. This function will activate when the output frequency rises above the level programmed in P3-13. The maximum compensation at maximum output frequency (E1-04) is specified by maximum setpoint frequency (P2-10).</p> <p>Note: This function is only active in simplex mode when P1-01 = 0.</p>	0.0 to 120.0	0.0 Hz	Programming	156
P3-14 ◆	0113H	Maximum Friction Increase at Maximum Frequency Friction Inc.	<p>Sets the maximum setpoint friction compensation at maximum output frequency (E1-04). This function is a linear calculation with P3-13 as its starting frequency. Example: P3-13 = 30.0 Hz, P3-14 = 10.0 PSI, output frequency = 45.0 Hz and maximum frequency = 60.0 Hz Setpoint Increase = (45-30 Hz) x 10 PSI / (60 Hz – 30 Hz) ≥ 5.0PSI</p> <p>Note: This function is only active in simplex mode when P1-01 = 0.</p>	0.0 to 6000.0 (system units P1-02)	0.0 (system units P1-02)	Programming	156

◆ Denotes that parameter can be changed when the Drive is running.

Parameter No.	Modbus Address	Parameter Name Digital Operator Display	Description	Setting Range	Factory Setting	Menu Location	Page No.
Pump Advanced							
P4-01 ◆	0115H	Pre-Charge Level Pre-Charge Level	Sets the level when the drive will run at the pre-charge frequency (P4-02). The Drive will stop when one of the following conditions occurs: Feedback signal rises above P4-01 level, pre-charge timer P4-03 expires, or low water digital input is deactivated (H1-XX = 85). The pre-charge function can only be activated while in a stop condition. The function is enabled by setting P4-03 to a value greater than 0. When the function is activated, the drive's operator display indicates a "Pre-charge" alarm. Note: This function is only active in the stopped mode. Thrust Mode: The pre-charge level is used when the thrust mode is active for the feedback check. The thrust mode is deactivated when the feedback exceeds the programmed level in P4-01. A value of 0 disables the thrust mode feedback check function.	0.0 to 6000.0 (system units P1-02)	0.0 (system units P1-02)	Pump Quick Setup	158
P4-02 ◆	0116H	Pre-Charge Frequency Pre-Charge Freq.	Sets the frequency reference used when the pre-charge function is active.	0.0 to 120.0	0.0 Hz	Pump Quick Setup	163
P4-03 ◆	0117H	Pre-Charge Time Pre-Charge Time	Sets the maximum allowed pre-charge time. A value of 0 disables this function.	0.0 to 3600.0	0.0 min	Pump Quick Setup	164
P4-04 ◆	0118H	Thrust Bearing Acceleration Time Thrust Acc. Time	Sets the thrust bearing acceleration time. When enabled (P4-05>0), the Drive output frequency will ramp up to the specified thrust bearing frequency reference in P4-05 using an acceleration time as specified in P4-04. The PI mode is automatically disabled. Once the output frequency reaches the programmed thrust bearing frequency, the Drive automatically switches to PI control and the original acceleration time (C1-01), and will continue in the normal operation (auto) mode, unless Pre-Charge is enabled, in which case Pre-Charge mode occurs. This function active in the Hand Mode and Auto Mode. Note: In Auto Mode , the Minimum Pump Frequency will become the thrust bearing frequency if smaller than the thrust bearing frequency in P4-05. In Hand Mode , the minimum frequency is P4-05 when the thrust mode is enabled. The Pre-Charge level is not active in the hand mode.	0.0 to 6000.0	1.0 sec	Pump Quick Setup	164
P4-05 ◆	0119H	Thrust Bearing Frequency Thrust Freq.	Sets the frequency reference used when the thrust bearing function is active. A value of 0 disables this function.	0.0 to 120.0	0.0 Hz	Pump Quick Setup	165
P4-06 ◆ <0032>	011AH	Thrust Bearing Deceleration Time Thrust Dec Time.	This deceleration time will be used to bring the Drive from Thrust Frequency (P4-05) to stop when Thrust Mode is active. Any time the Run Command is removed while the drive is operating in the Thrust Mode above the Thrust Frequency, this deceleration time will be used once the frequency reference is at or below the Thrust Frequency. Note: In Auto Mode , the Minimum Pump Frequency (P1-06) will become the thrust bearing frequency if smaller than the thrust bearing frequency in P4-05. In Hand Mode , the minimum frequency is P4-05 when the thrust mode is enabled. The Pre-Charge level is not active in the hand mode.	0.0 to 6000.0	1.0 sec	Pump Quick Setup	165
P4-07 <0032>	011BH	Feedback Fault Auto Restart Enable Fdback Flt Rstrt	Setting to enable / disable Auto Restart for the following iQpump transducer / feedback faults (N = disable / Y = enable): LL: Low Level Feedback (P1-07) HL: High Level Feedback (P1-09) TL: Transducer Loss (b5-12) 0: TL = N HL = N LL = N 1: TL = N HL = N LL = Y 2: TL = N HL = Y LL = N 3: TL = N HL = Y LL = Y 4: TL = Y HL = N LL = N 5: TL = Y HL = N LL = Y 6: TL = Y HL = Y LL = N 7: TL = Y HL = Y LL = Y Note: Parameter L5-01 needs to be set to "1" and program L5-03 needs to be set to the applicable time.	0 to 7	0	Pump Quick Setup	165

◆ Denotes that parameter can be changed when the Drive is running.

Parameter No.	Modbus Address	Parameter Name Digital Operator Display	Description	Setting Range	Factory Setting	Menu Location	Page No.
P4-08 <0032>	011CH	Protection Fault Auto Restart Enable Prot Flt Restr	Setting to enable / disable Auto Restart for the following iQpump protection faults (N = disable / Y = enable): SP: Not Maintaining SetPoint (P1-11) LOP: Loss of Prime (P1-12) POC: Pump Over Cycling (P2-08)) 0: POC = N LOP = N SP = N 1: POC = N LOP = N SP = Y 2: POC = N LOP = Y SP = N 3: POC = N LOP = Y SP = Y 4: POC = Y LOP = N SP = N 5: POC = Y LOP = N SP = Y 6: POC = Y LOP = Y SP = N 7: POC = Y LOP = Y SP = Y Note: Parameter L5-01 needs to be set to “1” and program L5-03 needs to be set to the applicable time.	0 to 7	0	Pump Quick Setup	165
P4-09 <0032>	011DH	Loss of Prime Maximum Restart Time After Fault LOP Max Rstrt T	If the restart fails (or is not attempted due to a continuing fault condition) the Drive waits this many minutes before attempting another restart. Note: This parameter will take the place of L5-03 during a Loss of Prime Fault restart attempt.	0.2 to 6000.0	0.2 min	Pump Quick Setup	165
P4-10 ◆	011EH	Auto Mode Operator Run Power Down Storage. AMO PwDn-Storage	Stores the run status in the Auto mode when operating from digital operator (b1-02=0). 0: Disabled. 1: Enabled. <div style="text-align: center;"> WARNING</div> When the drive is powered down while running, then upon power-up it will automatically initiate an internal run command.	0 or 1	0	Pump Quick Setup	167
Hand Mode							
P5-01 ◆	0124H	Hand Mode Reference Source Hand Mode Ref.	Sets the hand mode reference source. 0: Analog Input A1 (0-10 V). 1: Hand reference (P5-02).	0 or 1	1	Pump Quick Setup	168
P5-02 ◆	0125H	Hand Reference Hand Reference	Sets the frequency reference used when the hand mode is active and P5-01 is programmed to 1.	0.0 to 120.0	0.0 Hz	Pump Quick Setup	169
P5-03 <0032>	0114H	HAND/AUTO During Run Selection HAND/AUTO @Run	Selects if the Drive will permit switching between HAND and AUTO modes while running. 0: Disabled. 1: Enabled. Switching from HAND to AUTO is not permitted when the Drive output frequency is less than the PID minimum speed. Switching from AUTO to HAND is not permitted when the Drive is running in the multiplex mode with auxiliary drives enabled.	0 to 1	0	Programming	169
P5-04 <0032>	0513H	Hand Key Function Selection Oper HAND Key	Enables or disables the “HAND” key on the digital operator. 0: Disabled. 1: Enabled.	0 to 1	1	Programming	169
Auto-Tuning							
T1-02	0702H	Motor Rated Power Mtr Rated Power	Sets the motor rated power in kW. Note: T1-02 should be left at the default value (last 3 digits of the Drive model number).	0.00 to 650.0	kVA Dependent	Auto-Tuning	172
T1-04	0704H	Motor Rated Current Rated Current	Sets the motor rated current. (Used only during an auto-tune.)	kVA Dependent	kVA Dependent	Auto-Tuning	172
◆ Denotes that parameter can be changed when the Drive is running.							

Monitor List

Table 2 Monitor List

Parameter No.	Modbus Address	Parameter Name Digital Operator Display	Description
			Monitor
U1-01	0040H	Auto Setpoint Reference Auto: Setpoint	Auto Setpoint Reference (speed command) monitor when in auto mode, frequency reference (speed command) setting location when in hand mode. Units changeable via P1-02.
U1-02	0041H	Output Frequency Output Freq	Output frequency monitor in Hz.
U1-03	0042H	Output Current Output Current	Output current monitor.
U1-06	0045H	Output Voltage Output Voltage	Displays Drive output voltage.
U1-07	0046H	DC Bus Voltage DC Bus Voltage	Displays DC bus voltage.
U1-08	0047H	Output Power Output kWatts	Displays Drive output power.
U1-10	0049H	Input Terminal Status Input Term Sts	Displays Drive input terminal status.
U1-11	004AH	Output Terminal Status Output Term Sts	Output terminal ON/OFF check.
U1-12	004BH	Drive Operation Status Int Ctl Sts 1	
U1-13	004CH	Cumulative Operation Time Elapsed Time	Displays total operating or power-on time of the Drive.
U1-14	004DH	Software Number FLASH ID	Displays Drive's software number.
U1-15	004EH	Terminal A1 Input Voltage Term A1 Level	Displays the input voltage on Terminal A1, as a percentage of 10 Vdc.

Parameter No.	Modbus Address	Parameter Name Digital Operator Display	Description
			Monitor
U1-16	004FH	Terminal A2 Input Voltage Term A2 level	Displays the input current (or voltage) on Terminal A2, as a percentage of 20 mA (or 10 Vdc).
U1-18	0051H	Motor Secondary Current (Iq) Mot SEC Current	Displays the amount of current being used by the motor to produce torque (Iq).
U1-20	0053H	Output Frequency After Soft Start SFS Output	Displays the frequency reference (speed command) after the accel and decel ramps.
U1-24	0057H	PI Feedback Value PI Feedback	Displays the feedback signal when PI control is used.
U1-28	005BH	CPU Number CPU ID	Displays control board hardware revision.
U1-29	005CH	kWh kWh Lo 4 Digits	Displays the accumulated kWh.
U1-30	005DH	MWh kWh Hi 5 Digits	Displays the accumulated MWh.
U1-34	0061H	First Parameter Causing an OPE OPE Detected	Displays the parameter number causing an "OPE" fault.
U1-36	0063H	PI Input PI Input	Displays the "error" in the PI regulator. (U1-36 = PI Setpoint - PI Feedback).
U1-37	0064H	PI Output PI Output	Displays the output of the PI as a percentage of maximum frequency (E1-04).
U1-38	0065H	PI Setpoint PI Setpoint	Displays the setpoint of the PI regulator (U1-38 = PI reference + PI bias).
U1-39	0066H	Memobus Communication Error Code Transmit Err	
U1-40	0067H	Heatsink Cooling Fan Operation Time FAN Elapsed Time	Displays total operating time of the heatsink cooling fan.
U1-90	0720H	Pump Setpoint Pump Setpoint	Displays drive setpoint. Resolution 0.1 Note: Does not include setpoint compensation (U1-93).
U1-91	0721H	Pump Feedback Pump Feedback	Displays scaled feedback. Resolution 0.1
U1-92	0722H	Pump Status Pump Status	Display pump running status.

Parameter No.	Modbus Address	Parameter Name Digital Operator Display	Description
			Monitor
U1-93	723H	Total Setpoint Compensation Total SP Comp.	Displays total absolute setpoint compensation. resolution 1
U1-94	724H	Motor Speed Motor Speed	Displays motor speed (RPM). Used for no-flow detection (P2 Group).

Fault Trace List

Table 3 Fault Trace List

Parameter No.	Modbus Address	Fault Trace
U2-01	0080H	Current Fault Current Fault
U2-02	0081H	Previous Fault Last Fault
U2-03	0082H	Frequency Reference at Most Recent Fault Frequency Ref
U2-04	0083H	Output Frequency at Most Recent Fault Output Freq
U2-05	0084H	Output Current at Most Recent Fault Output Current
U2-07	0086H	Output Voltage at Most Recent Fault Output Voltage
U2-08	0087H	DC Bus Voltage at Most Recent Fault DC Bus Voltage
U2-09	0088H	Output Power at Most Recent Fault Output kWatts
U2-11	008AH	Input Terminal Status at Most Recent Fault. The format is the same as for U1-10. Input Term Sts
U2-12	008BH	Output Terminal Status at Most Recent Fault. The format is the same as for U1-11. Output Term Sts
U2-13	008CH	Drive Operation Status at Most Recent Fault. The format is the same as for U1-12. Inverter Status
U2-14	008DH	Cumulative Operation Time at Most Recent Fault Elapsed time

Note: Fault trace is not executed at CPF00, CPF01, CPF03, UVI and UV2.

Fault History List

Table 4 Fault History List

Parameter No.	Modbus Address	Fault History
U3-01	0090H	Most Recent Fault Last Fault
U3-02	0091H	2nd Most Recent Fault Fault Message 2
U3-03	0092H	3rd Most Recent Fault Fault Message 3
U3-04	0093H	4th Most Recent Fault Fault Message 4
U3-05	0094H	Cumulative Operation Time at Most Recent Fault Elapsed Time 1
U3-06	0095H	Cumulative Operation Time at 2nd Most Recent Fault Elapsed Time 2
U3-07	009BH	Cumulative Operation Time at 3rd Most Recent Fault Elapsed Time 3
U3-08	0097H	Cumulative Operation Time at 4th Most Recent Fault Elapsed Time 4
U3-09	0804H	5th Most Recent Fault Fault Message 5
U3-10	0805H	6th Most Recent Fault Fault Message 6
U3-11	0806H	7th Most Recent Fault Fault Message 7
U3-12	0807H	8th Most Recent Fault Fault Message 8
U3-13	0808H	9th Most Recent Fault Fault Message 9
U3-14	0809H	10th Most Recent Fault Fault Message 10
U3-15	080EH	Cumulative Operation Time at 5th Most Recent Fault Elapsed Time 5
U3-16	080FH	Cumulative Operation Time at 6th Most Recent Fault Elapsed Time 6
U3-17	0810H	Cumulative Operation Time at 7th Most Recent Fault Elapsed Time 7
U3-18	0811H	Cumulative Operation Time at 8th Most Recent Fault Elapsed Time 8
U3-19	0812H	Cumulative Operation Time at 9th Most Recent Fault Elapsed Time 9
U3-20	0813H	Cumulative Operation Time at 10th Most Recent Fault Elapsed Time 10

Note: Faults such as CPF00, CPF01, CPF02, CPF03, UV1, and UV02 are not stored in fault history.

Table 5 Decimal to Hex Conversion

Decimal	Hex	Decimal	Hex
1	1	51	33
2	2	52	34
3	3	53	35
4	4	54	36
5	5	55	37
6	6	56	38
7	7	57	39
8	8	58	3A
9	9	59	3B
10	A	60	3C
11	B	61	3D
12	C	62	3E
13	D	63	3F
14	E	64	40
15	F	65	41
16	10	66	42
17	11	67	43
18	12	68	44
19	13	69	45
20	14	70	46
21	15	71	47
22	16	72	48
23	17	73	49
24	18	74	4A
25	19	75	4B
26	1A	76	4C
27	1B	77	4D
28	1C	78	4E
29	1D	79	4F
30	1E	80	50
31	1F	81	51
32	20	82	52
33	21	83	53
34	22	84	54
35	23	85	55
36	24	86	56
37	25	87	57
38	26	88	58
39	27	89	59
40	28	90	5A
41	29	91	5B
42	2A	92	5C
43	2B	93	5D
44	2C	94	5E
45	2D	95	5F
46	2E	96	60
47	2F	97	61
48	30	98	62
49	31	99	63
50	32	100	64

THIS PAGE INTENTIONALLY LEFT BLANK.



Appendix: B

Capacity Related Parameters

This appendix lists the parameters affected by the Drive Capacity setting of o2-04.

B.1 Drive Capacity	198
B.2 Parameters Affected by o2-04	199
B.3 Capacity Related Parameter Values	200

B.1 Drive Capacity

Parameter o2-04 sets the iQpump drive capacity according to the model number. Parameter o2-04 will need to be adjusted when replacing a control board.

If a Control PCB is changed, the first time the iQpump drive is powered up, parameter o2-04 must be set to the appropriate value listed in *Table B.1* for the iQpump drive model number. After properly setting parameter o2-04, a 2-wire or 3-wire initialization must be performed by setting parameter A1-03 = 2220 or A1-03 = 3330, respectively. This will automatically program the values of all other parameters listed in *Table B.2* to the factory settings for that particular iQpump drive rating.

Table B.1 Drive Capacity Selection

Voltage	Model Number (CIMR-P7U□-107)	o2-04 Setting	Nominal Hp
208-240 VAC	CIMR-P7U20P4	0	0.5/0.75
	CIMR-P7U20P7	1	1
	CIMR-P7U21P5	2	1.5/2
	CIMR-P7U22P2	3	3
	CIMR-P7U23P7	4	5
	CIMR-P7U25P5	5	7.5
	CIMR-P7U27P5	6	10
	CIMR-P7U2011	7	15
	CIMR-P7U2015	8	20
	CIMR-P7U2018	9	25
	CIMR-P7U2022	A	30
	CIMR-P7U2030	B	40
208-230 VAC	CIMR-P7U2037	C	50
	CIMR-P7U2045	D	60
	CIMR-P7U2055	E	75
	CIMR-P7U2075	F	75/100
	CIMR-P7U2090	10	125
	CIMR-P7U2110	11	150
480 VAC	CIMR-P7U40P4	20	0.5/0.75
	CIMR-P7U40P7	21	1
	CIMR-P7U41P5	22	1.5/2
	CIMR-P7U42P2	23	3
	CIMR-P7U43P7	24	5
	CIMR-P7U45P5	26	7.5
	CIMR-P7U47P5	27	10
	CIMR-P7U49P0	3C	15
	CIMR-P7U4011	28	20
	CIMR-P7U4015	29	25
	CIMR-P7U4018	2A	30
	CIMR-P7U4024	3D	40
	CIMR-P7U4030	2C	50
	CIMR-P7U4037	2D	60
	CIMR-P7U4045	2E	75
	CIMR-P7U4055	2F	100
	CIMR-P7U4075	30	125
	CIMR-P7U4090	31	150
	CIMR-P7U4110	32	200
	CIMR-P7U4160	34	250
CIMR-P7U4185	35	300/350	
CIMR-P7U4220	36	400/450	
CIMR-P7U4300	37	500+	

B.2 Parameters Affected by o2-04

The factory setting of the following parameters may change when the iQpump drive capacity is changed.

Table B.2 Parameters Affected by o2-04

Parameter Number	Parameter Name Digital Operator Display
b8-04	Energy Saving Coefficient Value Energy Save COEF
C6-02	Carrier Frequency Selection CarrierFreq Sel
E2-01	Motor Rated Current Motor Rated FLA
E2-03	Motor No Load Current No-Load Current
E2-05	Motor Line-to-Line Resistance Term Resistance
L2-02	Momentary Power Loss Ride-thru Time PwrL Ridethru t
L2-03	Momentary Power Loss Minimum Base Block Time PwrL Baseblock t
L2-04	Momentary Power Loss Voltage Recovery Ramp Time PwrL V/F Ramp t
L8-02	Overheat Pre-Alarm Level OH Pre-Alarm Lvl
L8-06	Input Phase Loss Detection Level Ph Loss In Lvl
o2-04	Drive/kVA Selection Inverter Model #

B.3 Capacity Related Parameter Values

The following tables detail the factory default settings for the parameters that are affected by the setting of parameter o2-04.

Table B.3 208/240 VAC iQpump Drives

Drive Model CIMR-P7U□-107	Nominal Hp	Factory Default for b8-04	Factory Default for C6-02 <0032>	Factory Default for E2-01	Factory Default for E2-03	Factory Default for E2-05	Factory Default for L2-02	Factory Default for L2-03	Factory Default for L2-04	Factory Default for L8-02	Factory Default for L8-06
20P4	0.5/0.75	288.2	8 kHz	1.9	1.2	9.842	0.1	0.1	0.3	95° C	5
20P7	2	223.7	8 kHz	3.3	1.8	5.156	0.1	0.2	0.3	95° C	7.5
21P5	1.5/2	169.4	8 kHz	6.2	2.8	1.997	0.2	0.3	0.3	95° C	10
22P2	3	156.8	8 kHz	8.5	3.0	1.601	0.3	0.4	0.3	100° C	12
23P7	5	122.9	8 kHz	14.0	4.5	0.771	0.5	0.5	0.3	95° C	12
25P5	7.5	94.75	8 kHz	19.6	5.1	0.399	1.0	0.6	0.3	95° C	10
27P5	10	72.69	8 kHz	26.6	8.0	0.288	1.0	0.7	0.3	95° C	17
2011	15	70.44	8 kHz	39.7	11.2	0.230	1.0	0.8	0.3	95° C	21
2015	20	63.13	8 kHz	53.0	15.2	0.138	2.0	0.9	0.3	90° C	17
2018	25	57.87	8 kHz	65.8	15.7	0.101	2.0	1.0	0.6	100° C	15
2022	30	51.79	8 kHz	77.2	18.5	0.079	2.0	1.0	0.6	90° C	24
2030	40	46.27	8 kHz	105.0	21.9	0.064	2.0	1.1	0.6	90° C	20
2037	50	38.16	5 kHz	131.0	38.2	0.039	2.0	1.1	0.6	95° C	18
2045	60	35.78	5 kHz	160.0	44.0	0.030	2.0	1.2	0.6	100° C	20
2055	75	31.35	8 kHz	190.0	45.6	0.022	2.0	1.2	0.1	105° C	17
2075	75/100	23.10	2 kHz	260.0	72.0	0.023	2.0	1.3	0.1	110° C	16
2090	125	20.65	2 kHz	260.0	72.0	0.023	2.0	1.5	0.1	100° C	18
2110	150	18.12	2 kHz	260.0	72.0	0.023	2.0	1.7	0.1	95° C	20

Note: b8-04 = Energy Savings Coefficient
 C6-02 = Carrier Frequency
 E2-01 = Motor Rated Current
 E2-03 = Motor No-Load Current
 E2-05 = Motor Line-to-Line Resistance
 L2-02 = Momentary Power Loss Ride-Thru Time
 L2-03 = Momentary Power Loss Minimum Base Block Time
 L2-04 = Momentary Power Loss Voltage Recovery Ramp Time
 L8-02 = Overheat Pre-Alarm Level
 L8-06 = Input Phase Loss Detection Level

Table B.4 480 VAC iQpump Drives

Drive Model CIMR-P7U□-107	Nominal Hp	Factory Default for b8-04	Factory Default for C6-02 <0032>	Factory Default for E2-01	Factory Default for E2-03	Factory Default for E2-05	Factory Default for L2-02	Factory Default for L2-03	Factory Default for L2-04	Factory Default for L8-02	Factory Default for L8-06
40P4	0.5/0.75	576.40	8 kHz	1.0	0.6	38.198	0.1	0.1	0.3	95°C	5
40P7	1	447.40	8 kHz	1.6	0.8	22.459	0.1	0.2	0.3	95°C	7.5
41P5	1.5/2	338.80	8 kHz	3.1	1.4	10.100	0.2	0.3	0.3	95°C	10
42P2	3	313.60	8 kHz	4.2	1.5	6.495	0.3	0.4	0.3	90 °C	10
43P7	5	245.80	8 kHz	7.0	2.3	3.333	0.5	0.5	0.3	95°C	12
45P5	7.5	189.50	8 kHz	13.3	2.6	1.595	1.0	0.6	0.3	95°C	10
47P5	10	145.38	8 kHz	19.9	4.0	1.152	1.0	0.7	0.3	90°C	20
49P0	15	145.46	8 kHz	21.0	5.6	0.922	2.0	0.8	0.3	95°C	23
4011	20	140.88	8 kHz	26.5	5.6	0.922	2.0	0.8	0.3	95°C	23
4015	25	126.26	8 kHz	32.9	7.6	0.550	2.0	0.9	0.3	95°C	17
4018	30	115.74	8 kHz	52.3	7.8	0.403	2.0	1.0	0.6	98°C	17
4024	40	89.08	8 kHz	52.0	8.6	0.269	2.0	1.1	0.6	85°C	20
4030	50	92.54	8 kHz	65.6	10.9	0.269	2.0	1.1	0.6	85°C	20
4037	60	76.32	8 kHz	79.7	19.1	0.155	2.0	1.1	0.6	85°C	20
4045	75	71.56	8 kHz	95.0	22.0	0.122	2.0	1.2	0.6	90°C	20
4055	100	67.20	5 kHz	130.0	24.0	0.088	2.0	1.2	1.0	90°C	20
4075	125	46.20	5 kHz	130.0	36.0	0.092	2.0	1.3	1.0	98°C	16
4090	150	38.91	8 kHz	156.0	40.0	0.056	2.0	1.5	1.0	108°C	16
4110	200	36.23	5 kHz	190.0	49.0	0.046	2.0	1.7	1.0	100°C	16
4160	250	30.13	5 kHz	270.0	70.0	0.029	2.0	1.8	1.0	108°C	14
4185	300/350	30.57	2 kHz	310.0	81.0	0.025	2.0	0.7	1.0	95°C	15
4220	400/450	27.13	2 kHz	370.0	96.0	0.020	2.0	0.8	1.0	100°C	15
4300	500+	21.76	2 kHz	500.0	130.0	0.014	2.1	0.9	1.0	95°C	15

Note: b8-04 = Energy Savings Coefficient
C6-02 = Carrier Frequency
E2-01 = Motor Rated Current
E2-03 = Motor No-Load Current
E2-05 = Motor Line-to-Line Resistance
L2-02 = Momentary Power Loss Ride-Thru Time
L2-03 = Momentary Power Loss Minimum Base Block Time
L2-04 = Momentary Power Loss Voltage Recovery Ramp Time
L8-02 = Overheat Pre-Alarm Level
L8-06 = Input Phase Loss Detection Level

B.3 Capacity Related Parameter Values

THIS PAGE INTENTIONALLY LEFT BLANK.



Appendix: C

Specifications

This appendix details the standard iQpump drive specifications.

C.1 Standard iQpump Drive Specifications.....	204
--	------------

C.1 Standard iQpump Drive Specifications

The standard iQpump drive specifications are listed in the following tables.

◆ 208-240 VAC

Table C.1 208-240 VAC iQpump Drive Specifications

Model Number CIMR-P7U□-107		20P4	20P7	21P5	22P2	23P7	25P5	27P5	2011	2015	2018	2022	2030	
Output Ratings	Rated output capacity (kVA)	1.4	1.8	3.0	4.1	6.4	8.8	12.0	18.0	23.0	29.0	34.0	44.0	
	Motor HP	208 V	0.5/0.75	1	1.5/2	3	5	7.5	10	15	20	25	30	40
		230 V	0.5/0.75	1	1.5/2	3	5	7.5	10	15	20	25	30	40
	Rated output current (A)	3.6	4.6	7.8	10.8	16.8	23.0	31.0	46.2	59.4	74.8	88.0	115.0	
	Max. output voltage (V)	3-phase; 200, 208, 220, 230, or 240 VAC (Proportional to input voltage)												
Max. output frequency (Hz)	120 Hz													
Power Supply Characteristics	Rated voltage (V)	3-phase, 200/208/220/230/240 VAC, 50/60 Hz												
	Rated frequency (Hz)	3-phase, 200/208/220/230/240 VAC, 50/60 Hz												
	Rated input current (A)	4.3	5.5	9.4	13	20	24	37	53	70	89	98	120	
	Allowable voltage fluctuation	+ 10%, - 15%												
Allowable frequency fluctuation	±5%													
Control Characteristics	Measures for power supply harmonics	DC Reactor	Optional										Built-in	
		12-Pulse Rectification	Not possible										Possible	
Note: The maximum applicable motor output is given for a standard 4-pole motor. When selecting the actual motor and Drive, be sure that the Drive's rated output current is applicable for the motor's rated current. A phase-shifting transformer is required on the power supply for 12-pulse rectification.														

Table C.1 208-230 VAC iQpump Drive Specifications (Continued)

Model Number CIMR-P7U□-107		2037	2045	2055	2075	2090	2110	
Output Ratings	Rated output capacity (kVA)	62.0	73.0	82	120.0	140.0	160.0	
	Motor HP	208V	50	60	75	100	125	150
		230V	50/60	75	—	100/125	—	150
	Rated output current (A)	162.0	192.0	215	312.0	360.0	415.0	
	Max. output voltage (V)	3-phase; 200, 208, 220, 230, or 240 VAC (Proportional to input voltage)						
Max. output frequency (Hz)	120 Hz							
Power Supply Characteristics	Rated voltage (V)	3-phase, 200/208/220/230/240 VAC, 50/60 Hz						
	Rated frequency (Hz)	3-phase, 200/208/220/230/240 VAC, 50/60 Hz						
	Rated input current (A)	180	212	237	350	396	457	
	Allowable voltage fluctuation	+ 10%, - 15%						
Allowable frequency fluctuation	±5%							
Control Characteristics	Measures for power supply harmonics	DC Reactor	Built-in					
		12-Pulse Rectification	Possible					
Note: The maximum applicable motor output is given for a standard 4-pole motor. When selecting the actual motor and Drive, be sure that the Drive's rated output current is applicable for the motor's rated current. A phase-shifting transformer is required on the power supply for 12-pulse rectification.								

◆ 480 VAC

Table C.2 480 VAC iQpump Drive Specifications

Model Number CIMR-P7U□-107		40P4	40P7	41P5	42P2	43P7	45P5	47P5	49P0	4011	4015	4018
Output Ratings	Rated output capacity (kVA)	1.4	1.6	2.8	4.0	5.8	9.5	13.0	16.0	21.0	26.0	30.0
	Motor HP (460V)	0.5/0.75	1	1.5/2	3	5	7.5	10	15	20	25	30
	Rated output current (A)	1.8	2.1	3.7	5.3	7.6	12.5	17.0	21.0	27.0	34.0	40.0
	Max. output voltage (V)	3-phase; 380, 400, 415, 440, 460, or 480 VAC (Proportional to input voltage.)										
	Max. output frequency (Hz)	120 Hz										
Power Supply Characteristics	Rated voltage (V) Rated frequency (Hz)	3-phase, 380, 400, 415, 440, 460 or 480 VAC, 50/60 Hz										
	Rated input current (A)	2.2	2.5	4.4	6.4	9.0	15	20	26	33	40	48
	Allowable voltage fluctuation	+ 10%, - 15%										
	Allowable frequency fluctuation	±5%										
Control Characteristics	Measures for power supply harmonics	DC Reactor	Optional									
		12-pulse Rectification	Not possible									

Table C.2 480 VAC iQpump Drive Specifications (Continued)

Model Number CIMR-P7U□-107		4024	4030	4037	4045	4055	4075	4090	4110	4160	4185	4220	4300
Output Ratings	Rated output capacity (kVA)	40.0	51.0	59.0	73.0	95.0	120.0	140.0	180.0	230.0	315.0	390.0	510.0
	Motor HP (460V)	40	50	60	75	100	125	150	200	250	300/350	400/450	500+
	Rated output current (A)	52.0	67.2	77.0	96.0	125.0	156.0	180.0	240.0	304.0	414.0	515.0	675.0
	Max. output voltage (V)	3-phase, 380, 400, 415, 440, 460 or 480 VAC (Proportional to input voltage)											
	Max. output frequency (Hz)	120 Hz											
Power Supply Characteristics	Max. voltage (V) Rated frequency (Hz)	3-phase, 380, 400, 415, 440, 460, or 480 VAC, 50/60 Hz											
	Rated input current (A)	57	74	85	106	134	172	198	264	334	456	567	743
	Allowable voltage fluctuation	+ 10%, - 15%											
	Allowable frequency fluctuation	±5%											
Control Characteristics	Measures for power supply harmonics	DC Reactor	Built-in										
		12-Pulse Rectification	Possible										

Note: The maximum applicable motor output is given for a standard 4-pole motor. When selecting the actual motor and Drive, be sure that the Drive's rated output current is applicable for the motor's rated current.
A 3-wire phase-shifting transformer is required on the power supply for 12-pulse rectification.

C.1 Standard iQpump Drive Specifications

Table C.3 Common iQpump (P7U) Drive Specifications

Model Number CIMR-P7U□-107		Specification
Control Characteristics	Control method	Sine wave PWM V/f control
	Speed range	40:1
	Speed control accuracy	±2 to 3% (77°F ± 50°F) (25°C ± 10°C)
	Frequency accuracy (temperature characteristics)	Digital references: ± 0.01% (14°F to 104°F) (-10°C to +40°C)
		Analog references: ±0.1% (77°F ± 50°F) (25°C ± 10°C)
	Frequency setting resolution	Digital references: 0.01 Hz
		Analog references: 0.025/50 Hz (10 bit with sign)
	Frequency setting signal (Speed Command)	0-10 Vdc, 4-20 mA
Acceleration/Deceleration time	0.0 to 6000.0 s (2 selectable combinations of independent acceleration and deceleration settings)	
Main control functions	Restarting for momentary power loss, bi-directional speed search, overtorque detection, 5 preset speeds, acceleration/deceleration time changes, S-curve acceleration, 3-wire sequence, auto-tuning, cooling fan ON/OFF control, torque compensation, jump frequencies, upper and lower limits for frequency references, DC braking for starting and stopping, high-slip braking, PI control (with sleep function), energy-saving control, Modbus communications (RS-485/422, 19.2 kbps maximum), fault reset, and copy function	
Protective Functions	Motor protection	Protection by electronic thermal overload relay
	Fuse blown protection	Stops for fuse blown
	Overload capacity and maximum current	110% of rated output current for 60 seconds
	Overvoltage protection	208-240 VAC: Stops when main-circuit DC voltage is above 410V
		480 VAC: Stops when main-circuit DC voltage is above 820V
	Undervoltage protection	208-240 VAC: Stops when main-circuit DC voltage is below 190V
		480 VAC: Stops when main-circuit DC voltage is below 380V
	Momentary power loss ridthru	Power Interruptions of 15 ms or more By selecting the momentary power loss method, operation can be continued if power is restored within 2sec
	Cooling fin overheating	Protection by thermistor
Stall prevention	Stall prevention during acceleration, deceleration, or running	
Grounding protection	Protection by electronic circuits. (50% of inverter rated current)	
Charge indicator	Lit when the main circuit DC voltage is approx. 50 Vdc or more	
Enclosure Type	Enclosed wall-mounted type (NEMA 1): CIMR-P7U20P4 thru 2030 and 40P4 thru 4055 Open chassis type (IP00): CIMR-P7U2022 thru 2110 and 4030 thru 4300	
Environment	Ambient operating temperature	14°F to 104°F (-10°C to 40°C) NEMA 1 type 14°F to 113°F (-10°C to 45°C) Open chassis type
	Ambient operating humidity	95% max. (with no condensation)
	Storage temperature	-4°F to 140°F (- 20°C to + 60°C) short-term temperature during transportation
	Application site	Indoor (no corrosive gas, dust, etc.)
	Altitude	3300 ft. (1000 m), higher altitudes by derate
	Vibration	10 to 20 Hz, 32 ft/sec ² (9.8 m/s ²) max.; 20 to 50 Hz, 6.5 ft/sec ² (2 m/s ²) max.
Approval Agencies	UL File E143427	



Appendix: D

Communication

This appendix details the specifications, connections, and programming of the iQpump drive for Modbus communications. This iQpump drive also contains embedded APOGEE™ FLN and Metasys® communication protocols. For details regarding APOGEE™ FLN, please refer to the P7 APOGEE™ FLN Technical Manual (TM.iQp.21). For details regarding Metasys®, please refer to the Technical Manual (TM.iQp.22). These two documents can be found on the CD-ROM included with this iQpump drive or at <http://iQpump.yaskawa.com>.

D.1 Using Modbus Communication	208
D.2 Modbus Function Code Details	212
D.3 Modbus Data Tables	214
D.4 Modbus Self-Diagnosis	219

D.1 Using Modbus Communication

Serial communication can be performed with Direct Digital Controllers (DDCs) or similar devices using the Modbus protocol.

◆ Modbus Communication Configuration

Modbus communication is configured using 1 master (PLC) and a maximum of 31 slaves. Serial communication between master and slave is normally initiated by the master and responded to by the slaves.

The master performs serial communication with one slave at a time. Consequently, the slave address of each slave must be initially set, so that the master can perform serial communication using that address. Slaves receiving commands from the master perform the specified functions, and send a response back to the master.

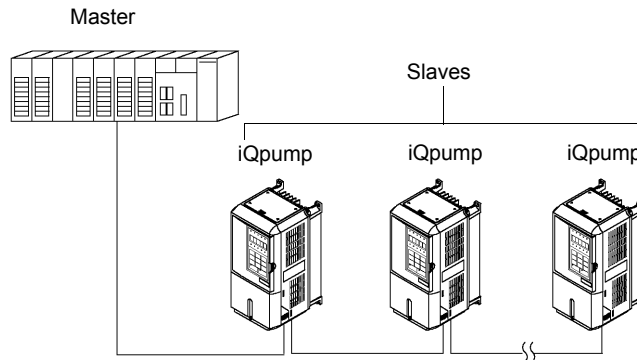

Figure D.1 Example of Connections between Master and Drive

◆ Communication Specifications

The Modbus communication specifications are shown below:

Table D.1 Modbus Communication Specifications

Item	Specifications	
Interface	RS-422, RS-485	
Communications Cycle	Asynchronous (Start-stop synchronization)	
Communications Parameters	Baud rate:	Select from 1200, 2400, 4800, 9600, and 19200 bps.
	Data length:	8 bits fixed
	Parity:	Select from even, odd, or none.
	Stop bits:	1 bit selected
Communications Protocol	Modbus	
Number of Connectable Units	31 units max.	

◆ Communication Connection Terminal

Modbus communication uses the following terminals: S+, S-, R+, and R-. The terminating resistance must be turned ON only if the iQpump drive is at the very end of the Serial Communication chain. Set the terminating resistance by turning ON pin 1 of switch S1.

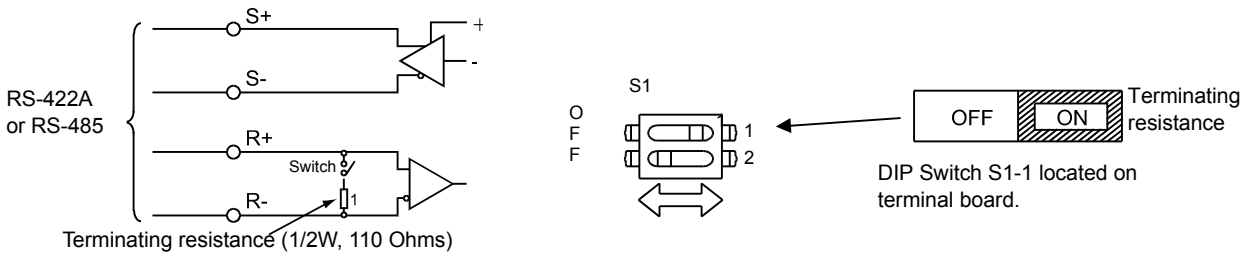

Figure D.2 Communication Connection Terminals and Terminating Resistance

IMPORTANT:

1. Separate the communication cables from the main circuit cables and control circuit wiring.
2. Use shielded cables for the communication cable, and use proper shield clamps.
3. When using RS-485 communication, connect S+ to R+, and S- to R-, on the control circuit terminal board. See **Figure D.3** below.
4. Shield at one end only.

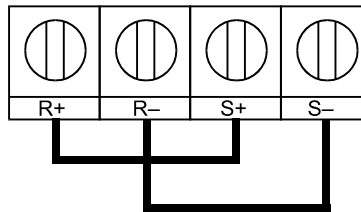

Figure D.3 RS-485 Communication Connection

◆ Procedure for Setting Up Communication

Use the following procedure to perform communication with the DDC.

1. Turn OFF the input to the iQpump drive power and connect the communication cable between the PLC and the iQpump drive.
2. Turn ON the input power to the iQpump drive.
3. Set the required communication parameters (H5-01 to H5-09) using the Digital Operator.
4. Turn OFF the input to the iQpump drive power, and check that the Digital Operator display has completely disappeared.
5. Turn ON the input power to the iQpump drive once again.
6. Perform communication with the DDC.

D.1 Using Modbus Communication

■ Related Parameters

Table D.2 Serial Communication Related Parameters

Parameter No.	Modbus Address	Parameter Name Digital Operator Display	Description	Setting Range	Factory Setting	Menu Location	Page No.
b1-01	0180H	Frequency Reference Selection Reference Source	Selects the speed command (frequency reference) input source. 0: Operator - Digital preset speed d1-01 1: Terminals - Analog Input Terminal A1 (or Terminal A2 see parameter H3-13) 2: Serial Com - RS-485 terminals R+, R-, S+ and S- 3: Option PCB - Option board connected at 2CN	0 to 3	0	Pump Quick Setup	
b1-02	0181H	Run Command Selection Run Source	Selects the run command input source. 0: Operator - "Hand" and "Off" keys on digital operator 1: Terminals - Contact Closure on Terminal S1 2: Serial Com - RS-485 terminals R+, R-, S+ and S- 3: Option PCB - Option board connected at 2CN	0 to 3	0	Pump Quick Setup	
H5-01	0425H	Drive Node Address Serial Com Adr	Selects Drive station node number (address) for terminals R+, R-, S+, S-.* Note: An address of "0" disables serial com.	0 to 20 (H5-08=0) 0 to FF (H5-08=1) 0 to 63 (H5-08=2)	1F	Programming	
H5-02	0426H	Communication Speed Selection Serial Baud Rate	Selects the baud rate for terminals R+, R-, S+ and S-.* 0: 1200 Baud 1: 2400 Baud 2: 4800 Baud (APOGEE FLN) 3: 9600 Baud (Metasys N2) 4: 19200 Baud	0 to 4	3	Programming	
H5-03	0427H	Communication Parity Selection Serial Com Sel	Selects the communication parity for terminals R+, R-, S+ and S-.* 0: No Parity 1: Even Parity 2: Odd Parity	0 to 2	0	Programming	
H5-04	0428H	Stopping Method after Communication Error Serial Fault Sel	Selects the stopping method when a communication error is detected. 0: Ramp to Stop 1: Coast to Stop 2: Fast-Stop 3: Alarm Only	0 to 3	3	Programming	
H5-05	0429H	Communication Error Detection Selection Serial Flt Dctt	Enables or disables the communications timeout detection function. 0: Disabled - A communications loss will NOT cause a communications fault. 1: Enabled - If communications are lost for more than the time specified in parameter H5-09, a communications fault will occur.	0 or 1	1	Programming	
H5-06	042AH	Drive Transmit Wait Time Transmit WaitTIM	Sets the time from when the Drive receives data to when the Drive sends data.	5 to 65	5 ms	Programming	
H5-07	042BH	RTS Control Selection RTS Control Sel	Enables or disables "request to send" (RTS) control: 0: Disabled (RTS is always on) 1: Enabled (RTS turns on only when sending)	0 or 1	1	Programming	
H5-09	0435H	Communication Error Detection Time CE Detect Time	Determines how long communications must be lost before a fault is annunciated. Works in conjunction with parameters H5-05 and H5-04.	0.0 to 10.0 (H5-08=0) 0.0 to 10.0 (H5-08=1) 0.0 to 90.0 (H5-08=2)	2.0 sec	Programming	

◆ Denotes that parameter can be changed when the iQpump drive is running.

* After these parameters are changed, iQpump drive power must be cycled before the changes will take effect.

Hex, see **page A-30**.

Modbus communication can perform the following operations regardless of the settings in b1-01 and b1-02:

1. Monitoring operation status of the iQpump drive.
2. Setting and reading iQpump drive parameters.
3. Resetting faults.
4. Input multi-function commands.

IMPORTANT: An OR operation is performed between the multi-function command input from the DDC and the command input from multi-function digital input terminals S3 to S7.

■ **Message Format**

In Modbus communication, the master sends commands to the slave, and the slave responds. The message format is configured for both sending and receiving as shown below. The length of the data packets is changed by the command (function) contents.

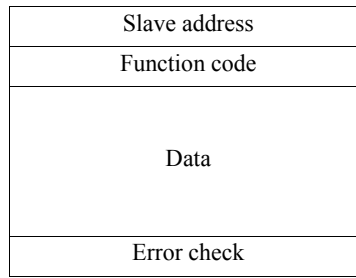

Figure D.4 Message Format

The space between messages must support the following:

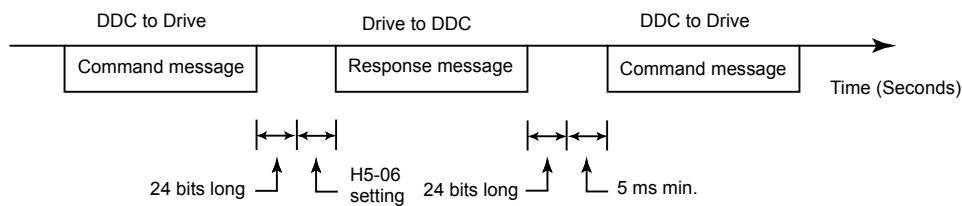

Figure D.5 Message Spacing

Slave Address

Set the iQpump drive address from 0 to 32. If 0 is selected, commands from the master will be broadcast (i.e., the iQpump drive will not return responses).

Function Code

The function code specifies commands. There are four function codes, as shown below.

Table D.3 Function Codes

Function Code (Hexadecimal)	Function	Command Message		Response Message	
		Min. (Bytes)	Max. (Bytes)	Min.* (Bytes)	Max. (Bytes)
03H	Reading/Holding Register Contents	8	8	7	37
06H	Write In Single Holding Register	8	8	8	8
08H	Loopback Test	8	8	8	8
10H	Write In Several Holding Registers	11	41	8	8

* Minimum bytes for a normal Response Message (error response message is always 5 bytes).

Data

Configure consecutive data by combining the storage register address (test code for a loopback address) and the data the register contains. The data length changes depending on the command details.

Error Check

Errors are detected during communication using CRC-16. Perform calculations using the following method:

1. The factory setting for CRC-16 communication is typically zero, but when using the Modbus system, set the factory setting to one (e.g., set all 16 bits to 1).
2. Calculate CRC-16 using MSB as slave address LSB, and LSB as the MSB of the final data.
3. Calculate CRC-16 for response messages from the slaves and compare them to the CRC-16 in the response messages.

D.2 Modbus Function Code Details

◆ Reading/Holding Register Contents (03H)

Read the contents of the storage register only for specified quantities. The addresses must be consecutive, starting from a specified address. The data content of the storage register are separated into higher 8 bits and lower 8 bits.

The following table shows message examples when reading status signals, error details, data link status, and frequency references from the slave 2 drive.

Command Message			Response Message (During Normal Operation)			Response Message (During Error)		
Slave Address		02H	Slave Address		02H	Slave Address		02H
Function Code		03H	Function Code		03H	Function Code		83H
Start Address	Higher	00H	Data quantity		08H	Error code		03H
	Lower	20H	1st storage register	Higher	00H	CRC-16	Higher	F1H
Quantity	Higher	00H		Lower	65H		Lower	31H
	CRC-16	Higher	45H	Next storage register	Higher	00H		
Lower		F0H	Lower		00H			
			Next storage register	Higher	00H			
				Lower	00H			
			Next storage register	Higher	01H			
				Lower	F4H			
			CRC-16	Higher	AFH			
				Lower	82H			

Figure D.6 Function Code 03H Message Example

◆ Write In Single Holding Register (06H)

Command Message			Response Message (During Normal Operation)			Response Message (During Error)		
Slave address		01H	Slave address		01H	Slave address		01H
Function code		06H	Function code		06H	80H + Function Code		86H
Register Address	Upper	00H	Register Address	Upper	00H	Error code		21H
	Lower	01H		Lower	01H	CRC-16	Upper	82H
Setting Data	Upper	00H	Setting Data	Upper	00H		Lower	78H
	Lower	03H		Lower	03H			
CRC-16	Upper	98H	CRC-16	Upper	98H			
	Lower	0BH		Lower	0BH			

Figure D.7 Function Code 06H Message Example

◆ Loopback Test (08H)

The loopback test returns the command message directly as the response message without changing the contents to check the communications between the master and slave. Set user-defined test code and data values.

The following table shows a message example when performing a loopback test with the slave 1 drive.

Table D.4 Function Code 08H Message Example

Command Message			Response Message (During Normal Operation)			Response Message (During Error)		
Slave address		01H	Slave address		01H	Slave address		01H
Function code		08H	Function code		08H	Function code		89H
Test Code	Higher	00H	Test Code	Higher	00H	Error Code		01H
	Lower	00H		Data	Lower	00H	CRC-16	Higher
Data	Higher	A5H	Data		Higher	A5H		CRC-16
	Lower	37H		CRC-16	Lower	37H	Higher	
CRC-16	Higher	DAH	CRC-16		Higher	DAH	Lower	8DH
	Lower	8DH		Lower	8DH	Lower	8DH	

◆ Write In Several Holding Registers (10H)

Write the specified data to the registers from the specified addresses. The written data must be consecutive, starting from the specified address in the command message: Higher 8 bits, then lower 8 bits, in storage register address order.

The following table shows an example of a message when a forward run command has been set at a speed command of 60.0 Hz in the slave 1 Drive by the PLC.

Table D.5 Function Code 10H Message Example

Command Message			Response Message (During Normal Operation)			Response Message (During Error)		
Slave Address		01H	Slave Address		01H	Slave Address		01H
Function Code		10H	Function Code		10H	Function Code		90H
Start Address	Higher	00H	Start Address	Higher	00H	Error code		02H
	Lower	01H		Quantity	Lower	01H	CRC-16	Higher
Quantity	Higher	00H	Quantity		Higher	00H		CRC-16
	Lower	02H		CRC-16	Lower	02H	Higher	
No. of data		04H	CRC-16		Higher	10H	Lower	08H
Lead data	Higher	00H		Lower	08H			
	Lower	01H						
Next data	Higher	02H						
	Lower	58H						
CRC-16	Higher	63H						
	Lower	39H						

* No. of data = 2 x (quantity)

IMPORTANT: Set the number of data specified using command messages as quantity of specified messages x 2. Handle response messages in the same way.

D.3 Modbus Data Tables

The data tables are shown below. The types of data are as follows: Reference data, monitor data and broadcast data.

◆ Reference Data

The reference data table is shown below. Reference data can be read and written to.

Table D.6 Reference Data

Register No.	Contents		
0000H	Reserved		
0001H	Frequency reference		
	Bit 0	Run Forward 1: Run Forward	
	Bit 1	Run Reverse 1: Run Reverse	
	Bit 2	External fault 1: Fault (EFO)	
	Bit 3	Fault reset 1: Reset command	
	Bit 4	ComNet	
	Bit 5	ComCtrl	
	Bit 6	Multi-function digital input command 3	
	Bit 7	Multi-function digital input command 4	
	Bit 8	Multi-function digital input command 5	
	Bit 9	Multi-function digital input command 6	
	Bit A	Multi-function digital input command 7	
Bits B to F	Not used		
0002H	Frequency reference (Set units using parameter o1-03)		
0003H to 0005H	Not used		
0006H	PI Setpoint		
0007H	Analog output 1 setting (-11 V = 726 to 11 V = 726) → 10 V = 660		
0008H	Analog output 2 setting (-11 V = 726 to 11 V = 726) → 10 V = 660		
0009H	Multi-function contact output setting		
	Bit 0	Digital output 1 (Terminal M1-M2) 1: ON 0: OFF	
	Bit 1	Digital output 2 (Terminal M3-M4) 1: ON 0: OFF	
	Bit 2	Not Used	
	Bits 3 to 5	Not used	
	Bit 6	Set fault contact (terminal MA-MC) output using bit 7. 1: ON 0: OFF	
	Bit 7	Fault contact (terminal MA-MC) 1: ON 0: OFF	
Bits 8 to F	Not used		
000AH to 000EH	Not used		
000FH	Reference selection settings		
	Bit 0	Not used	
	Bit 1	Input PI setpoint 1: Enabled 0: Disabled	
	Bits 3 to B	Not used	
	C	Broadcast data terminal S5 input 1: Enabled 0: Disabled	
	D	Broadcast data terminal S6 input 1: Enabled 0: Disabled	
	E	Broadcast data terminal S7 input 1: Enabled 0: Disabled	
F	Not used		

Write 0 to all unused bits. Also, do not write data to reserved registers.

Monitor Data

The following table shows the monitor data. Monitor data can only be read.

Table D.7 Monitor Data

Register No.	Contents	
0020H	Drive status	
	Bit 0	Operation 1: Operating 0: Stopped
	Bit 1	Reverse operation 1: Reverse operation 0: Forward operation
	Bit 2	Drive startup complete 1: Completed 0: Not completed
	Bit 3	Fault 1: Fault
	Bit 4	Data setting error 1: Error
	Bit 5	Multi-function digital output 1 (terminal M1 - M2) 1: ON 0: OFF
	Bit 6	Multi-function digital output 2 (terminal M3 - M4) 1: ON 0: OFF
	Bit 7	Not used
	Bits 8 to F	Not used
0021H	Fault details	
	Bit 0	Overcurrent (OC) Ground fault (GF)
	Bit 1	Main circuit overvoltage (OV)
	Bit 2	Drive overload (OL2)
	Bit 3	Drive overheat (OH1, OH2)
	Bit 4	Not used
	Bit 5	Fuse blown (PUF)
	Bit 6	PI feedback reference lost (FbL)
	Bit 7	External error (EF, EFO)
	Bit 8	Hardware error (CPF)
	Bit 9	Motor overload (OL1) or overtorque 1 (OL3) detected
	Bit A	PG broken wire detected (PGO), Overspeed (OS), Speed deviation (DEV)
	Bit B	Main circuit undervoltage (UV) detected
	Bit C	Main circuit undervoltage (UV1), control power supply error (UV2), inrush prevention circuit error (UV3), power loss
Bit D	Missing output phase (LF)	
Bit E	Modbus communications error (CE)	
Bit F	Operator disconnected (OPR)	
0022H	Data link status	
	Bit 0	Writing data
	Bit 1	Not used
	Bit 2	Not used
	Bit 3	Upper and lower limit errors
	Bit 4	Data integrity error
		Bits 5 to F
0023H	Frequency reference	U1-01
0024H	Output frequency	U1-02
0025H	Output voltage reference	U1-06
0026H	Output current	U1-03
0027H	Output power	U1-08
0028H	Torque reference	U1-09
0029H	Not used	
002AH	Not used	
002BH	Sequence input status	
	Bit 0	Input terminal S1 1: ON 0: OFF
	Bit 1	Input terminal S2 1: ON 0: OFF
	Bit 2	Multi-function digital input terminal S3 1: ON 0: OFF
	Bit 3	Multi-function digital input terminal S4 1: ON 0: OFF
	Bit 4	Multi-function digital input terminal S5 1: ON 0: OFF
	Bit 5	Multi-function digital input terminal S6 1: ON 0: OFF
	Bit 6	Multi-function digital input terminal S7 1: ON 0: OFF
	Bits 7 to F	Not used

D.3 Modbus Data Tables

Register No.	Contents	
002CH	Drive status	
	Bit 0	Operation 1: Operating
	Bit 1	Zero speed 1: Zero speed
	Bit 2	Frequency agree 1: Matched
	Bit 3	Desired frequency agree 1: Matched
	Bit 4	Frequency detection 1 1: Output frequency \leq L4-01
	Bit 5	Frequency detection 2 1: Output frequency \geq L4-01
	Bit 6	Drive startup completed 1: Startup completed
	Bit 7	Low voltage detection 1: Detected
	Bit 8	Baseblock 1: Drive output baseblock
	Bit 9	Frequency reference mode 1: Not communication 0: Communication
	Bit A	Run command mode 1: Not communication 0: Communication
	Bit B	Overtorque detection 1: Detected
	Bit C	Frequency reference lost 1: Lost
	Bit D	Retrying error 1: Retrying
Bit E	Error (including Modbus communications time-out) 1: Error occurred	
Bit F	Modbus communications time-out 1: Timed out	
002DH	Multi-function digital output status	
	Bit 0	Multi-function digital output 1 (terminal M1-M2) 1: ON 0: OFF
	Bit 1	Multi-function digital output 2 (terminal M3-M4): 1: ON 0: OFF
	Bit 2	Not used
	Bits 3 to F	Not used
002EH - 0030H	Not used	
0031H	Main circuit DC voltage	
0032H - 0037H	Not used	
0038H	PI feedback level (Input equivalent to 100%/Max. output frequency; 10/1%; without sign)	
0039H	PI input level (\pm 100%/ \pm Max. output frequency; 10/1%; with sign)	
003AH	PI output level (\pm 100%/ \pm Max. output frequency; 10/1%; with sign)	
003BH	CPU software number	
003CH	Flash software number	
003DH	Communication error details	
	Bit 0	CRC error
	Bit 1	Invalid data length
	Bit 2	Not used
	Bit 3	Parity error
	Bit 4	Overrun error
	Bit 5	Framing error
	Bit 6	Time-out
	Bits 7 to F	Not used
003EH	KVA setting	
003FH	Control method	
Note: Communication error details are stored until an error reset is input (errors can be reset while the Drive is operating).		

Broadcast Data

The following table shows the broadcast data. Broadcast data can be written to.

Table D.8 Broadcast Data

Register Address	Contents	
0001H	Operation signal	
	Bit 0	Run command 1: Operating 0: Stopped
	Bit 1	Reverse operation command 1: Reverse 0: Forward
	Bits 2 and 3	Not used
	Bit 4	External error 1: Fault (set using H1-01)
	Bit 5	Error Fault 1: Reset command (set using H1-02)
	Bits 6 to B	Not used
	Bit C	Multi-function digital input terminal S5 input
	Bit D	Multi-function digital input terminal S6 input
	Bit E	Multi-function digital input terminal S7 input
0002H	Frequency reference	30000/100%
Note: Bit signals not defined in the broadcast operation signals use local node data signals continuously.		

Enter Command

When writing parameters to the Drive from the PLC using Modbus communication, the parameters are temporarily stored in the constant data area in the Drive. To enable these parameters in the parameter data area, use the Enter command.

There are two types of Enter commands:

1. Enter commands that enable parameter data in RAM
2. Enter commands that write data to EEPROM (non-volatile memory) in the Drive at the same time as enabling data in RAM.

The following table shows the Enter command data. Enter command data can only be written.

The Enter command is enabled by writing 0 to register number 0900H or 0901H.

Table D.9 Enter Command

Register No.	Contents
0900H	Write parameter data to EEPROM
0910H	Parameter data is not written to EEPROM, but refreshed in RAM only.

IMPORTANT: The maximum number of times you can write to EEPROM using the Drive is 100,000. Do not frequently execute Enter commands (0900H) written to EEPROM. The Enter command registers are write-only. Consequently, if reading these registers, the register address will become invalid (Error code: 02H).

D.3 Modbus Data Tables

Error Codes

The following table shows Modbus communication error codes.

Table D.10 Error Codes

Error Code	Contents
01H	Function code error A function code other than 03H, 08H, or 10H has been set by the PLC.
02H	Invalid register number error <ul style="list-style-type: none">The register address you are attempting to access is not recorded anywhere.With broadcast sending, a start address other than 0000H, 0001H, or 0002H has been set.
03H	Invalid quantity error <ul style="list-style-type: none">The number of data packets being read or written is outside the range of 1 to 16.In write mode, the number of data packets in the message is not No. of packets x 2.
21H	Data setting error <ul style="list-style-type: none">Upper limit or lower limit error has occurred in the control data or when writing parameters.When writing parameters, the parameter setting is invalid.
22H	Write mode error <ul style="list-style-type: none">Attempting to write parameters to the Drive during run.Attempting to write via Enter commands during run.Attempting to write parameters other than A1-00 to A1-05, E1-03, or 02-04 when a CPF03 (defective EEPROM) fault has occurred.Attempting to write read-only data.
23H	Writing during main circuit undervoltage (UV) fault <ul style="list-style-type: none">Writing parameters to the Drive during UV (main circuit undervoltage) alarm.Writing via Enter commands during UV (main circuit undervoltage) alarm.
24H	Writing error during parameters processing Attempting to write parameters while processing parameters in the Drive.

Slave Not Responding

In the following cases, the slave will ignore the write function.

- When a communication error (overrun, framing, parity, or CRC-16) is detected in the command message.
- When the slave address in the command message and the slave address in the Drive do not agree.
- When the data that configures the message and the data time length exceed 24 bits.
- When the command message data length is invalid.

IMPORTANT: If the slave address specified in the command message is 0, all slaves execute the write function, but do not return response messages to the master.

D.4 Modbus Self-Diagnosis

The iQpump drive has a built-in function for self-diagnosing the operations of serial communication interface circuits. The self-diagnosis function connects the communication parts of the send and receive terminals, receives the data sent by the iQpump drive, and checks if communication is being performed normally.

Perform the self-diagnosis function using the following procedure.

1. Turn ON the power supply to the iQpump drive, and set parameter H1-05 (Terminal S7 Function Selection) to 67 (Comm Test Mode).
2. Turn OFF the power supply to the iQpump drive.
3. Perform wiring according to the following diagram while the power supply is turned OFF.
4. Turn ON the terminating resistance. (Turn ON pin 1 on DIP switch 1.)
5. Turn ON the power supply to the iQpump drive again.

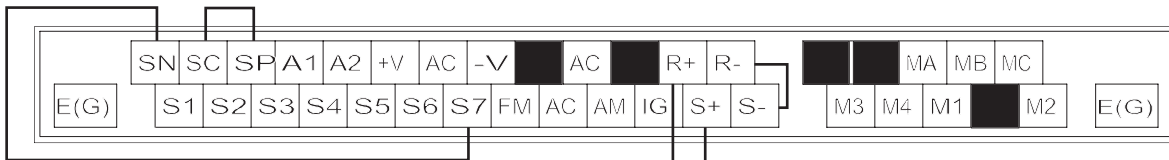

Figure D.8 Communication Terminal Connection for Self -Diagnosis Function

6. During normal self-diagnostic operation, the Digital Operator displays the frequency reference value. If an error occurs, a CE (Modbus communication error) alarm will be displayed on the Digital Operator, the fault contact output will be turned ON, and the iQpump drive operation ready signal will be turned OFF.

THIS PAGE INTENTIONALLY LEFT BLANK.



Appendix: E

Peripheral Devices

This appendix describes recommended branch short circuit protection and peripheral devices.

E.1 Branch Circuit Short Circuit Protection	222
E.2 Branch Circuit Overload Protection	224
E.3 Peripheral Devices	224
E.4 Third Party Serial Communication Converters	
RS232-RS485 / USB - RS485 Converters	225
E.5 PumpScada Software	227
E.6 Energy Savings Estimation Software	227

E.1 Branch Circuit Short Circuit Protection

The following peripheral devices may be required between the AC main circuit power supply and the iQpump drive input terminals L1(R), L2(S), and L3(T). Refer to applicable codes to determine the devices necessary for a given installation. Use Table E.1 or E.2 when selecting fuses and circuit breakers per the NEC. When selecting semiconductor fuses to provide iQpump drive input I²t protection and comply with UL, CSA, NEC, and CEC branch circuit short circuit protection requirements, select one of the fuses in Table E.3 or E.4.

- Fuse Type:** UL designated Time-Delay or Non-Time-Delay Fuse
 Class: CC, J, T, RK1 or RK5
 Designators (typical): KTK, FNQ, FRS, LPJ, LPS, JKS, JJN, or JJS
 Voltage Rating: 250 V for Drives with 208-240 V input
 600 V for Drives with 480 V input
- Circuit Breaker Type:** Inverse Time (MCCB) or Instantaneous Trip (MCP)
 Voltage Rating: 600V

Table E.1 Recommended Fuse and Circuit Breaker Ratings per NEC (208-240 Vac Input)

Model CIMR-P7U□-107	Hp	Input Amps *1 (Continuous Rating)	Output Amps *1 (Continuous Rating)	Fuse Selection Criteria		Circuit Breaker Selection Criteria
				Maximum Time-Delay Fuse Rating (A)	Maximum Non-Time-Delay Fuse Rating (A)	Maximum CB Rating (A)
20P4	0.5/0.75	4.3	3.6	6	12	15
20P7	1	5.5	4.6	8	12	15
21P5	1.5/2	9.4	7.8	15	15	15
22P2	3	13	10.8	20	20	20
23P7	5	20	16.8	30	30	35
25P5	7.5	24	23	40	50	45
27P5	10	37	31	60	80	80
2011	15	53	46.2	80	80	100
2015	20	70	59.4	110	125	125
2018	25	89	74.8	125	150	150
2022	30	98	88	150	150	175
2030	40	120	115	200	200	225
2037	50	180	162	250	250	300
2045	60	212	192	300	300	350
2055	75	237	215	350	350	450
2075	75/100	350	312	450	450	600
2090	125	396	360	600	600	700
2110	150	457	415	700	700	900

*1 Input and Output Amps are based on the Normal Duty (ND) current rating. Consult the Specification section for details on the Heavy Duty (HD) and Normal Duty (ND) ratings.

Table E.2 Recommended Fuse and Circuit Breaker Ratings per NEC (480 Vac Input)

Model CIMR-P7U□-107	Hp	Input Amps *1 (Continuous Rating)	Output Amps *1 (Continuous Rating)	Fuse Selection Criteria		Circuit Breaker Selection Criteria
				Maximum Time-Delay Fuse Rating (A)	Maximum Non-Time-Delay Fuse Rating (A)	Maximum CB Rating (A)
40P4	0.5/0.75	2.2	1.8	4	10	15
40P7	1	2.5	2.1	4	10	15
41P5	1.5/2	4.4	3.7	8	12	15
42P2	3	6.4	5.3	10	15	15
43P7	5	9	7.6	15	20	20
44P0	-	10.4	8.7	15	30	20
45P5	7.5	15	12.5	25	30	30
47P5	10	20	17	30	30	40
49P0	15	26	21	45	50	60
4011	20	33	27	45	50	60
4015	25	40	34	60	70	80
4018	30	48	40	70	80	90
4022	-	55	50.4	80	80	100
4024	40	57	52	100	100	125
4030	50	74	67.2	100	100	125
4037	60	85	77	125	125	150
4045	75	106	96	150	150	200
4055	100	134	125	200	200	225
4075	125	172	156	250	250	300
4090	150	198	180	300	300	400
4110	200	264	240	350	350	450
4132	-	286	260	400	400	600
4160	250	334	304	450	450	700
4185	300/350	456	414	600	600	800
4220	400/450	567	515	700	700	1000
4300	500+	743	675	900	900	1200

*1 Input and Output Amps are based on the Normal Duty (ND) current rating. Consult the Specification section for details on the Heavy Duty (HD) and Normal Duty (ND) ratings.

Table E.3 Semiconductor Fuses for Drive I2t Protection and Branch Circuit Short Circuit Protection (200V Series)

Drive Model CIMR-P7U□-107	Recommended			Alternate 1			Alternate 2		
	Fuse Mfr.	Model No.	Rating	Fuse Mfr.	Model No.	Rating	Fuse Mfr.	Model No.	Rating
20P4	Ferraz	A60Q12-2	600V, 12A	Ferraz	A070GRB006T13	700V, 6A	Bussmann	FWH-20A14F	500V, 20A
20P7	Ferraz	A60Q12-2	600V, 12A	Ferraz	A070GRB006T13	700V, 6A	Bussmann	FWH-20A14F	500V, 20A
21P5	Ferraz	A60Q15-2	600V, 15A	Ferraz	A70QS25-22F	700A, 25A	Bussmann	FWH-20A14F	500V, 20A
22P2	Ferraz	A60Q20-2	600V, 20A	Ferraz	6,900CPGRC14.51/25	690V, 25A	Bussmann	FWH-25A14F	500V, 25A
23P7	Ferraz	A60Q30-2	600V, 30A	Ferraz	A70QS32-14F	700A, 32A	Bussmann	FWH-45B	500V, 45A
25P5	Ferraz	A50P50-4	500V, 50A	Ferraz	A70QS50-14F	700V, 50A	Bussmann	FWH-80B	500V, 80A
27P5	Ferraz	A50P80-4	500V, 80A	Ferraz	A50QS70-4	500V, 70A	Bussmann	FWH-80B	500V, 80A
2011	Ferraz	A50P80-4	500V, 80A	Ferraz	A50QS100-4	500V, 100A	Bussmann	FWH-100B	500V, 100A
2015	Ferraz	A50P125-4	500V, 125A	Ferraz	A50QS150-4	500V, 150A	Bussmann	FWH-175B	500V, 175A
2018	Ferraz	A50P150-4	500V, 150A	Ferraz	A50QS175-4	500V, 175A	Bussmann	FWH-200B	500V, 200A
2022	Ferraz	A50P150-4	500V, 150A	Ferraz	A50QS200-4	500V, 200A	Bussmann	FWH-200B	500V, 200A
2030	Ferraz	A50P200-4	500V, 200A	Bussmann	FWH-200B	500V, 200A	Bussmann	FWH-225B	500V, 225A
2037	Ferraz	A50P250-4	500V, 250A	Ferraz	A30QS275-4	300V, 275A	Bussmann	170M4610	690V, 315A
2045	Ferraz	A50P300-4	500V, 300A	Ferraz	A30QS350-4	300V, 350A	Bussmann	FWH-350A	500V, 350A
2055	Ferraz	A50P350-4	500V, 350A	Bussmann	FWH-400A	500V, 400A	Bussmann	FWH-450A	500V, 450A
2075	Ferraz	A50P450-4	500V, 450A	Ferraz	A070URD33KI0550	700V, 550A	Bussmann	FWH-500A	500V, 500A
2090	Ferraz	A50P600-4	500V, 600A	Ferraz	A70P600-4	700V, 600A	Bussmann	FWH-600A	500V, 600A
2110	Ferraz	A50P600-4	500V, 600A	Ferraz	A70P700-4	700V, 700A	Bussmann	FWH-700A	500V, 700A

E.2 Branch Circuit Overload Protection

Table E.4 Semiconductor Fuses for Drive I²t Protection and Branch Circuit Short Circuit Protection (400V Series)

Table E.4 Semiconductor Fuses for Drive I ² t Protection and Branch Circuit Short Circuit Protection (400V Series)									
Drive Model CIMR-P7U□- 107	Recommended			Alternate 1			Alternate 2		
	Fuse Mfr.	Model No.	Rating	Fuse Mfr.	Model No.	Rating	Fuse Mfr.	Model No.	Rating
40P4	Ferraz	A60Q10-2	600V, 10A	Ferraz	A070GRB006T13	700V, 6A	Ferraz	A70QS16-14F	690V, 16A
40P7	Ferraz	A60Q10-2	600V, 10A	Ferraz	A070GRB006T13	700V, 6A	Ferraz	A70QS16-14F	690V, 16A
41P5	Ferraz	A60Q12-2	600V, 12A	Ferraz	6,900CPGRC14.51/25	690V, 25A	Ferraz	A70QS20-14F	690V, 20A
42P2	Ferraz	A60Q15-2	600V, 15A	Ferraz	A70QS25-22F	700V, 25A	Ferraz	A70QS20-14F	690V, 20A
43P7	Ferraz	A60Q20-2	600V, 20A	Ferraz	A70QS20-14F	700V, 20A	Ferraz	A70QS25-14F	690V, 25A
44P0	Ferraz	A60Q30-2	600V, 30A	Ferraz	A70QS32-14F	700V, 32A	Ferraz	A70QS40-14F	690V, 40A
45P5	Ferraz	A60Q30-2	600V, 30A	Ferraz	A70QS32-14F	700V, 32A	Ferraz	A70QS40-14F	690V, 40A
47P5	Ferraz	A60Q30-2	600V, 30A	Ferraz	A70QS40-14F	700V, 40A	-	-	-
49P0	Ferraz	A70P50-4	700V, 50A	Ferraz	A50QS50-4	500V, 50A	Bussmann	FWH-80B	500V, 80A
4011	Ferraz	A70P50-4	700V, 50A	Ferraz	A50QS50-4	500V, 50A	Bussmann	FWH-80B	500V, 80A
4015	Ferraz	A70P70-4	700V, 70A	Ferraz	A50QS80-4	500V, 80A	Bussmann	FWH-100B	500V, 100A
4018	Ferraz	A70P80-4	700V, 80A	Ferraz	A50QS100-4	500V, 100A	Bussmann	FWH-125B	500V, 125A
4022	Ferraz	A70P80-4	700V, 80A	Ferraz	A50QS100-4	500V, 100A	Bussmann	FWH-125B	500V, 125A
4024	Ferraz	A70P100-4	700V, 100A	Ferraz	A50QS125-4	500V, 125A	Bussmann	FWH-125B	500V, 125A
4030	Ferraz	A70P100-4	700V, 100A	Ferraz	A50QS125-4	500V, 125A	Bussmann	FWH-125B	500V, 125A
4037	Ferraz	A70P125-4	700V, 125A	Ferraz	A50QS125-4	500V, 125A	Bussmann	FWH-150B	500V, 150A
4045	Ferraz	A70P150-4	700V, 150A	Ferraz	A50QS150-4	500V, 150A	Bussmann	FWH-175B	500V, 175A
4055	Ferraz	A70P200-4	700V, 200A	Ferraz	A70QS200-4	700V, 200A	Bussmann	FWH-200B	500V, 200A
4075	Ferraz	A70P250-4	700V, 250A	Ferraz	A50QS250-4	500V, 250A	Bussmann	FWH-250A	500V, 250A
4090	Ferraz	A70P300-4	700V, 300A	Ferraz	A50QS300-4	500V, 300A	Bussmann	170M4611	690V, 350A
4110	Ferraz	A70P350-4	700V, 350A	Ferraz	A50P350-4	500V, 350A	Bussmann	170M4611	690V, 350A
4132	Ferraz	A70P400-4	700V, 400A	Ferraz	A70P500-4	700V, 500A	Bussmann	170M5610	690V, 500A
4160	Ferraz	A70P450-4	700V, 450A	Ferraz	A70QS700-4	700V, 700A	Bussmann	FWH-600A	500V, 600A
4185	Ferraz	A70P600-4	700V, 600A	Ferraz	A70QS700-4	700V, 700A	Bussmann	FWH-700A	500V, 700A
4220	Ferraz	A70P700-4	700V, 700A	Bussmann	FWH-800A	500V, 800A	Bussmann	FWH-1000A	500V, 1000A
4300	Ferraz	A70P900-4	700V, 900A	Bussmann	FWH-1000A	500V, 1000A	Bussmann	FWH-1200A	500V, 1200A

E.2 Branch Circuit Overload Protection

All models have built-in UL evaluated motor overload protection. Motor overload protection is also provided in accordance with the NEC and CEC. Additional branch circuit overload protection is not required for single motor applications.

E.3 Peripheral Devices

The following peripheral devices may be required to be mounted between the AC main circuit power supply and the iQpump drive input terminals R/L1, S/L2, and T/L3.

⚠ CAUTION

Never connect a general LC/RC noise filter to the iQpump drive output circuit.

Never connect a phase-advancing capacitor to the input or output sides, or a surge suppressor to the output side of the iQpump drive. When magnetic contactor is installed between the iQpump drive and the motor, never turn it on or off during operation.

For more details on peripheral devices, contact the manufacturer.

◆ Magnetic Contactor

Mount a surge protector on the coil. When using a magnetic contactor to start and stop the iQpump drive, do not exceed one start per hour.

◆ **AC and DC Reactor**

When using models P7U20P4 thru P7U2018 and P7U40P4 thru P7U4018 on a power supply transformer with a capacity of 600kVA or more, install an AC or DC reactor. The reactor improves the input power factor and provides protection to the rectifier circuit within the iQpump drive.

◆ **Noise filter**

Use a noise filter exclusively for the iQpump drive if radio noise generated from the iQpump drive causes other control devices to malfunction.

**E.4 Third Party Serial Communication Converters
RS232-RS485 / USB - RS485 Converters**

The iQpump drive has been tested with these Serial/USB to RS/485 converters listed in this document and approved for use with the PumpScada software. Identical converters can be used but proper communication is not guaranteed.

◆ **RS232 Serial Port to RS485 Converters**

Manufacturer: Telebyte, Inc
Model: Telebyte T285
Website: www.telebyteusa.com

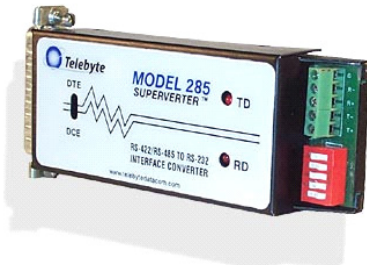

Table E.5 T285 Module Dipswitch Settings

	TD Control	RTS Control	220 Ohm Term	Two-Wire Mode	Four-wire Mode
Mode	SW1	SW2	SW3	SW4	SW5
RS-485 Two-Wire Transmitter enabled by TD	ON	OFF	OFF	ON	OFF

Note: DB25M to DB9F and serial cable are not included with the converter.

Manufacturer: ATEN
Model: IC485AI
Website: www.aten-usa.com/



IC485AI Module Switch Settings

Switch S1 = TxRTS / RxON

Switch S2 = DCE

Serial Setup: Check Echo Back Suppression option in the serial setup screen.

Note: DB25M to DB9F and serial cable are not included with the converter.

◆ USB Port to RS485 Converters

Manufacturer: B&B Electronics

Model: USOTL4

Website: www.bb-elec.com



USOTL4 Module Dipswitch Settings

SW1	SW2	SW3	SW4
ON	ON	ON	ON

Note: Refer to the user manual that comes with this module for windows iQpump driver installation. USB Cable is not included with the converter.

Manufacturer: Advantech

Model: ADAM-4561

Website: www.advantech.com.tw



ADAM 4561 Module Jumper Settings

Internal
JP1
1-2

Note: Refer to the user manual that comes with this module for windows iQpump driver installation. USB Cable is not included with the converter.

Manufacturer: Nudam
Model: ND-6530
Website: www.industrialpc.com



NUDAM ND-6530 Module Dipswitch Settings (located next to USB port)

SW1	SW2
ON	ON

Note: Refer to the user manual that comes with this module for windows driver installation. USB Cable is not included with the converter.

E.5 PumpScada Software

Complementary Demo Version of the PumpScada software for the iQpump Controller is available on our website at <http://iQpump.yaskawa.com>.

E.6 Energy Savings Estimation Software

Complementary Energy Savings Estimation is available on our website at <http://iQpump.yaskawa.com>.

- Note:**
1. DC link choke required on models which do not incorporate link as standard. Avoid using AC line reactors as voltage drop associated with line side inductors will reduce DC link voltage level.
 2. Manuals need to be changed by adding the following statement “When using E/F/P7U20P4 thru E/F/P7U2018 and E/F/P7U40P4 thru E/F/P7U4018 on a power supply transformer with a capacity of 600KVA or more or when using single phase input, install a DC reactor. The reactor improves the input power factor and provides protection to the rectifier circuit within the drive.”
 3. Voltage tolerance of 240/480 Vac +10/-5% applies to single phase applications. Voltage below -5% will result in additional derating. Consult factory for additional derating.
 4. Use HP column (blue) to select the drive based on applied motor HP. Amp column should not be used as the HP column is the limiting factor.

THIS PAGE INTENTIONALLY LEFT BLANK.



Appendix: F

EMC Compatibility

This section describes the measures necessary to comply with the EMC (Electro Magnetic Compatibility) Directive.

F.1 EMC Compatibility	230
F.2 Electromagnetic Compatibility (EMC)	231

F.1 EMC Compatibility

◆ Introduction

This section describes the measures necessary to comply with the EMC (Electro Magnetic Compatibility) Directive. The manual's installation and wiring instructions must be followed for compliance.

Yaskawa products are tested by authorized organizations using the standards listed below.

Product standard: EN 61800-3:1996
EN 61000-3-2; A1, A2, A14:2000

◆ Measures to Ensure Conformity of Installed Yaskawa Drives to EMC Directive

Yaskawa Drives are not required to be installed in a switch cabinet.

It is not possible to give detailed instructions for all possible types of installations, therefore this manual provides general guidelines.

All electrical equipment produces radio and line-borne interference at various frequencies. The power leads pass this on to the surrounding environment like an antenna. Connecting an item of electrical equipment (e.g. Drive) to a supply without a line filter can allow High Frequency (HF) or Low Frequency (LF) interference to penetrate the power distribution system. The basic countermeasures are isolation of the wiring of control and power components, proper grounding, and shielding of cables.

A large contact area is necessary for low-impedance grounding of HF interference. The use of grounding, straps instead of cables is therefore highly recommended.

Cable shields must be connected with ground clips.

◆ Cable Installation

Measures Against Line-Borne Interference:

Line filter and Drive must be mounted on the same metal plate. Mount the two components as close to each other as possible, with cables kept as short as possible (see [Figure F.2](#)).

Use a power cable with a well-grounded shield. Use a shielded motor cable not exceeding 82 feet (25 m) in length. Arrange all grounds to maximize the end of the lead area in contact with ground (e.g. metal plate).

Use a shielded cable with braided shield and ground the maximum possible area of the shield. It is advisable to ground the shield by connecting the cable to the ground plate with metal clips (see [Figure F.1](#)).

F.2 Electromagnetic Compatibility (EMC)

◆ Recommended EMC Filters

Table F.1 Recommended EMC Filters

Drive Model CIMR-P7U□-107	EMC Filter				
	Model Number	Current Rating	Weight lb. (kg)	Dimensions inches (mm)	NominalHp
208-240 Vac					
20P4	FS5972-10-07	10 A	2.43 (1.1)	5.500 x 13 x 1.875 (141 x 330 x 46)	0.5/0.75
20P7					1
21P5					1.5/2
22P2	FS5972-18-07	18 A	2.87 (1.3)	5.500 x 13 x 1.875 (141 x 330 x 46)	3
23P7	FS5973-35-07	35 A	3.09 (1.4)	5.500 x 13 x 1.875 (141 x 330 x 46)	5
25P5					7.5
27P5	FS5973-60-07	60 A	6.61 (3)	8 x 14 x 2.375 (206 x 355 x 60)	10
2011	FS5973-100-07	100 A	10.8 (4.9)	9.3125 x 16 x 3.125 (236 x 408 x 80)	15
2015					20
2018					25
2022	FS5973-130-35	130 A	9.48 (4.3)	3.5315 x 14.40625 x 7 (90 x 366 x 180)	30
2030					40
2037	FS5973-160-40	160 A	13.23 (6)	4.750 x 17.750 x 6.6875 (120 x 451 x 170)	50
2045	FS5973-240-37	240 A	24.25 (11)	5.125 x 24 x 9.4375 (130 x 610 x 240)	60
2055					75
480 Vac					
40P4	FS5972-10-07	10 A	2.43 (1.1)	5.500 x 13 x 1.875 (141 x 330 x 46)	0.5/0.75
40P7					1
41P5					1.5/2
42P2	FS5972-18-07	18 A	2.87 (1.3)	5.50 x 13 x 1.875 (141 x 330 x 46)	3
43P7					5
45P5					7.5
47P5					10
49P0/4011					FS5972-35-07
4015	FS5972-60-07	60 A	8.82 (4)	9.250 x 16 x 2.50 (236 x 408 x 65)	25
4018					30
4024/4030	FS5972-70-52	70 A	7.5 (3.4)	3 x 13 x 7.250 (80 x 329 x 185)	40/50
4037	FS5972-130-35	130 A	10.36 (4.7)	3.5 x 14.375 x 7 (90 x 366 x 180)	60
4045					75
4055					100
4075	FS5972-170-40	170 A	13.23 (6)	4.750 x 17.750 x 6.6675 (120 x 451 x 170)	125
4090	FS5972-250-37	250 A	24.25 (11)	5.125 x 24 x 9.4375 (130 x 610 x 240)	150
4110					200

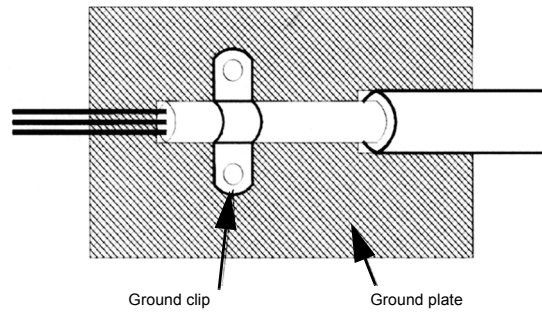

Figure F.1 Grounding Surface Layout

The grounding surfaces must be highly conductive bare metal. Remove any varnish or paint from grounding surfaces.

- Ground the cable shields at both ends.
- Ground the motor of the machine/application.

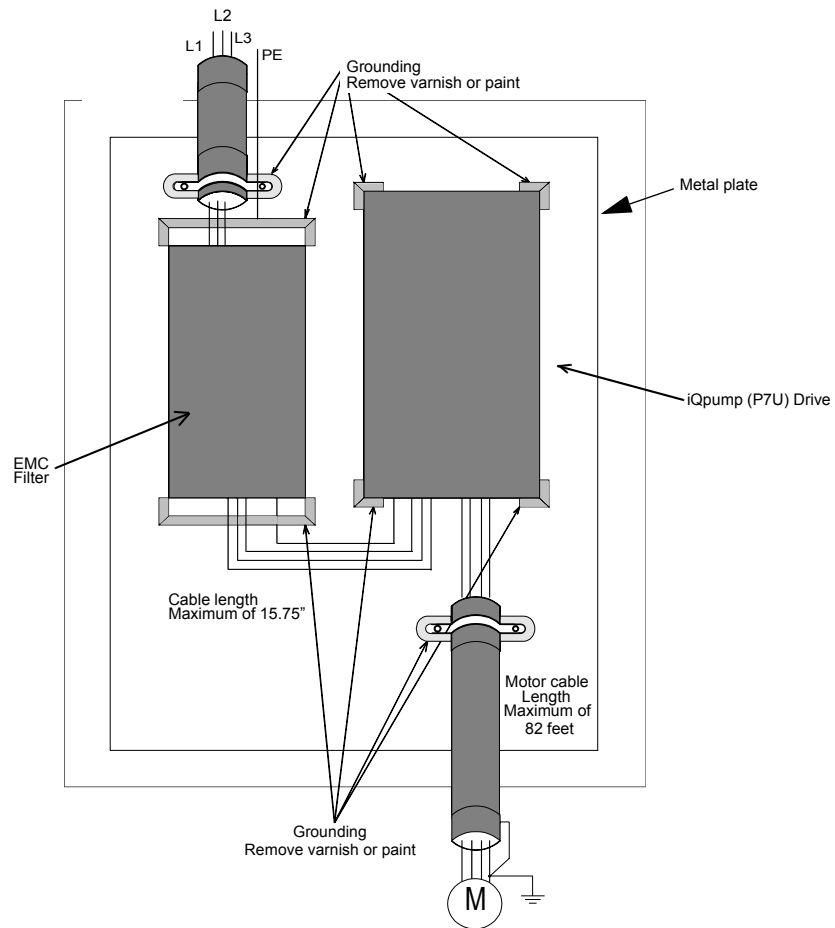

Figure F.2 EMC Filter Layout

Page intentionally blank

iQpump Drive



YASKAWA ELECTRIC AMERICA, INC.

Drives Division

16555 W. Ryerson Rd., New Berlin, WI 53151, U.S.A.

Phone: (800) YASKAWA (800-927-5292) Fax: (847) 785-2730

Internet: <http://www.yaskawa.com>

YASKAWA ELECTRIC AMERICA, INC.

Chicago-Corporate Headquarters

2121 Norman Drive South, Waukegan, IL 60085, U.S.A.

Phone: (800) YASKAWA (800-927-5292) Fax: (847) 887-7310

Internet: <http://www.yaskawa.com>

